

The background of the cover is a detailed technical line drawing of a motorcycle's engine and chassis, rendered in a light grey color against a dark blue-grey background. The drawing shows various components like the cylinder head, pistons, valves, and the frame, providing a mechanical context for the service manual.

ROYAL ENFIELD SERVICE MANUAL

LS410

This page is intentionally left blank

TABLE OF CONTENTS

GENERAL INFORMATION	1
TECHNICAL SPECIFICATION	2
MAINTENANCE	3
GENERAL AND SPECIAL TOOLS	4
ENGINE	5
CHASSIS	6
FUEL SYSTEM.....	7
EVAPORATIVE EMISSION CONTROL SYSTEM (EVAP)	8
BRAKES AND ABS.....	9
ENGINE MANAGEMENT SYSTEM (EMS).....	10
ELECTRICAL SYSTEM	11
EURO V ADDON CONTENT.....	12

CONTENTS	PAGE
1. General Information	11
1.1 About this Manual	11
1.2 How to Use this Manual	12
1.3 Important Information	13
1.4 General Precautions	13
1.5 Prior to Service	14
2. Technical Specifications	24
2.1 Engine	23
2.2 Ignition System	23
2.3 Transmission	23
2.4 Chassis	24
2.5 Electrical System	24
2.6 Dimensions	25
2.7 Weights	25
3. Periodical Maintenance Schedule (PMS)	26
4. General and Special Tools	32
4.1 General Tools	33
4.2 Measurement Tools	36
4.3 Special Tools	38
5. Engine	51
5.1 Engine Removal from Main Frame	47
5.2 Engine Dismantling	64
5.3 Engine Assembly	97
5.4 Engine Assembly to Frame	129
5.5 Engine Inspection	145

CONTENTS	PAGE
6. Chassis	154
6.1 Air Filter Box	156
6.2 Control Cables	162
6.3 Handlebar	177
6.4 Exhaust Pipe, silencer.....	187
6.5 Footrests, Stands and Saree Guard Footrest	193
6.6 Mudguards/Number Plates/Grab Handle.....	200
6.7 Side Panels and Rider Seat	207
6.8 Wheels	213
6.9 Suspension	238
6.10 Subframe.....	267
6.11. Troubleshooting	275
7. Fuel System.....	287
7.1. Fuel System Components.....	289
8. Evaporative (EVAP) Emission Control System	298
8.1. Evaporative (EVAP) Emission Control System	298
9. Brakes and ABS.....	305
9.1. Brake - Front	308
9.2. Brake - Rear	312
9.3 Anti-lock Braking System (ABS).....	330
9.4. Preparation (Front Disc Brake)	347
9.5. Reassembly.....	349
9.6. Preparation (Rear Disc Brake).....	350
9.7. Reassembly	351
9.8. Brake Bleeding	353

CONTENTS	PAGE
10. Engine Management System (EMS)	361
10.1 Engine Management System (EMS)	363
11. Electrical System.....	388
11.1 Headlamp and Cluster Dismantling	391
11.2 Connectors behind Headlamp Housing.....	392
11.3 Tail Lamp Dismantling.....	395
11.4 Brake Lamp Connectors Dismantling	396
11.5 Trafficators Dismantling	396
11.6 Battery Dismantling.....	397
11.9 Battery Assembly.....	400
11.10 Trafficators Assembly.....	401
11.11 Brake Lamp Connectors Assembly.....	403
11.12 Tail Lamp Assembly.....	403

GENERAL INFORMATION

CONTENTS	PAGE
1.1 About this Manual	11
1.2 How to Use this Manual.....	12
1.3 Important Information	13
1.4 General Precautions.....	13
1.5 Prior to Service	14

1. General Information

1.1 About this Manual

This service manual has been created primarily for use by a technically competent and trained service personnel to

- Get familiarized and understand the construction of various aggregates of motorcycles.
- Assist in carrying out the correct and factory-approved service and overhauling procedures of the motorcycles.

While it is not possible to comprehensively capture all the service practices in this manual, it is expected that the technically competent person would have a basic knowledge and understanding of carrying out systematic service and overhauling procedures.

We strongly recommend that personnel without basic understanding of repair techniques and procedures DO NOT attempt to service or overhaul any part of the motorcycle using this manual, as it might result in wrong diagnosis and repair and ultimately render the motorcycle unsafe for use and result in expensive repair costs for the customer.

We also STRONGLY recommend that any technician who wishes to service Royal Enfield motorcycles, undergo systematic technical trainings at our Royal Enfield training academies, where the correct servicing and overhauling procedures are imparted by experienced and competent trainers, providing hands on practical sessions.

Lastly, we would recommend and insist that the periodic maintenance and overhauling of the Royal Enfield motorcycles be carried out ONLY through authorized Royal Enfield service stations where factory trained and experienced service technicians are always available.

1.2 How to Use this Manual

This service manual is divided into several chapters as detailed below. This will help the technical personnel to easily refer to the particular section of interest, for carrying out the correct maintenance and repair procedure as recommended by Royal Enfield. **Click and explore on the blue icons to refer individual chapters.**

Chapter No.	Chapters
1	General Information
2	Technical Specifications
3	Periodic Maintenance Schedule
4	General Tools and Special Tools
5	Engine
6	Chassis
7	Fuel System
8	EVAP (Evaporative Emission Control System)
9	Brakes and ABS (Anti-Lock Braking System)
10	EMS (Engine Management System)
11	Electrical System
12	Index and Glossary

There are elaborate details of CAUTIONS, WARNINGS provided in this service manual in each of the individual chapters to highlight details of information and/or precautions that need to be taken while servicing the motorcycle aggregates.

1.3 Important Information

To enhance customer satisfaction and to improve the performance of the motorcycle, Royal Enfield will carrying out modifications and changes in the motorcycles in the years to come. Such changes will be intimated periodically and continuously through service bulletins and notifications to the authorized Royal Enfield dealers and service stations and will also be included in the future editions of this service manual.

1.4 General Precautions

Important information and points that need special focus and attention while servicing the motorcycles are highlighted in this service manual as follows:

NOTE	<i>Indicates points of particular interest for more efficient and convenient operation.</i>
WARNING	Indicates points of particular interest for more efficient and convenient operation.
CAUTION	Alerts the technician about potential personal injury hazards.

WARNING

Stop the engine when servicing the fuel system. Do not smoke or allow any open flame or sparks near gasoline. Gasoline is extremely flammable and highly explosive, which could result in serious injury or fatal accidents.

Do not use after-market parts which can adversely affect the performance. Removing or altering factory-installed parts can adversely affect performance and could result in serious injury or fatal accidents.

CAUTION

Do not tamper or attempt any modifications to any part of the engine management, fuel injection, ABS brakes, exhaust and evaporative emission systems of the motorcycle as it is against the law and will render the motorcycle unfit and illegal for road use.

1.5 Prior to Service

Proper preparation is very important before commencing any maintenance or repair on a motorcycle. This will not only result in an efficient and accurate repair job but will also save time and result in "FIRST TIME RIGHT" and help the customer gain confidence in the technician's capability.

The following points are essential for carrying out maintenance or repairs on a motorcycle correctly:

- 1. Understand and record customer concerns accurately.**
- 2. Test-ride the motorcycle wherever required to understand the customer concerns accurately.**
- 3. Refer to the past history of maintenance and repairs carried out on the motorcycle.**
- 4. Water-wash and clean the motorcycle.**
- 5. Maintain the work area - cleanliness, lighting, ventilation, etc.**
- 6. Store appropriate general purpose and special tools for carrying out the maintenance.**
- 7. Perform systematic dismantling and reassembly of the aggregates in the motorcycle.**
- 8. Store required spares and consumables for the maintenance.**
- 9. Perform correct inspection and diagnosis of the motorcycle.**
- 10. Test-ride after repairs to ensure that motorcycle is performing correctly.**
- 11. Explain the repairs and maintenance carried out to the customer.**
- 12. Encourage customer to take a test-ride so as to gain confidence that the repairs have been carried out correctly and to his satisfaction.**

1.5.1. Customer Complaints

Discuss with customer to clearly understand their concerns and issues on the motorcycle. Create a job card detailing all the complaints mentioned.

1.5.2. Test-Ride

Do a test ride wherever required to reconfirm issues mentioned by customer. This will also help to identify other issues if any.

1.5.3. Service Records

Check the service records.

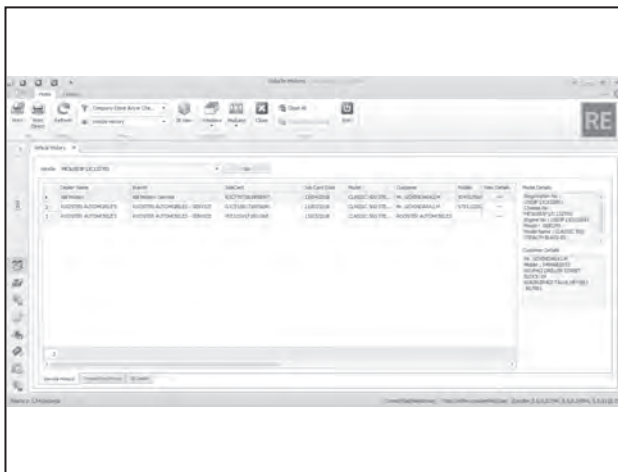

1.5.4. Clean Work Area

Ensure the work space is clean and adequately ventilated fresh air.

1.5.5. Cleaning

Cleaning before Dismantling and Inspection

Water-wash and clean the motorcycle for a thorough inspection to uncover any visual damages such as breakages, leaks, misalignments, etc., and to clearly understand the issues raised by the customer.

Clean the motorcycle thoroughly before disassembly to avoid dirt or other foreign materials entering into sealed areas as it can cause excessive wear and damage to the parts.

1.5.6. General and Special Tools

All general and special tools required for servicing are listed in the respective section of this service manual. Ensure that you have all the required tools for servicing. Place tools handy before beginning the service or maintenance.

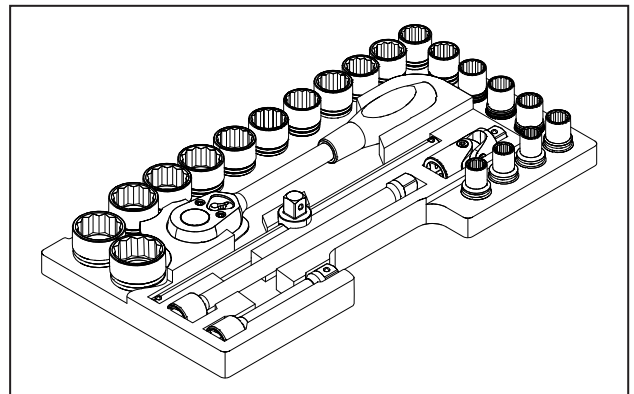

Special Tools

A list of special tools required for the dismantling and assembling of parts has been provided in each section.

Ensure that only Royal Enfield recommended special tools are used wherever mentioned. Dismantling or assembling without the use of special tools may cause severe, irreparable damage to parts.

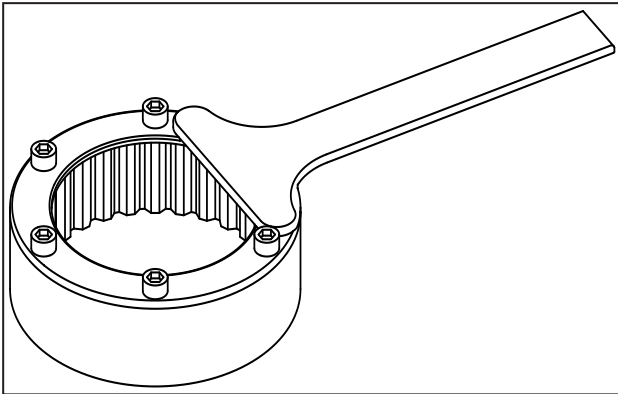

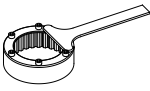
 SPL	Part No: ST30266/a
	Part Name: Clutch holder

Storing Tools

After completing the job, ensure that all tools are cleaned and kept back in their designated place, so that they do not rust and can be easily found the next time.

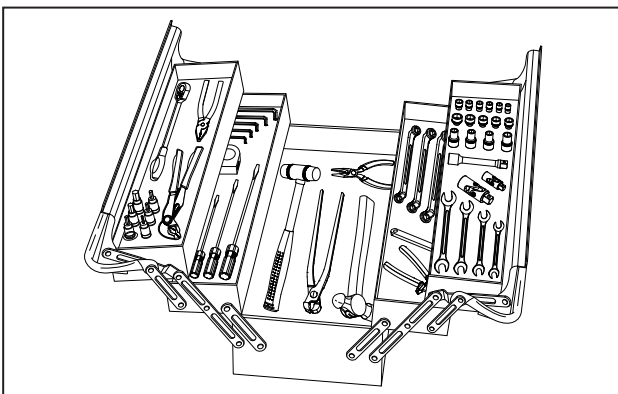

Tool Usage and Safety

Use eye protection equipment when performing any task using air-operated tools.

Pneumatic tools should be used only for removal, and not for tightening.

Ratchets and Extension

Use an extension on a ratchet's handle or power handle at suitable places.

Torque wrenches should always be used only for tightening fasteners to their recommended torque.

Once you hear the click sound, stop tightening and remove the torque wrench from the fastener. Do not tighten further as it will cause damage to torque wrench and fastener.

Hammers and Mallets

Use eye protection equipment and gloves while using a hammer.

Use a hammer or mallet that is suitable for the job.

Use only a plastic mallet to remove or assemble delicate parts like Oil seals/dowels/bushes, especially in the engine. DO NOT use a metal hammer as it will cause damage to the parts.

Screwdrivers

Use the right type and size of screwdriver at the right places.

Do not use a screwdriver for punching, chiseling or scraping, or as a lever to lift another object.

Use Ramp

Royal Enfield recommends the use of a suitable ramp to hold the motorcycle vertically in a convenient position for easy repairs.

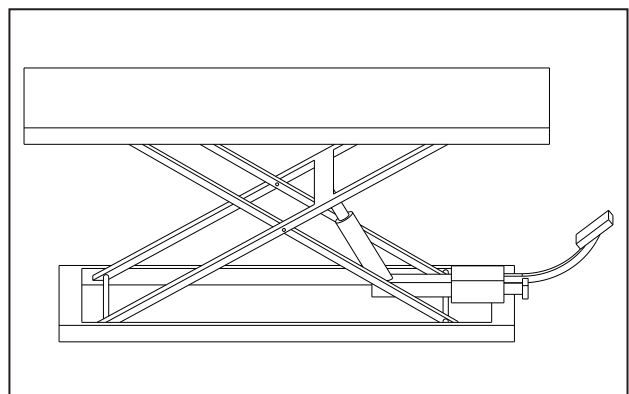

1.5.7. Prior to Disassembly

Always ensure ignition switch and stop switch are in OFF position before dismantling any aggregate on the motorcycle.

Always drain engine oil (in warm condition) whenever servicing any part of the engine/oil cooler.

Always drain fuel from the fuel tank whenever it is removed from the frame.

Always disconnect battery terminals whenever servicing the engine management system, ABS and/or any electrical wiring.

1.5.8. Disassembly/Assembly Sequence

Follow the disassembling and assembling sequence as given in the respective sections of this manual. In most cases assembly order is the reverse of disassembly. However, please follow the sequence provided in this service manual. If correct sequence is not followed, parts can be damaged.

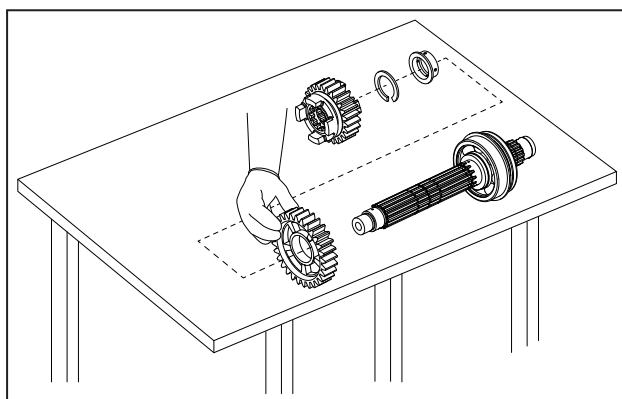

Removal of Bearings and Seals and fitting them in place

While removing bearings and seals, use correct tools mentioned in the relevant sections. Do not use excess force as it may damage parts. Similarly, while pressing bearings and seals in place lubricate them, use correct tools and visually examine if they are fitted in proper place. Bearings or seals should not be loose in the casing. Use of wrong tools, too much hammering or application of extra force may lead to damage of the bearings and seals.

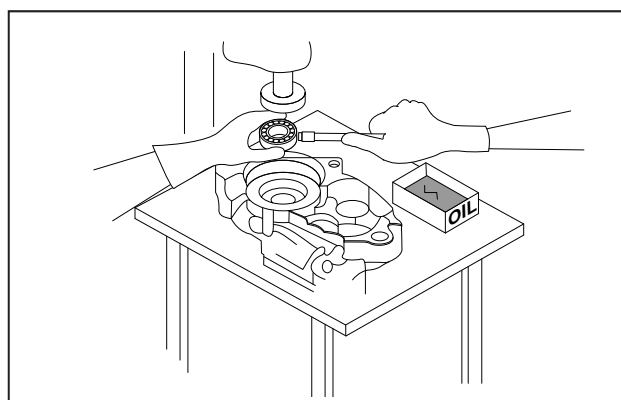

Lubrication

During assembly, ensure that all rotating and/or sliding parts are lubricated to minimize wear and tear during initial operation. Use Royal Enfield recommended oil and lubricants only. All brake system parts should be cleaned and lubricated with recommended brake fluid only (e.g., piston, MC, etc.).

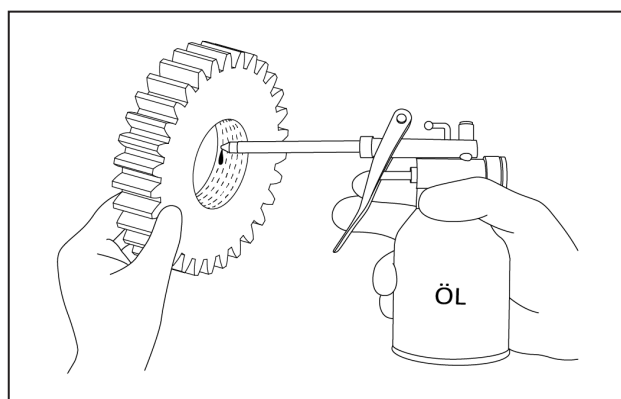

Tightening Sequence and Torque

The correct tightening sequence and torque has been provided in various sections of this service manual. Incorrect sequence or wrong torque will cause serious damage to parts.

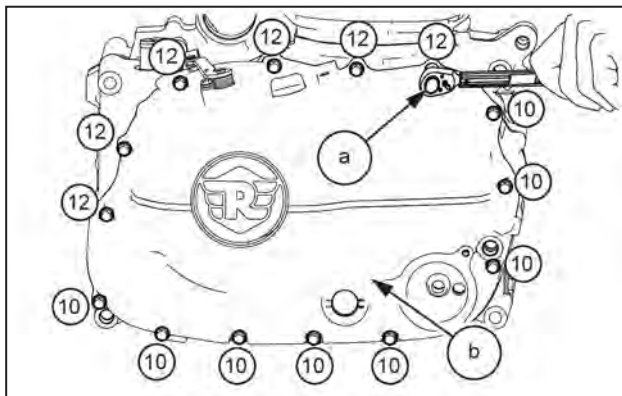

Battery Disconnection and Connection

When required, disconnect the battery cables from the battery. Disconnect the ground negative (-) terminal first and then positive (+) terminal to avoid short circuit. While connecting, first connect the positive (+) and then the negative (-) terminals.

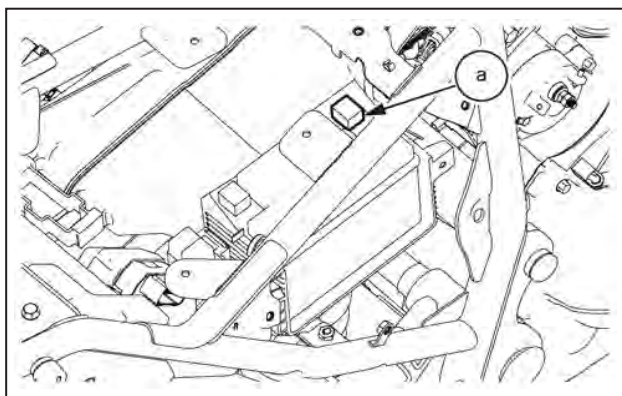

Electrical Connectors

Ensure that lock is released in the connectors before disconnecting or connecting electrical connectors. Excessive force to pull out connectors without releasing the lock may damage the connector.

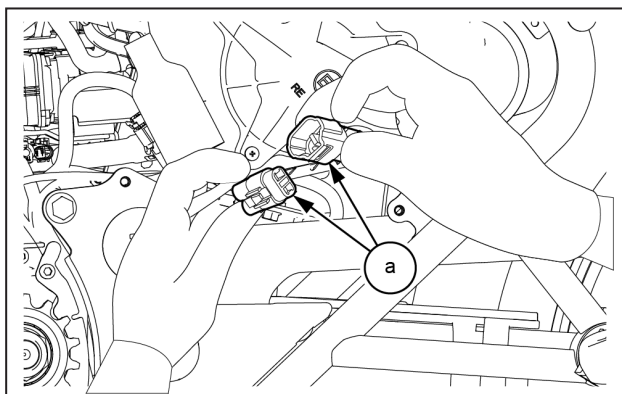

1.5.9. Safety

Handling Fragile Parts

Be careful while handling fragile parts like headlamp, indicator, bulb, etc. Use proper tools and do not apply undue force. After removing, store the parts in a safe place.

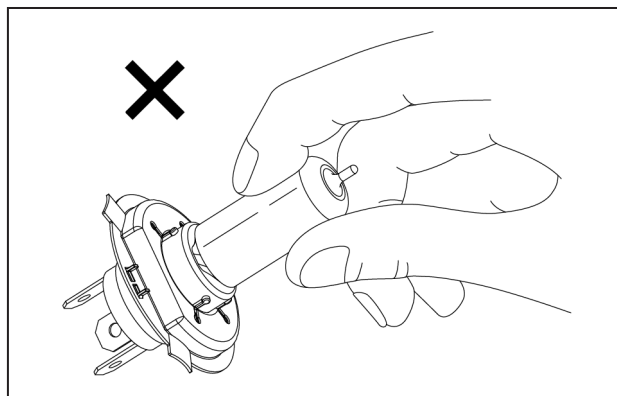

Welding

Royal Enfield does not recommend welding on the frame or any other parts of the motorcycle. Welding will make the frame weak and can also affect the balance of the motorcycle.

In motorcycles equipped with electronic control modules like EMS and ABS, welding will cause irreparable damage to the EMS/ABS system.

This will also void motorcycle warranty.

Tampering

It is illegal to tamper with the following:

- Exhaust system
- Fuel systems
- Engine Number and/or VIN Information Plate
- Wiring harness
- Frame

This will lead to NON CONFORMANCE to the noise and emission regulations in force, causing serious performance issues besides irreparable damage to the motorcycle.

This will also void warranty of the motorcycle.

1.5.10. Storage of Removed Parts

After disassembly of all parts including sub-assemblies, clean and store them in a separate storage bin to prevent from dust and place the parts near the working area.

Protective Covers

Use proper covers on the motorcycle to avoid scratching/damaging paint during service.

1.5.11. Inspection

Reuse of worn or damaged parts may lead to serious malfunction and/or unsafe operation of the motorcycle. All removed parts should be cleaned and visually inspected for wear-out, corrosion, discoloration, damage, etc. Refer to the appropriate sections of this manual for service limits on individual parts. If any wear or tear has been found or if the part is beyond its service limit, replace the parts with Royal Enfield Genuine parts.

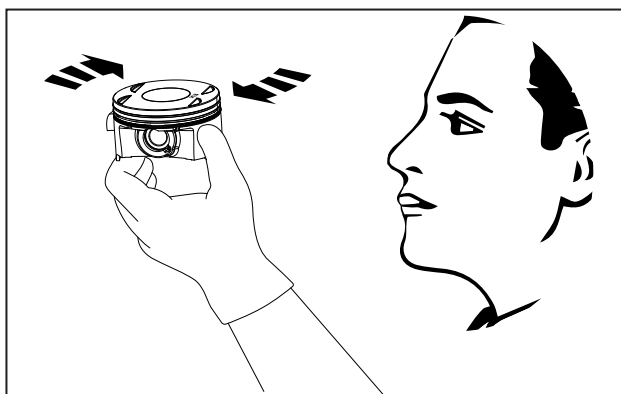

1.5.12. General

One-time Parts/Consumables

In the service manual, we have listed parts that are for one-time use only. Replace and do not reuse parts such as:

- a) Oil seals
- b) Filters
- c) Gaskets
- d) Rubber washers

- e) Cylinder head bolts
- f) Connecting rod bolts
- g) Crankcase bolts
- h) O - Rings

Spares/Lubricants/Consumables

Ensure that you have all the spares/lubricants/consumables required for the servicing of a particular section stored near you for easy access. Use only Royal Enfield Genuine parts.



Rust or Corrosion Removal

In case a rusted or corroded part cannot be removed, apply recommended/reputed rust removal agents, wait for the removal agent to free up the rust/corrosion and then remove the part. Clean and inspect the part carefully to confirm it can be reused.

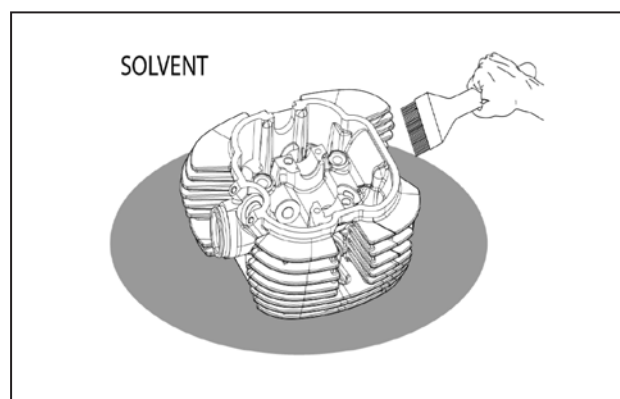

Hazardous Substances

Many liquids and other substances like fuel, lubricants, brake oil, adhesives, etc., used in automobiles are poisonous. Keep the fluids out of reach of children. Do not bring in contact with eyes and skin. Wash exposed skin thoroughly with soap and water. If any irritation persists, consult a doctor immediately.

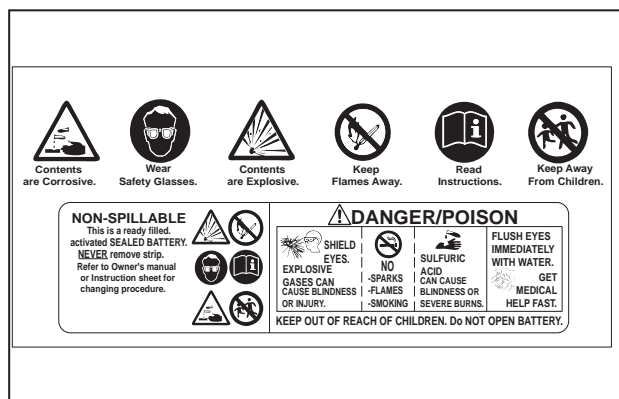

Environmental Protection

Dispose used oil and other consumables like gaskets, O-rings, oil filters through authorized waste-disposal agencies.

Do not spill brake oil on painted parts. It will damage the paint.

Do not use mineral-based grease in brake parts as it will damage the hydraulic seals.

Gasoline/Petrol

Gasoline/Petrol is highly flammable. Be careful while removing the fuel tank and handling Gasoline/Petrol. Store it in a safe place and ensure it is stored in a well ventilated area, away from the work area and fire.

After-market Parts and Accessories

Royal Enfield strongly recommends use of Royal Enfield genuine parts and accessories only.

A list of all accessories available from Royal Enfield can be obtained from Royal Enfield dealers.

Yet, if you are using any after-market part that is not supplied by Royal Enfield, do ensure that it does not interfere with the functioning of any of the motorcycle parts.

Final Inspection

Once the repairs/servicing is done, check and confirm that all tasks mentioned on the job card have been performed. Do a proper testing to ensure that all critical functions are working properly, all reported issues have been resolved and no new problem has been introduced.

Follow the final inspection checklist and sign out through the final inspector.

1.5.13. Delivery to the Customer

Ensure that the customer is informed about all the repairs that have been carried out. Also let he/she know about the parts that have been replaced and consumed during the repairs. Demonstrate to the customer that all his/her reported issues have been resolved. Insist on a test ride if required.

Please preserve the parts. Show it to the customer and dispose it with the customer's permission.

TECHNICAL SPECIFICATIONS

CONTENTS	PAGE
2. Technical Specifications	23
2.1 Engine	23
2.2 Ignition System	23
2.3 Transmission	23
2.4 Chassis	24
2.5 Electrical System	24
2.6 Dimensions.....	25
2.7 Weights	25

1. Technical Specifications

1.1 Engine	
Engine Type	Single Cylinder, 4 Stroke, SOHC, Air cooled with Oil cooler, Fuel Injection
Bore	78 mm
Stroke	86 mm
Swept Volume	410.94cc
Compression Ratio	9.5:1
Max Power	24.3 bhp (17.88 kw) @ 6500 RPM
Max Torque	32 N m @ 4250 ± 250 RPM
Idle RPM	1250 ± 50 RPM
Starting	Electric Start
Air Filter Element	Paper element
Lubrication	Forced lubrication, Wet sump
Gear Box	5 Speed Constant Mesh
Engine Oil Tank Capacity	2.3 L (Initial fill only), 2.0 L (Subsequent Refills)
Engine oil grade	SAE 15W 50 API SL Grade JASO MA 2
Cooling	Air cooled with Oil cooler

1.2 Ignition System	
Ignition	Electronic ECU / Variable
Spark Plug	BOSCH UR5CC
Spark Plug Gap	0.7 mm to 0.8 mm

1.3 Transmission	
Clutch	Wet multiplate
Primary Drive	Gear
Primary Ratio	2.312:1
Gear Box	5 Speed Constant Mesh
Gear Ratio	2.916:1 1.833:1 1.428:1 1.173:1 1:000:1
Secondary Drive	5/8" Chain & Sprocket
Secondary Ratio	2.533:1
Drive Chain links	110 links

1.4 Chassis

Frame	Half duplex split cradle		
Suspension	Front	Telescopic, Hydraulic Damping, Front wheel travel: 200 mm	
	Rear	Swing arm with Linkage type Hydraulic damping Mono shock, Rear wheel travel: 180 mm	
Hydraulic Disc Brakes	Front	300mm Dia disc.	
	Rear	240mm Dia disc.	
Tyre size	Front	90 / 90 - 21	
	Rear	120 / 90 - 17	
Tyre Pressure		Solo	With Pillion
	Front	25 PSI / 1.75 Kg/cm²	27 PSI / 1.89 Kg/cm²
	Rear	32 PSI / 2.25 Kg/cm²	34 PSI / 2.39 Kg/cm²
Steering Lock	Integrated with Ignition Lock		
Fuel tank capacity*	15 + 0.5 litres approx *		
Low fuel warning	Fuel Gauge (Red zone) 5.5 +0.5 lts.		
Dead stock (unusable fuel)	0.5 litre approx.		
The above values are approximate and the actual fuel filling capacity will vary from the values mentioned.			

1.5 Electrical System

Flywheel magneto	221W @ 1500 rpm
Generation	Alternator, III Phase
System	12V - DC
Battery	12V - 8 AH MF
Head lamp	12V, H4-60/55W - BULB
Tail lamp / Brake lamp	12V- 4/1W LED
Licence Plate illuminator	12V- LED
Front position lamp	12V - LED
Speedometer lamp	12V - LED
Hi beam indicator	12V - LED
Neutral lamp telltale	12V - LED
Turn signal telltale	12V - LED
Turn signal	12V, 10W * 4 Nos.
Horn	12V, 2.5 Amp.
Starter Motor	12V, 0.7 KW
Instrument Cluster	Digital cluster with main and compass LCD
Side Stand indicator	LCD Indication

⚠ WARNING

Using bulbs/other electrical gadgets other than specified rating may lead to over loading/erratic behavior/premature failure of electrical system. Modifications on the motorcycle which are not approved by Royal Enfield may not only disqualify for warranty, but will also affects the performance of the motorcycle.

1.6 Dimensions	
Length	2190 mm
Width	840 mm
Height	1360 mm
Wheel base	1465 mm
Ground clearance.	220 mm
Saddle Height	800 mm

1.7 Weights	
Kerb weight (90% fuel&oil)	191 kgs.
Max. pay load (Inclusive of rider mass)	174 Kgs.

- Values/Dimensions given above are for your guidance only.
- In view of continuous improvements being done on our motorcycles, the specifications are subject to change without prior notice.

Periodic Maintenance Schedule

PERIODIC MAINTENANCE SCHEDULE (PMS)

1. Periodical Maintenance Schedule (PMS) (For EURO IV Model)

The maintenance schedule detailed here will help you maintain your Himalayan motorcycle meticulously and to get a long trouble free service. The schedule provided herein is based upon average 400CC riding conditions and indicates at which regular inspections, adjustments, replacements and lubrications frequency are to be carried out. The frequency of the maintenance must be shortened depending upon the severity of the driving condition or if the motorcycle is used in a very dusty environment. Contact the nearest Royal Enfield Authorized Dealer/Service Center for expert advice and to carry out the required maintenance.

Sl. No.	Description	Periodic Maintenance										
		0.5	5	10	15	20	25	30	35	40	45	50
	km (x 1000)	0.3	3	6	9	12	15	18	21	25	28	31
	Miles (x 1000)	1.5	6	12	18	24	30	36	42	48	54	60
	Months											
1	Engine oil (Level check / Replace)(#)	R	I	R	I	R	I	R	I	R	I	R
		Check level at every 1000 Kms or earlier as required										
2	Engine oil filter element (#)	R		R		R		R		R		R
3	Engine oil strainer on crankcase LH (#)	I&A	I&A	I&A	I&A	I&A	I&A	I&A	I&A	I&A	I&A	I&A
4	Inlet / Exhaust Tappet setting	I&A	I&A	I&A	I&A	I&A	I&A	I&A	I&A	I&A	I&A	I&A
5	Rubber hose, Inlet manifold Adapter	I	I	I	I	I	I	I	I	R	I	I
6	Oil cooler inlet & outlet pipes *	I	I	I	I	I	I	I	I	I	I	I
7	Spark plug	C&A	C&A	C&A	C&A	C&A	C&A	C&A	C&A	C&A	C&A	C&A
8	HT leads for crack	I	I	I	I	I	I	I	I	I	I	I
9	Fuel Hose & Clip	I	I	I	I	I	I	I	I	I	I	I
10	Fuel Pump (under tank) Mounting	Check for screw tightness in all services										
11	Air filter element	C	C	R	C	R	C	R	C	R	C	R
		Clean/ Replace more frequently if motorcycle always used in dusty / off Road conditions										
12	Accelerator Cable	I&A	I&A	I&A	I&A	I/A/R	I/A/R	I/A/R	I/A/R	I/A/R	I/A/R	I/A/R
13	Rubber Hose, Air filter to Throttle body	I	I	I	I	I	I	I	I	R	I	I
14	PAV pipes & Hose clip	I	I	I	I	I	I	I	I	R	I	I
15	Evaporative Emission Equipment rubber hoses	I	I	I	I	I	I	I	I	R	I	I

I - Inspect (Clean and lubricate if necessary) A - Adjust(If Necessary) L - Lubricate R - Replace C - Clean
T- Re-tighten
(#) - After First service, Engine oil and Engine oil filter replacement is a mandatory at every 12 months even the vehicle has not covered the specified kms.

16	Throttle body- Cleaning spray	Throttle body should be removed from the vehicle and cleaned with a dry Microfiber cloth. Usage of throttle body cleaners or any similar solvent or alcohol based liquids for cleaning is strictly prohibited. Throttle body cleaning every 10000 kms / 12 Months or earlier as required.											
17	Clutch Cable	I&A	I&A	I&A	I&A	I&A	I&A	I&A	I&A	I&A	I&A	I&A	
18	Clutch free play	Adjust every 1000 Kms or earlier as required											
19	Clutch no slippage	I	I	I	I	I	I	I	I	I	I	I	
20	Steering head bearings #	I&A	Inspect,adjust & lubricate for every 5000 km or earlier as required. Replace if necessary										
21	Front Fork oil / leak	I	I	I	I	R	I	I	I	R	I	I	
22	Rear Wheel Drive Chain (#)	I&A	Clean, Lubricate & Adjust every 1000 Kms or earlier as required										
23	Battery terminals (apply petroleum jelly)	C	C	C	C	C	C	C	C	C	C	C	
24	Earth wire eyelet Tightness			I		I		I		I		I	
25	Hydraulic Brake Fluid - Front & Rear (#)	I	I	I	I	R	I	I	I	R	I	I	
26	Hydraulic brake hose & Washers - Front & Rear (#)	I	I	I	I	I	I	I	I	I	I	I	
27	Brake Pads - Front & Rear (#)	I	I	I	I	I	I	I	I	I	I	I	
28	Tyre wear pattern (Front & Rear) (#)	I	I	I	I	I	I	I	I	I	I	I	
29	Spokes tightness / Wheel rim run out front & rear (#)	I	I	I	I	I	I	I	I	I	I	I	
30	Front & Rear wheel bearings for play (#)	I	I	I	I	I	I&R	I	I	I	I	I&R	
31	Swingarm Pivot Bearings (#)	I	Inspect & If required lubricate for every 5000 km or earlier as required. Replace if necessary										
32	Rear Suspension Linkages (#)	I	Inspect & If required lubricate for every 5000 km or earlier as required. Replace if necessary										
33	Rear Brake Pedal Pivot	L	L	L	L	L	L	L	L	L	L	L	
34	Rear Brake Pedal free play	Adjust every 1000 Kms or earlier as required											
35	Rear wheel cush rubbers (#)	I	I	I	I	I&R	I&R	I&R	I&R	I&R	I&R	I&R	
36	All Mounting Fasteners in vehicle for tightness (#)	I&T	I&T	I&T	I&T	I&T	I&T	I&T	I&T	I&T	I&T	I&T	
37	Hand levers, Centre stand, side stand, Rider & Pillion foot rest Pivots & Gear shift Levers (#)	Lubricate every 1000 Kms or earlier as required											
38	Cam Chain / Chain Pads / Auto chain Tensioner	I	I	I	I	I	I	I	I	I	I	I&R	
39	Starter motor & Starter relay connections	I	I	I	I	I	I	I	I	I	I	I	
40	Side stand switch operation	I	I	I	I	I	I	I	I	I	I	I	
I - Inspect (Clean and lubricate if necessary) A - Adjust (If Necessary) L - Lubricate R - Replace C - Clean T - Re-tighten (#) - After First service, Engine oil and Engine oil filter replacement is a mandatory at every 12 months even the vehicle has not covered the specified kms.													

NOTE

- For Maintenance after 50,000 kms, Please repeat the same frequency specified above, in consultation with a Royal Enfield Authorized Dealer/Service Center.

2. Periodical Maintenance Schedule (PMS) (For EURO V Models)

The maintenance schedule detailed here will help you maintain your Himalayan motorcycle meticulously and to get a long trouble free service. The schedule provided herein is based upon average 400CC riding conditions and indicates at which regular inspections, adjustments, replacements and lubrications frequency are to be carried out. The frequency of the maintenance must be shortened depending upon the severity of the driving condition or if the motorcycle is used in a very dusty environment. Contact the nearest Royal Enfield Authorized Dealer/Service Center for expert advice and to carry out the required maintenance.

Sl. No.	Description	Periodic Maintenance											
		0.5	5	10	15	20	25	30	35	40	45	50	
	km (x 1000)	0.5	5	10	15	20	25	30	35	40	45	50	
	Miles (x 1000)	0.3	3	6	9	12	15	18	21	25	28	31	
	Months	1.5	6	12	18	24	30	36	42	48	54	60	
1	Engine oil (Level check / Replace)(#)	R	I	R	I	R	I	R	I	R	I	R	
		Check level at every 1000 Kms or earlier as required											
2	Engine oil filter element (#)	R		R		R		R		R		R	
3	Engine oil strainer on crankcase LH (#)	C	C	C	C	C	C	C	C	C	C	C	
4	Inlet / Exhaust Tappet setting	I&A	I&A	I&A	I&A	I&A	I&A	I&A	I&A	I&A	I&A	I&A	
5	Rubber hose-Intake adapter	I	I	I	I	I	I	I	I	I	I	I	
6	Evaporative emission equipment rubber hoses & drain the over filled by removing plug	I	I	I	I	I	I	I	I	R	I	I	
7	Spark plug			C&A		R		C&A		R		C&A	
8	HT leads for crack	I	I	I	I	I	I	I	I	I	I	I	
9	Air filter element	C	C	R	C	R	C	R	C	R	C	R	
		Clean/ Replace more frequently if operated in dusty condition											
10	Vent pipe under air filter box	I	I	I	I	I	I	I	I	I	I	I	
11	Starter motor & starter relay connections	I	I	I	I	I	I	I	I	I	I	I	
12	Battery terminals (apply petroleum jelly)	C	C	C	C	C	C	C	C	C	C	C	
13	Earth wire eyelet contact											I	
I - Inspect (Clean and lubricate if necessary) A - Adjust(If Necessary) L - Lubricate R - Replace C - Clean T- Re-tighten (#) - After First service, Engine oil and Engine oil filter replacement is a mandatory at every 12 months even the vehicle has not covered the specified kms.													

Sl. No.	Description	Periodic Maintenance										
		0.5	5	10	15	20	25	30	35	40	45	50
	km (x 1000)	0.3	3	6	9	12	15	18	21	24	27	30
	Miles (x 1000)	1.5	6	12	18	24	30	36	42	48	54	60
	Months (EURO IV & EURO V)											
14	Injector hose	I	I	I	I	I	I	I	I	I	I	I
15	Fuel filter in fuel pump							R				
16	Front fork oil		III		I	R	I	I	I	R	I	I
17	Steering ball races play	I	I	I	I	I	I	I	I	I	I	I
18	Wheel rim run out front & rear	I		I		I		I		I		I
19	Swing arm pivot bush & spacer	I	Inspect & If required lubricate for every 5000 km or earlier as required. Replace if necessary									
20	Tyre wear pattern (front & rear)	I	I	I	I	I	I	I	I	I	I	I
21	Rear wheel drive chain	Clean, lubricate every 1000 Kms / clean, lubricate & adjust every 5000 kms. or earlier as required										
22	Rear wheel cush drive rubbers					I&R				I&R		
23	Front & rear brake house & banjo bolt	I	I	I	I	I	I	I	I	I	I	I
24	Brake fluid level, front & rear disc	I	I	I	I	R	I	I	I	R	I	I
25	Clutch level /cable free play	Adjust every 1000 Kms or earlier as required & replace if required										
26	Hand levers & foot levers	Lubricate every 1000 Kms or earlier as required										
27	Pivot-side stand, center stand, pillion foot rest, gear shifter, brake pedal, levers	L	L	L	L	L	L	L	L	L	L	L
28	Throttle cable	Adjust every 5000 Kms or earlier if required										
29	Brake pads - front & rear	I	I	I	I	I	I	I	I	I	I	I
30	Side stand switch operation	I	I	I	I	I	I	I	I	I	I	I
31	All mounting fastners in vehicle for tightness	I	I	I	I	I	I	I	I	I	I	I
32	Throttle body - ceaning	Throttle body should be removed from the vehicle and cleaned with a dry microfiber cloth, usage of throttle body cleaners or any similar solvent or alcohol based liquids for cleaning is strictly prohibited. Throttle body cleaning every 10000 kms (12 months or earlier as required)										

I - Inspect (Clean and lubricate if necessary) A - Adjust (If Necessary) L - Lubricate R - Replace C - Clean T - Re-tighten (#) - After First service, Engine oil and Engine oil filter replacement is a mandatory at every 12 months even the vehicle has not covered the specified kms.

NOTE

- For Maintenance after 50,000 kms, Please repeat the same frequency specified above, in consultation with a Royal Enfield Authorized Dealer/Service Center.

EMS ADAPTATION PROCEDURE

The following procedure to be followed when if any change in the EMS sensors or fuel type

Step 1 - Check for Engine Oil Temperature (EOT) at start is less than **40 °C**.

Step 2 - Allow the engine to idle and leave it undisturbed till the Engine Oil Temperature reaches 115 °C. (Time required for the EOT to reach **115 °C** will be 30 minutes approximately)

Step 3 - Once Engine Oil Temperature reaches **115 °C**, turn "**OFF**" the ignition key and **DO NOT** turn it back ON for the next 30 seconds.

GENERAL AND SPECIAL TOOLS

CONTENTS

PAGE

4. General and Special Tools	33
4.1 General Tools.....	33
4.2 Measurement Tools.....	36
4.3 Special Tools.....	38
4.3.1. Engine	38
4.3.2. Vehicle	40

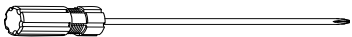
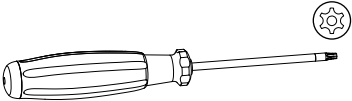
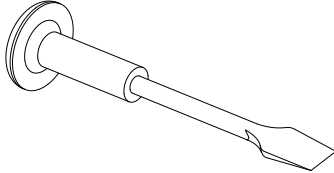
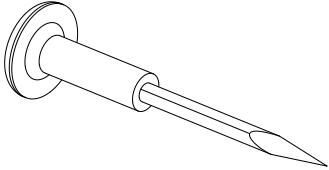
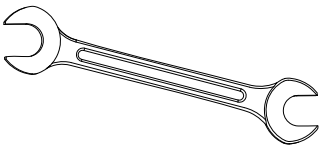
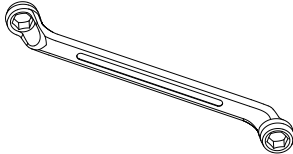
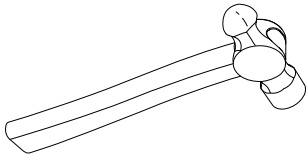

1. General and Special Tools

1.1 General Tools

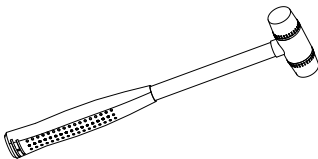
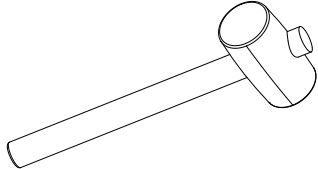
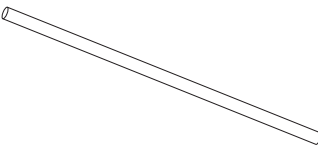
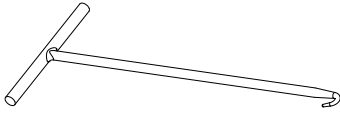
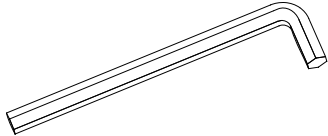
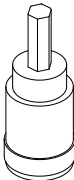
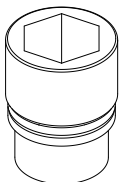
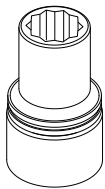
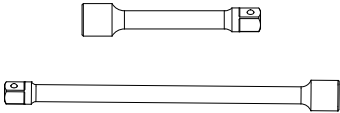

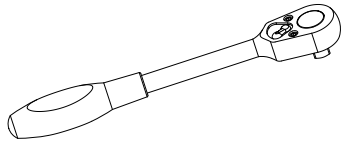
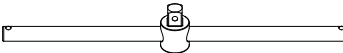
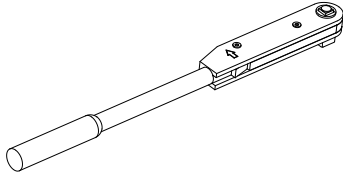
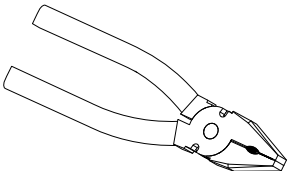
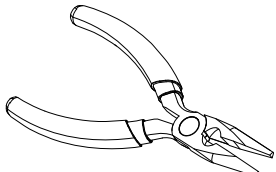
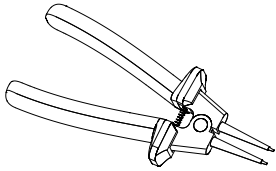
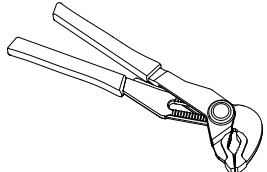
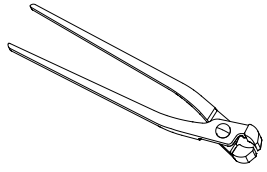
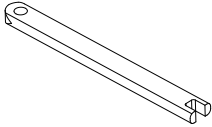
Sl. No.	Size	Part Description	Illustration
1	100 - 225mm	Screw Driver	
2	100 - 225mm	Screw Driver Phillips	
3	T20	Screw Driver (Torx)	
4	-	Chisel Flat	
5	-	Chisel Pointed	
6	6-7 to 26-27mm	Spanner (Double End/Open End)	
7	8-9 to 24-25mm	Spanner (Ring)	
8	-	Hammer	

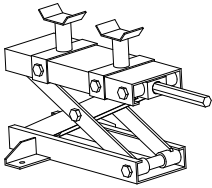
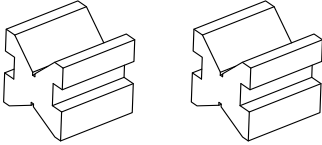
Sl. No.	Size	Part Description	Illustration
9	-	Plastic Hammer	
10	-	Mallet	
11	-	Tommy Bar	
12	-	Spring Puller	
13	4 - 14mm	Allen Key	
14	4 - 14mm	Allen Socket	
15	8 to 30mm	Hex Socket	
16	12mm	Bi-hexagonal	
17	5" & 10"	Extension	

Sl. No.	Size	Part Description	Illustration
18	-	Ratchet	
19	-	T-handle	
20	10 - 50N-m & 22 - 100N-m	Torque Wrench	
21	-	Cutting Plier	
22	-	Nose Plier	
23	-	Circlip Plier	
24	-	Adjustable Plier	
25	-	Pinch Plier	
26	-	Spoke Adjuster	

Sl. No.	Size	Part Description	Illustration
27	-	Scissor Jack	
28	-	V-block	
29	10 N-m - 200 N-m	Digital Torque Wrench	

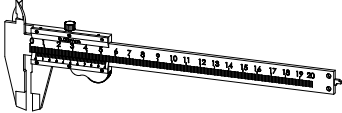
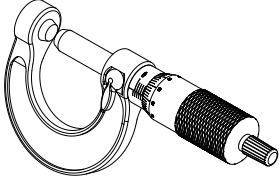
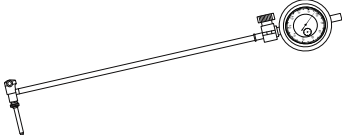
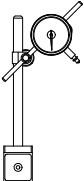
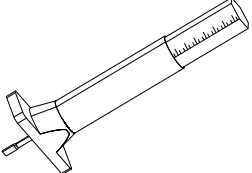

1.2 Measurement Tools

1	-	Vernier Caliper	
2	0 - 25mm, 25 - 50mm, 50 - 75mm, 75 - 100mm	Micrometer	
3	-	Bore Gauge	
4	-	Dial Gauge with Magnetic Stand	
5	-	Tyre Depth Gauge	
6	-	Steel Ruler	

SPECIAL TOOLS

1.3 Special Tools

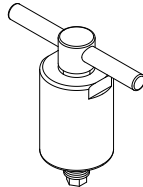
1.3.1. Engine

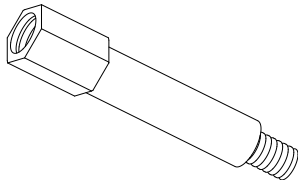
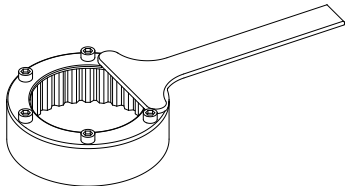
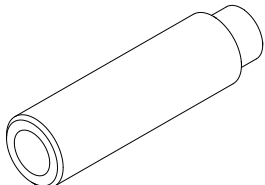
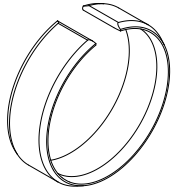
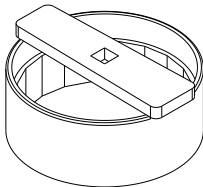
I. No.	Part Number	Part Description	Illustration
1	ST30274/a	Magneto Puller Assembly	
2	ST275332	Crank Gears Locking Tool	
3	ST30259/a	Adapter - Compression Checking	
4	ST30266/a	Clutch Holder	
5	ST30271/a	Gear Shifter Shaft NRB and Oil Seal Installer	
6	ST30296/a	Piston Ring Compressor	
7	ST30294/a	Oil Filter Wrench	

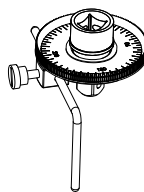
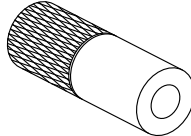
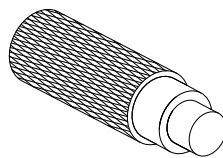
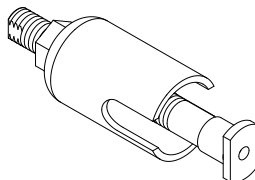
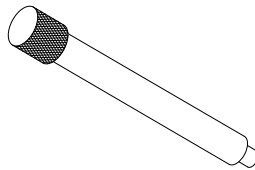
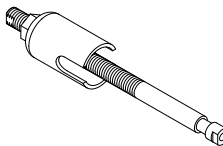
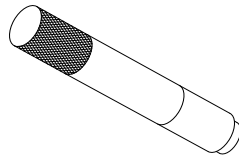
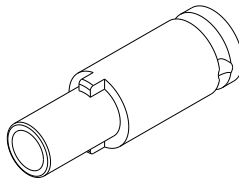
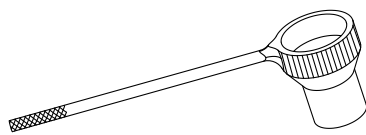
Sl. No.	Part Number	Part Description	Illustration
8	ST-27562-1	Angular Torque Wrench	
9	ST30264/a	Clutch Activating Shaft Oil Seal Installer	
10	ST30262/a	Clutch Activating Lever Top Bearing Installer	
11	ST-27540-1	Clutch Activating Shaft Top Bearing Puller	
12	ST30261/a	Clutch Activating Lever Bottom Bearing Installer	
13	ST30263/a	Clutch Act Shaft Bottom Bearing Puller	
14	ST30270/a	Gear Shifter Drum NRB Installer	
15	ST30293/a	Oil Filter Union Wrench	
16	ST-27527-2	Tappet Adjusting Tool	

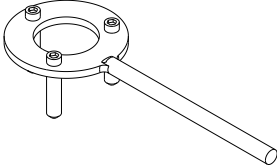
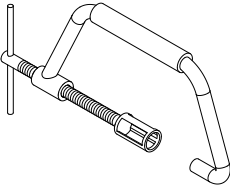
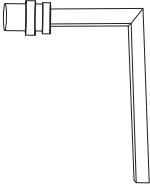
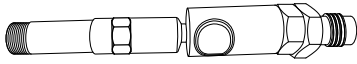
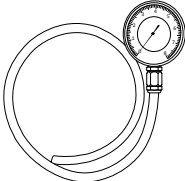
SL. No.	Part Number	Part Description	Illustration
17	ST-27534-2	FD Sprocket Holding Tool	
18	ST-27528-2	Valve Spring Compressor	
19		Magnet Holder	
20		Oil Pressure Adapter	
21		Oil Pressure Gauge	

1.3.2. Vehicle

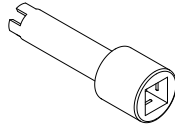
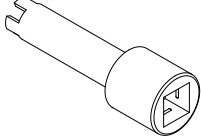
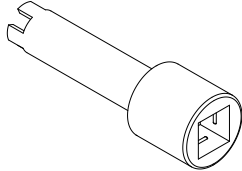
SI. No.	Part Number	Part Description	Illustration
1	ST30267/a	Frame Adjuster OD 14.8/ ID 10.8 mm-Engine	
2	ST30268/a	Frame Adjuster OD 16.7/ ID 13 mm-Engine	
3	ST30269/a	Frame Adjuster OD 21.5/ ID 18 mm-Swingarm	

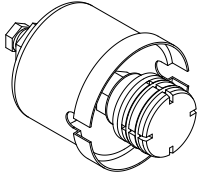
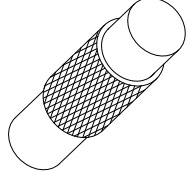
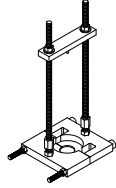
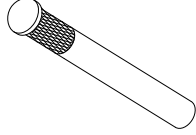
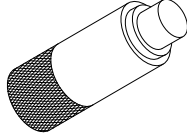
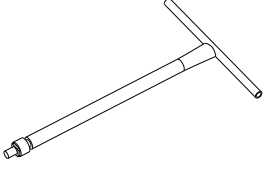
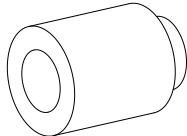
4	ST30272/a	Headstock Bearing Puller-Assembly	
5	ST30273/a	Headstock - Frame Cone Installer	
6	ST30298/a	Bearing Puller, T -Stem	
7	ST30299/a	T Stem Taper Roller Bearing Installer	
8	ST30297/a	Swing Arm NRB Installer	
9	ST26461-2	Fork Damper Tube Holder	
10	ST26485-3	Fork Oil Seal Installer	

ENGINE

CONTENTS

PAGE

5.1. ENGINE REMOVAL FROM FRAME	45
5.2. ENGINE DISMANTLING	62
5.3. ENGINE ASSEMBLY	94
5.4. ENGINE ASSEMBLY TO FRAME	127
5.5. ENGINE INSPECTION	144

ENGINE REMOVAL FROM FRAME

Engine Removal from Frame

CONTENTS	PAGE
5.1 Engine Removal from Main Frame.....	47
5.1.1. Engine Oil.....	47
5.1.2. Oil Filter	47
5.1.3. Side Panel RH.....	48
5.1.4. Side Panel LH	48
5.1.5. Pillion and Rider Seat from Frame.....	48
5.1.6. Grab Rail from Frame	49
5.1.7. Battery Connections	49
5.1.8. Clutch Cable.....	50
5.1.9. Fuel Tank.....	51
5.1.10. Fuel Pump Connector	51
5.1.11. Fuel Hose (Fuel Pump to Injector)	52
5.1.12. EVAP Connections to Fuel Tank.....	52
5.1.13. Drain Hose.....	52
5.1.14. Throttle Cable.....	52
5.1.15. Air Filter Housing to Throttle Body	53
5.1.16. Throttle Body	53
5.1.17. Hego/Oxygen Sensor Connectors.....	53
5.1.18. Exhaust Pipe and Silencer	54
5.1.19. Magneto/Gear Position/Side Stand.....	55
5.1.20. Starter Motor Connection	56
5.1.21. Spark Plug Suppressor Cap	56
5.1.22. Breather Hose Connection	56
5.1.23. Gear Shift Linkage.....	57
5.1.24. FD Sprocket Cover and FD Sprocket	57

Engine Removal from Frame

CONTENTS	PAGE
5.1.25. Rear Wheel (Increasing chain slack)	58
5.1.26. Remove Rear Chain from FD Sprocket	58
5.1.27. Gear Position Sensor	59
5.1.28. Cradle Frame Mountings	59
5.1.29. Engine from Main Frame	60

1.1 Engine Removal from Main Frame

⚠ WARNING

The engine and exhaust system get extremely hot during normal operation and direct contact with skin can cause serious burns. Make sure engine is in normal temperature (OR) cooled before starting operation.

1.1.1. Engine Oil

NOTE

- Ensure the motorcycle is placed on a firm flat surface, resting it on the center stand/ramp.

- Before starting the dismantling process, start the engine and let the engine warm up for a few minutes and then turn it OFF.
- Remove engine oil filler cap.

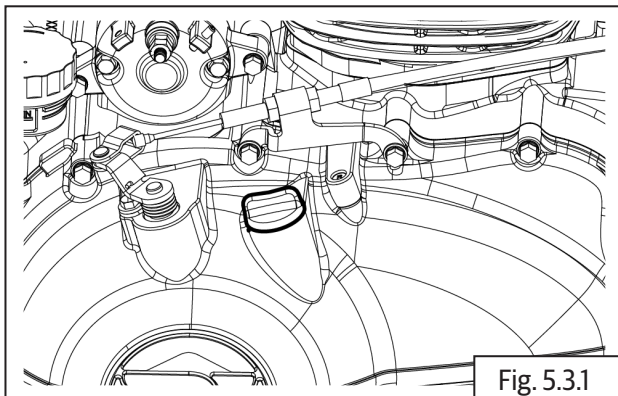

- Place a tray under engine oil drain plug (M6). Remove bolt (a) along with cap (b) and O-ring (c).

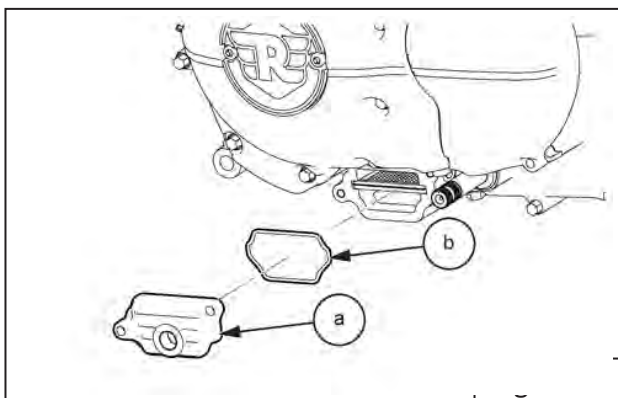

8 mm Socket with Ratchet

- Gently pull and remove stainer (a).

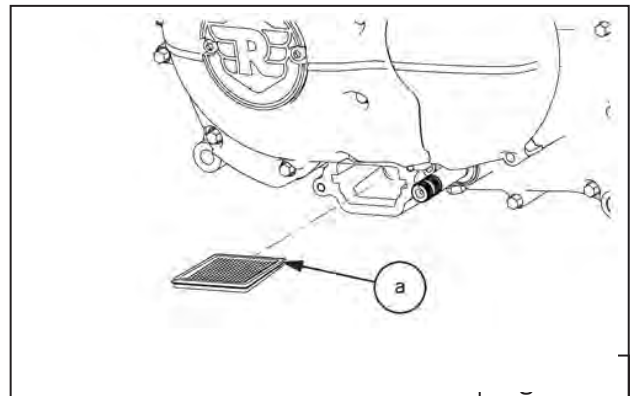

1.1.2. Oil Filter

- Place a tray under engine cover RH.
- Loosen and remove 3 Nos Hex soc bolt (M6) (a) from cover RH.

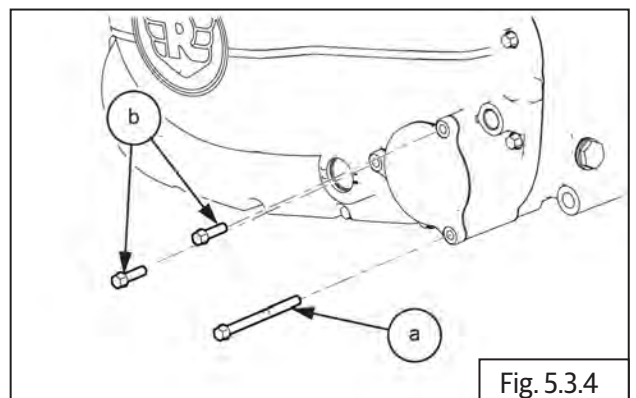

8 mm Socket with Ratchet

- Gently remove oil filter cap (a) along with O-ring (b).

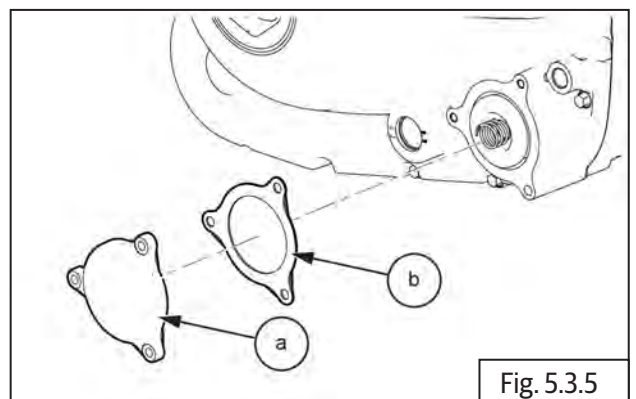

- Gently remove oil filter **(a)**.

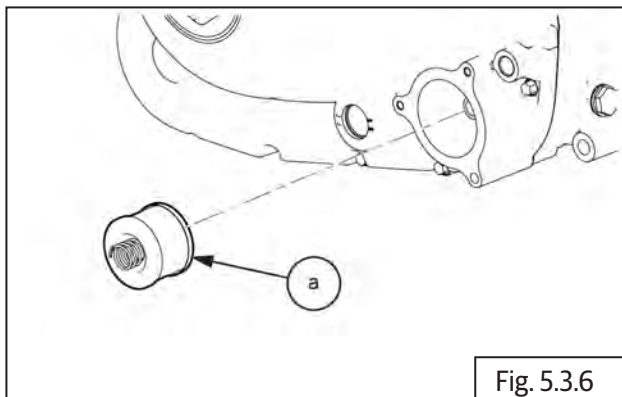

Fig. 5.3.6

1.1.3. Side Panel RH

- Remove 3 Nos. Hex socket button head screws **(a)** (except left bottom one)

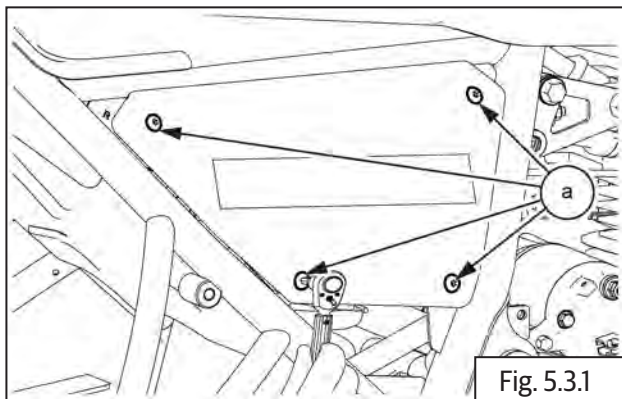

Fig. 5.3.1



5 mm Allen Key

1.1.4. Side Panel LH

- Remove 3 Nos. Hex socket button head screws **(a)** (except left bottom one)

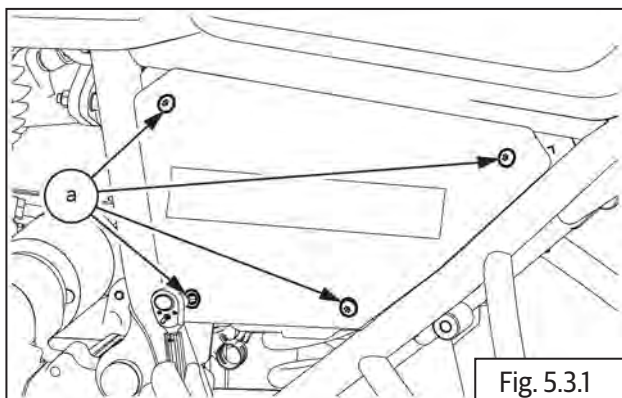

Fig. 5.3.1



5 mm Allen Key

- Gently pull the LH cover **(a)** to remove.

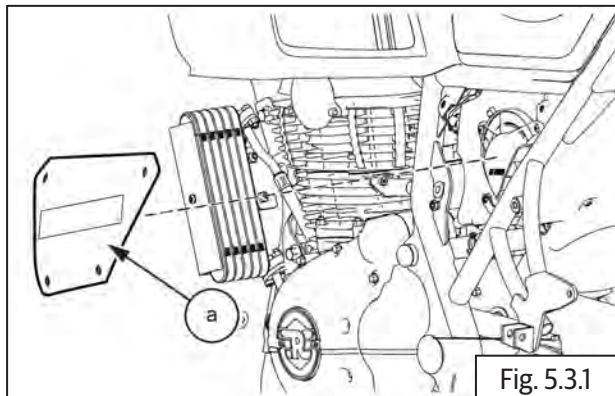

Fig. 5.3.1

1.1.5. Pillion and Rider Seat from Frame

- Insert ignition key and turn clockwise to unlock.

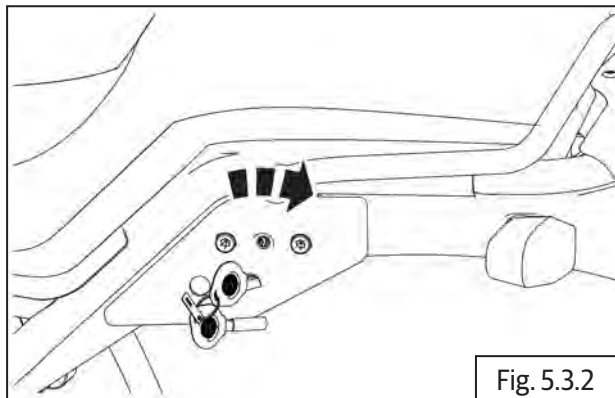

Fig. 5.3.2

- Remove pillion seat **(a)**.

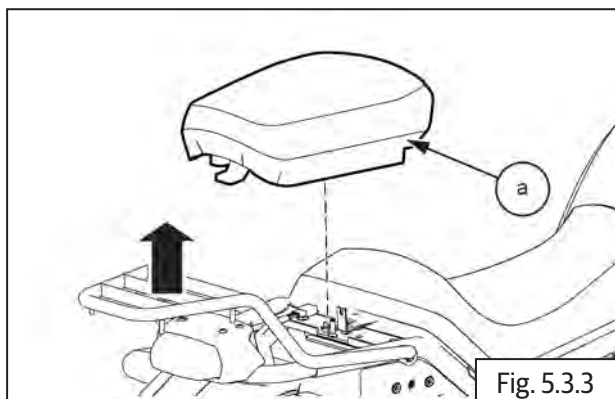
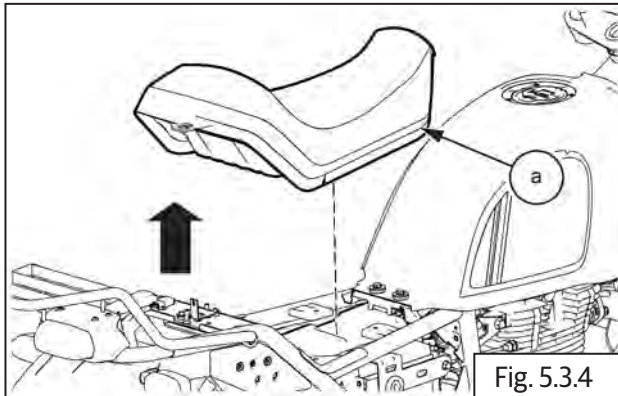

Fig. 5.3.3

- Gently pull and remove rider seat **(a)**.



NOTE

- Place the seat in a safe location to prevent from scratches and dirt.

1.1.6. Grab Rail from Frame

- Remove the 1 No. allen bolt (a) on both RH and LH side from the grab rail.

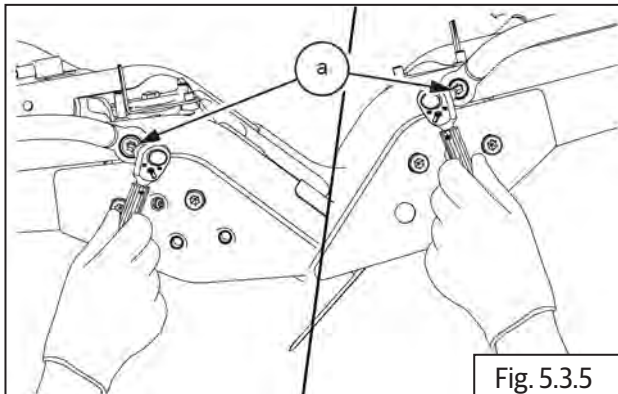

10 mm Socket with Ratchet

- Remove the 2 Nos. allen bolts **(a)** from the mudguard.

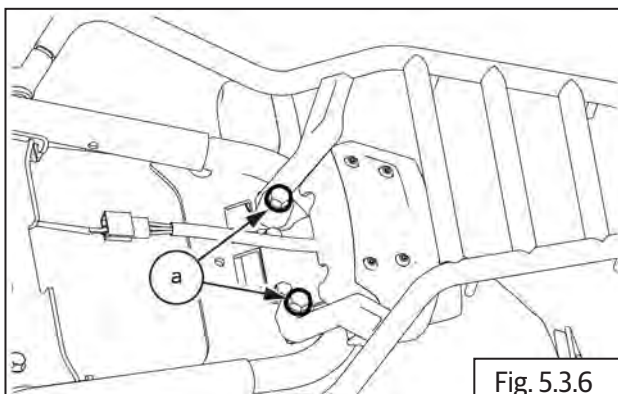

- Gently remove the grab rail **(a)**.

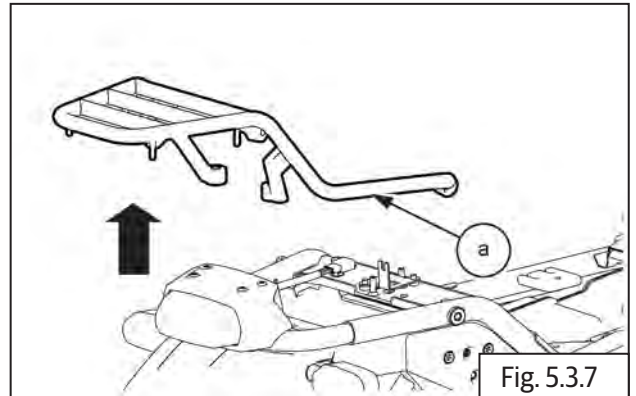

1.1.7. Battery Connections

NOTE

- Ensure ignition and stop switches are in OFF position before disconnecting battery cables.

- Disconnect battery negative (-) terminal bolt **(a)**.

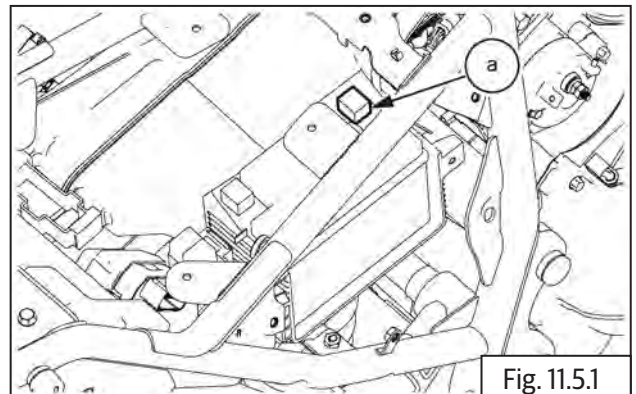

10 mm Double end spanner

- Disconnect battery positive (+) terminal **(a)** from battery **(b)**.

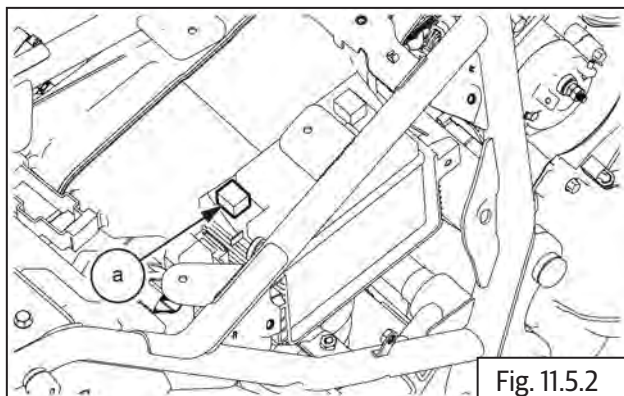

Fig. 11.5.2



10 mm Double end spanner

1.1.8. Clutch Cable

Cover RH End

⚠ CAUTION

Ensure the motorcycle is upright on a firm and flat surface.

- Ensure ignition switch and engine stop switch are in OFF position.
- Loosen lock nut and ensure adjuster **(a)** at the handlebar end is fully turned into the bracket LH to increase cable play.

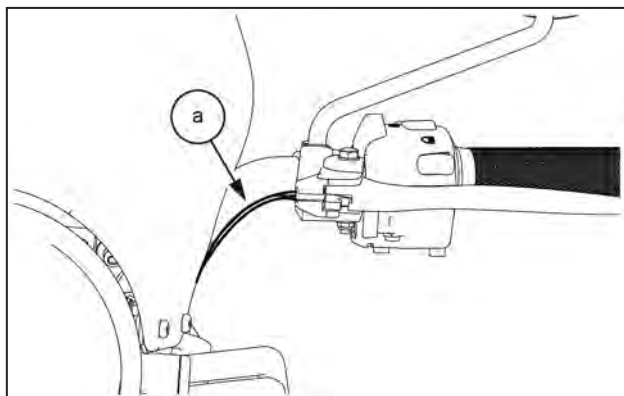

- Loosen outer locknut **(M8) (a)** completely on the clutch cable adjuster at RH cover end and push clutch cable **(b)** into cable guide in cover RH to increase the free play of the inner cable.

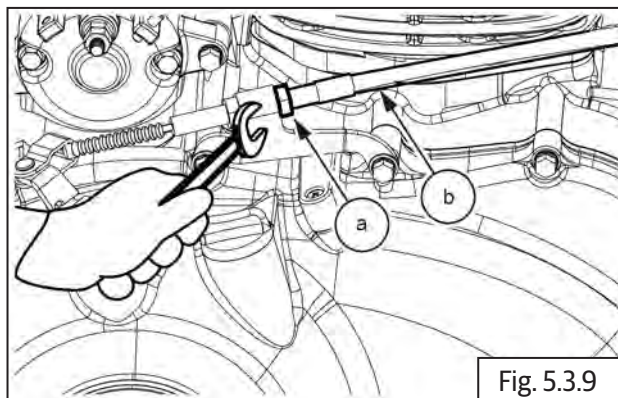

Fig. 5.3.9



12 mm Double end spanner

- Gently push inner cable **(a)** into clevis **(b)** in clutch shaft **(c)** and remove cable through the slot in the clevis.

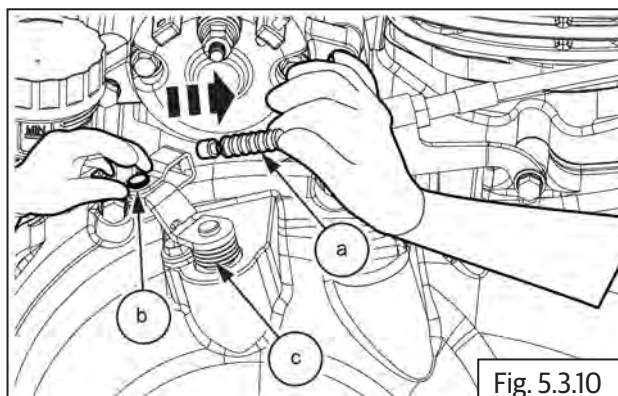

Fig. 5.3.10

- Remove protective rubber boot **(a)** from clutch cable **(b)**.

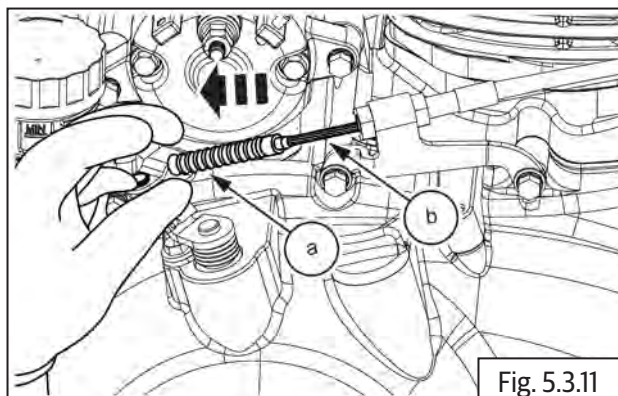

Fig. 5.3.11

- Loosen adjuster nut **(a)** completely from the clutch cable and remove.

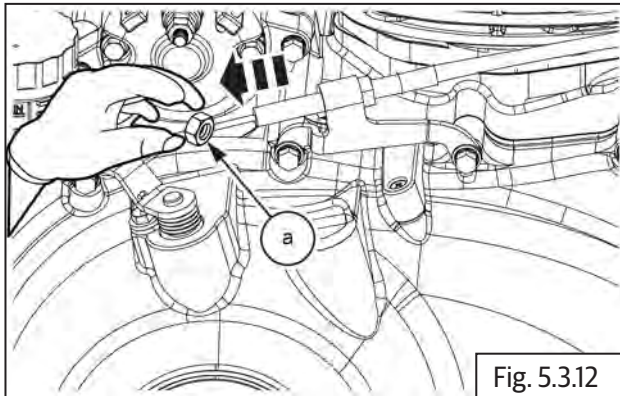

Fig. 5.3.12

- Gently pull out clutch cable assembly **(a)** from the cable guide **(b)** in cover RH assembly.

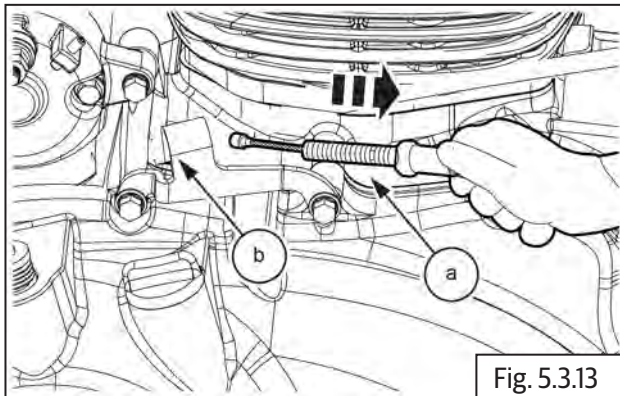

Fig. 5.3.13

1.1.9. Fuel Tank

- Ensure the ignition and stop switches are in OFF position.
- Remove the fuel tank cap. Drain fuel completely from fuel tank.
- Remove the following parts:
 - Remove side panel RH ([section 6.7.1](#)).
 - Remove rider seat ([section 6.7.2](#)).
- Loosen and remove 2 Nos. Hex head bolts **(M6)** **(a)** from rear end of fuel tank on frame **(b)**.

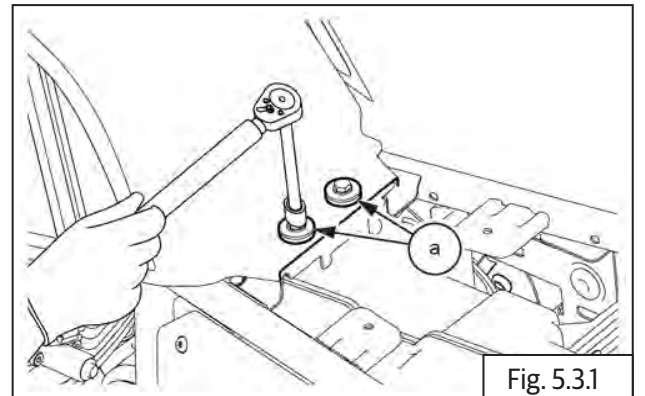

Fig. 5.3.1



10 mm Socket with Ratchet

1.1.10. Fuel Pump Connector

- Gently lift fuel tank **(a)** upwards and pull backwards slightly.
- Disconnect fuel pump connector **(b)** from fuel tank.

! CAUTION

DO NOT lift the tank too much to prevent damage to connectors and brake hoses.

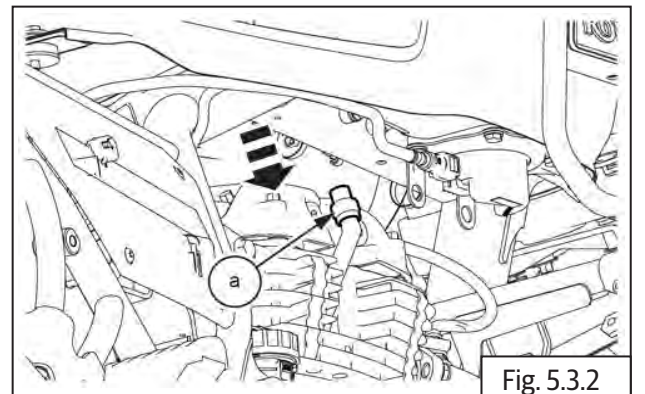
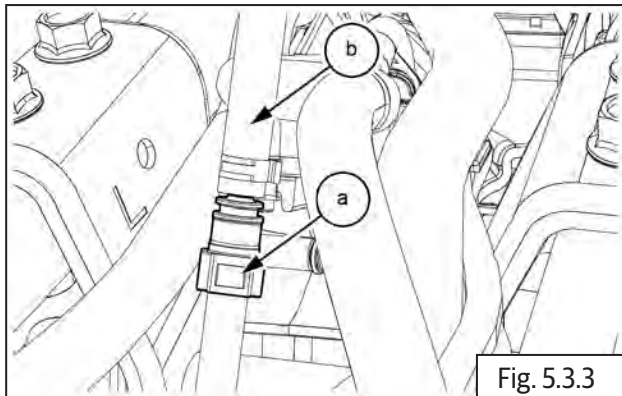

Fig. 5.3.2

1.1.11. Fuel Hose (Fuel Pump to Injector)

- Clean quick fix adapter area and disconnect by pressing lock button **(a)**. Remove fuel hose **(b)**.



1.1.13. Drain Hose

- Disconnect drain hose connection **(a)** from fuel tank **(b)**.

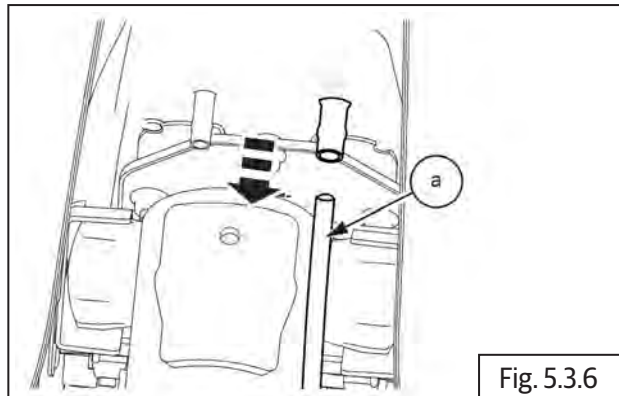

1.1.14. Throttle Cable

Throttle Body End

⚠ CAUTION

Ensure the motorcycle is upright on a firm and flat surface.

- Ensure Ignition switch and Engine stop switch are in OFF position.
- Remove side panel LH ([Section 6.7.1](#)).
- Remove rider seat ([Section 6.7.2](#)).
- Loosen fuel tank assembly mountings ([Section 7.1.1](#)) and carefully slide and lift fuel tank up to access 2 clips holding the throttle cables to frame on RH side.
- Loosen 2 Nos. Hex nuts **(M8) (a)** fully on top of throttle cable bracket **(b)** to increase inner cable **(c)** free play.

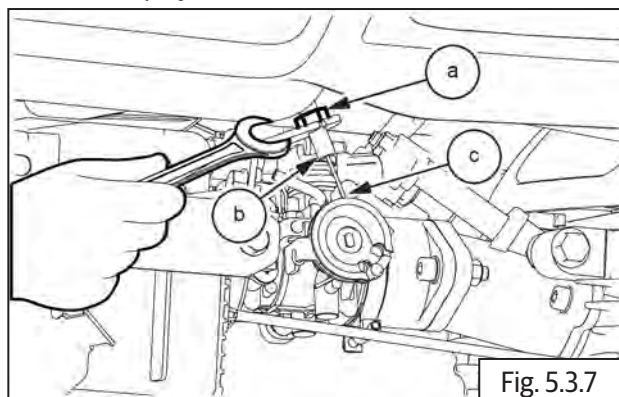

10 mm Double end spanner

1.1.12. EVAP Connections to Fuel Tank

- Disconnect EVAP connection hose **(a)** from fuel tank **(b)**.

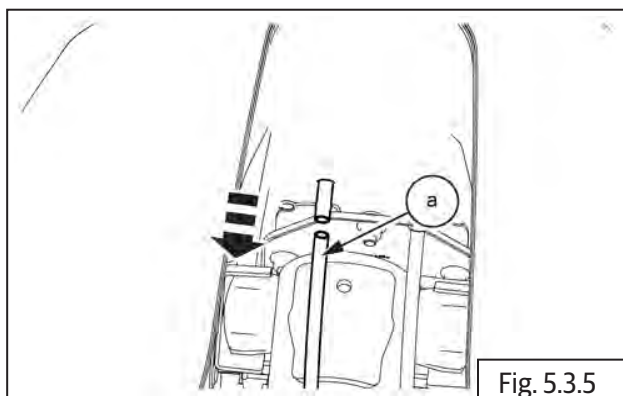

- Push cable adjusters fully into the bracket and loosen the 2 inner hex nuts **(a)** (**M6**) on the throttle cable adjusters.
- Ensure both inner nuts are free from the adjusters and gently pull out the adjuster of the inside cable till it is out of the bracket and slide the inner cable out through the slot in the bracket.

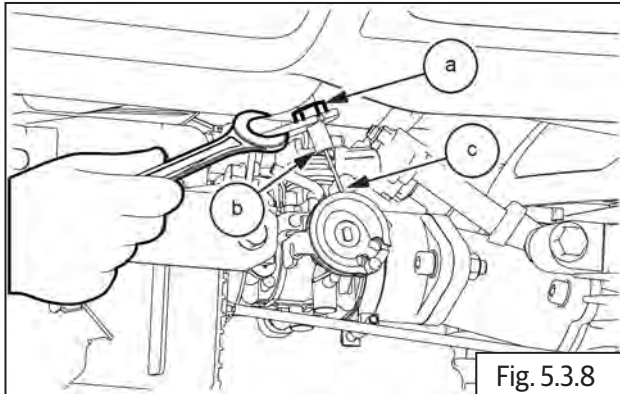

Fig. 5.3.8

1.1.15. Air Filter Housing to Throttle Body

- Remove 1 No. Allen bolt **(a)** from the throttle body **(b)**.

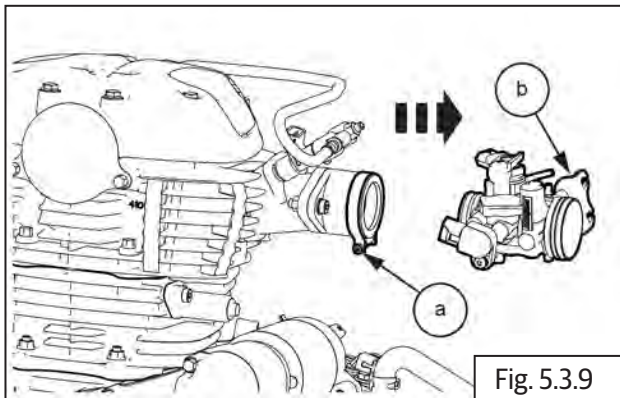

Fig. 5.3.9



4mm Allen Socket and Ratchet

1.1.16. Throttle Body

- Ensure throttle position sensor, manifold absolute pressure sensor and idle speed controller wiring connectors are disconnected.
- Disconnect the hoses **(a)** from canister purge valve.
- Loosen worm clip screws **(M5)** **(b)** to disconnect throttle body from inlet manifolds.

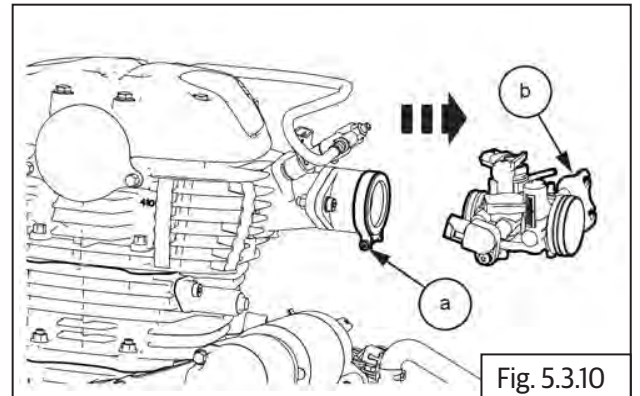

Fig. 5.3.10



4 mm Allen key

1.1.17. Hego/Oxygen Sensor Connectors

- Disconnect Hego/oxygen sensor connectors **(a)** from both LH and RH located on front side of engine.

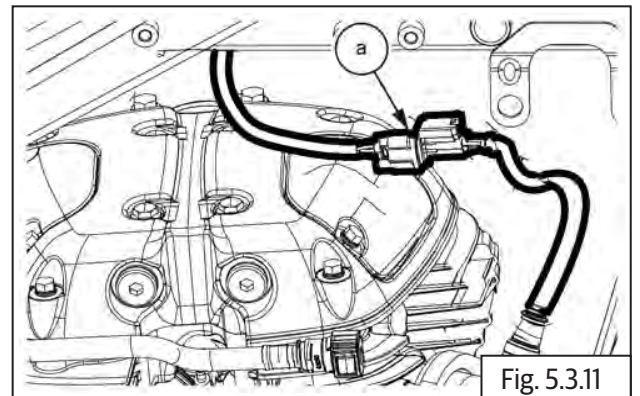
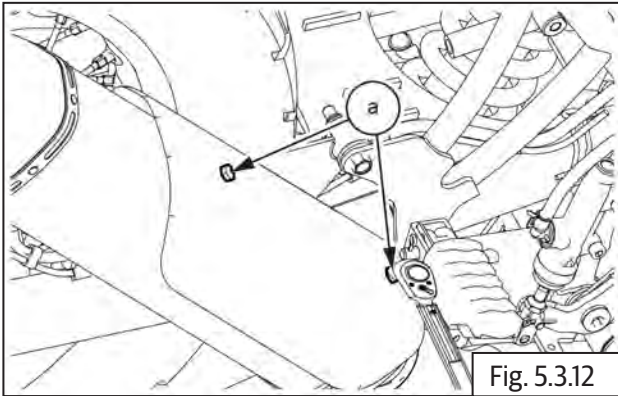

Fig. 5.3.11

1.1.18. Exhaust Pipe and Silencer

Silencer

- Loosen and remove 2 Nos. hex socket bolts **(M6)** **(a)** from the silencer guard at muffler end.



10 mm socket with ratchet

- Remove silencer guard **(a)** along with bolts **(b)**.

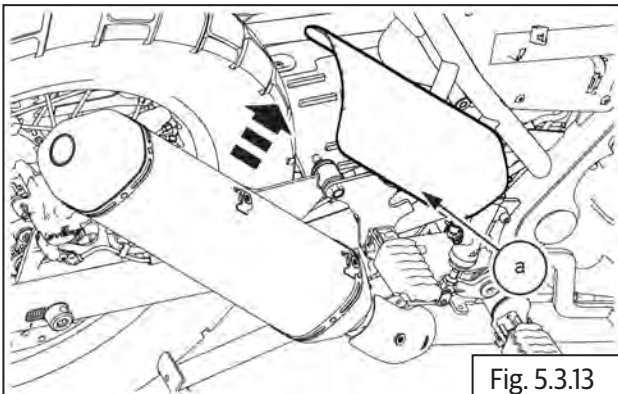

- Remove 2 nos hex socket bolts **(a)** **(M6)** from silencer guard at the header pipe end.

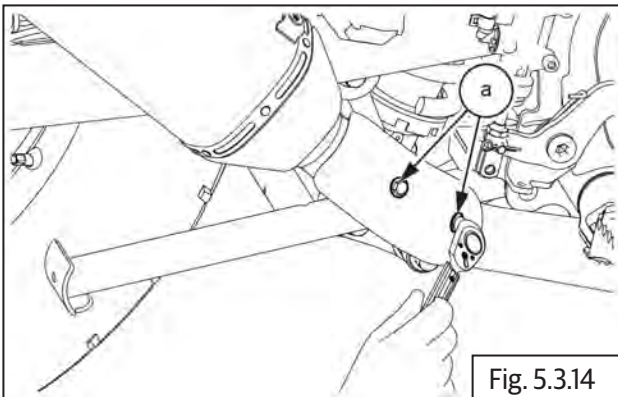

10 mm socket with ratchet

- Remove the silencer guard along with bolts.

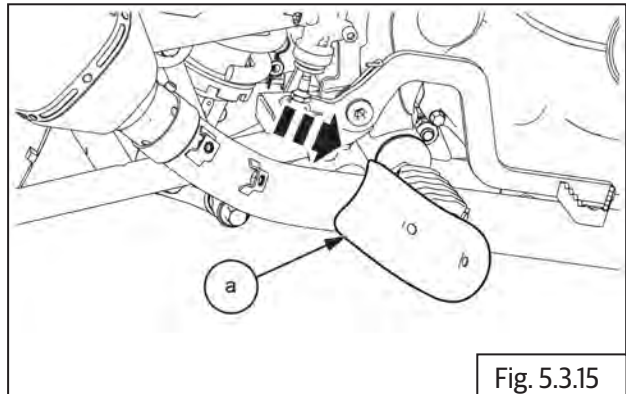

- Remove the header pipe mounting bolt **(a)**.

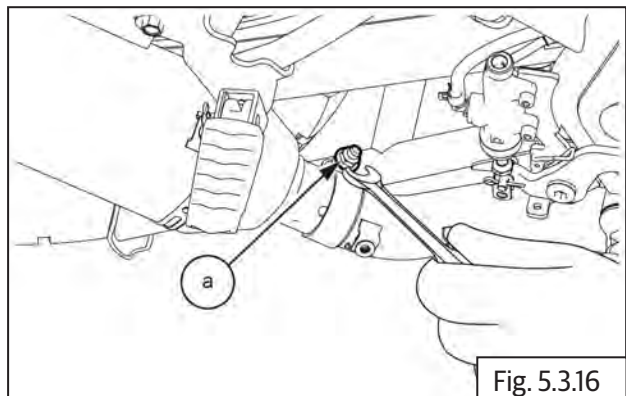

12 mm socket with ratchet

- Remove silencer mounting **(a)** from frame.

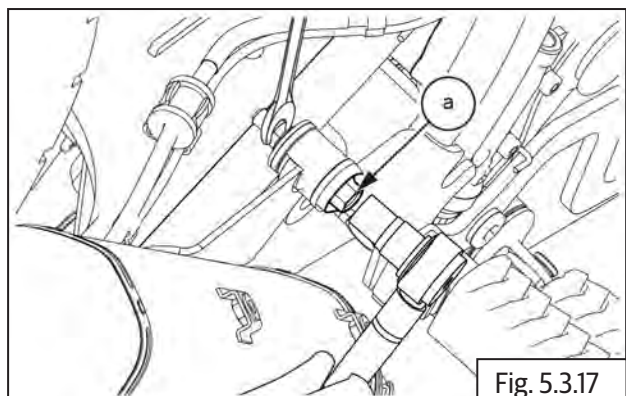

12 mm socket with ratchet

- Gently pull the silencer outwards to remove.

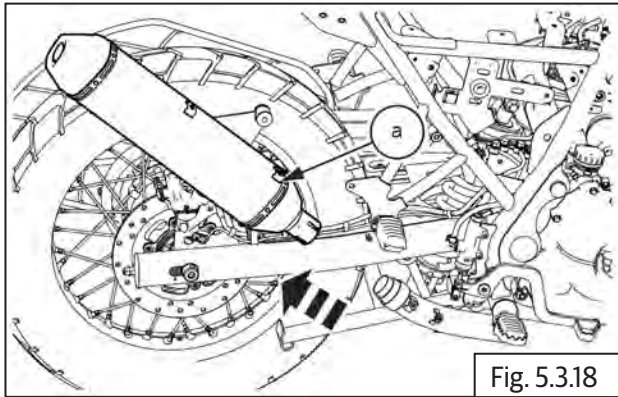

Fig. 5.3.18

7.4.1. Exhaust Header Pipe

- Remove 2 nos nuts **(a)** from the cylinder head assembly.

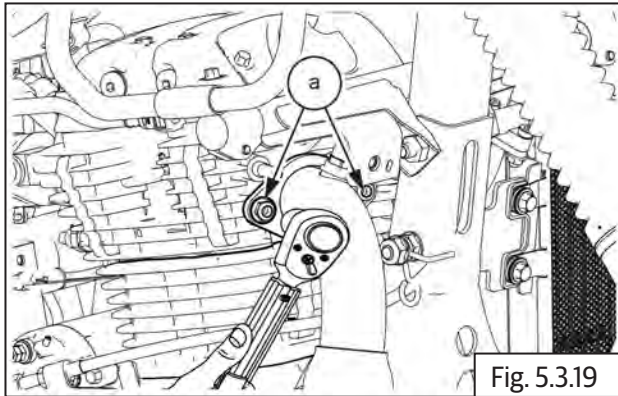

Fig. 5.3.19



14 mm socket with ratchet

- Remove the exhaust header pipe **(a)**.

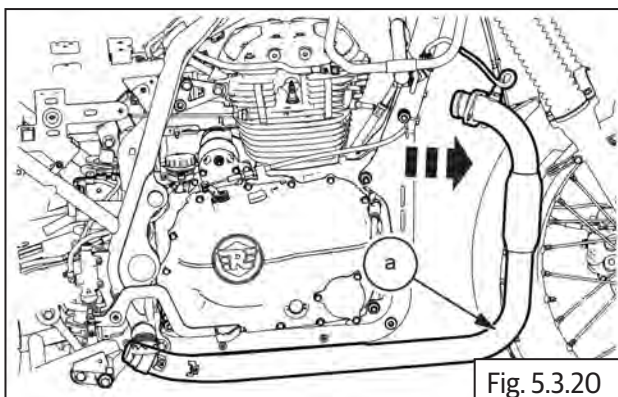

Fig. 5.3.20

⚠ CAUTION

Perform any action in exhaust pipe only after the exhaust pipe cools down.

7.4.2. O2 Sensor

- Refer headlamp dismantling section to remove O2 sensor socket.
- Loosen and remove O2 sensor **(a)** from the header pipe.

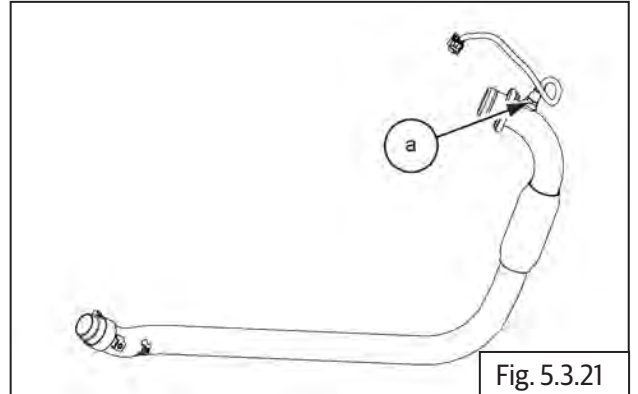

Fig. 5.3.21



17 mm open end spanner

1.1.19. Magneto/Gear Position/Side Stand

Magneto/Gear Position/Side Stand Switch Couplers Connections

- Disconnect wiring coupler **(a)** of gear position sensor from main wiring harness **(b)**.

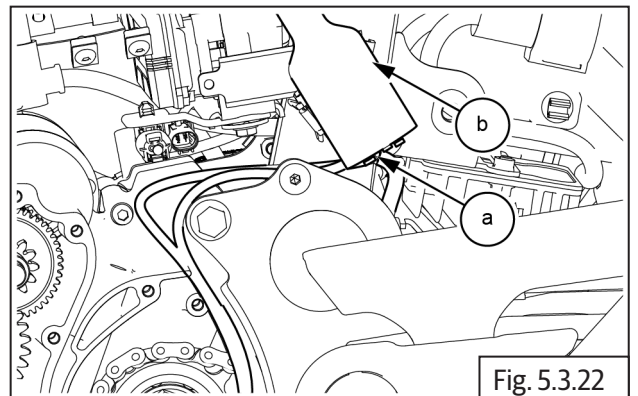

Fig. 5.3.22

- Disconnect wiring coupler **(a)** of stator from main wiring harness.

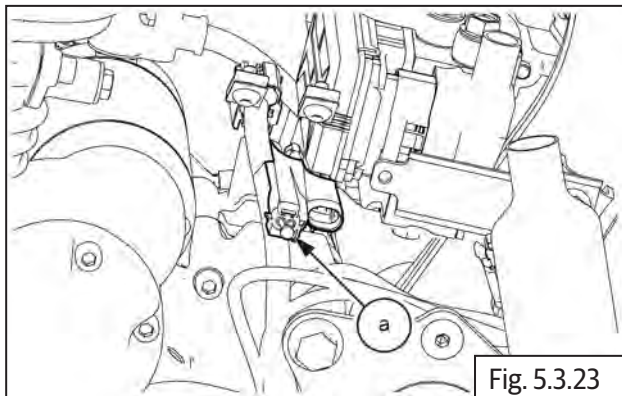

Fig. 5.3.23

- Disconnect side stand connector **(a)** from wiring harness located behind engine .

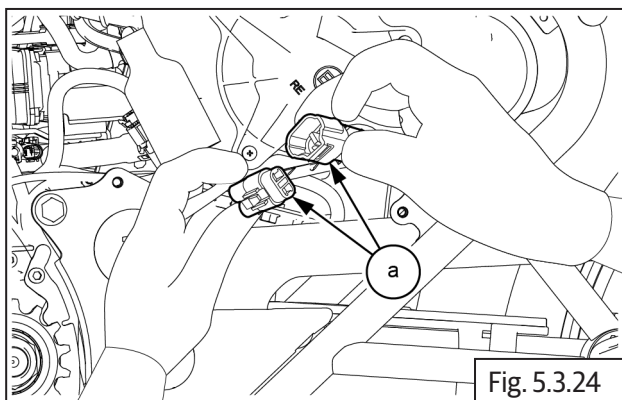

Fig. 5.3.24

1.1.20. Starter Motor Connection

- Loosen and remove Hex nut **(M6) (a)** from starter motor **(b)** to disconnect positive (+) terminal.

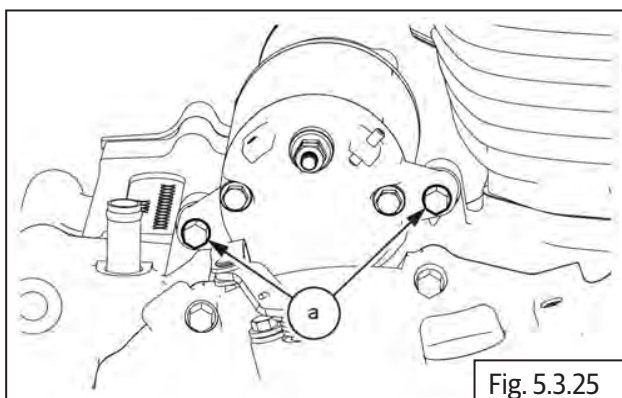

Fig. 5.3.25



10 mm Ring Spanner

- Loosen and remove 2 Nos. Hex flange head bolt **(M6) (a)** to disconnect starter motor **(b)** negative (-) terminal.

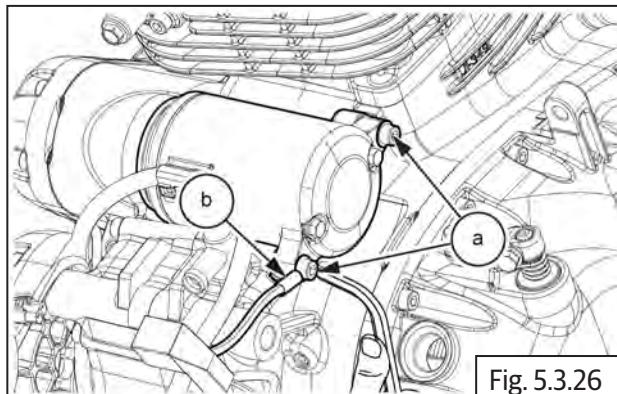

Fig. 5.3.26



10 mm Ring spanner

1.1.21. Spark Plug Suppressor Cap

- Disconnect spark plug suppressor from the spark plug **(a)**.

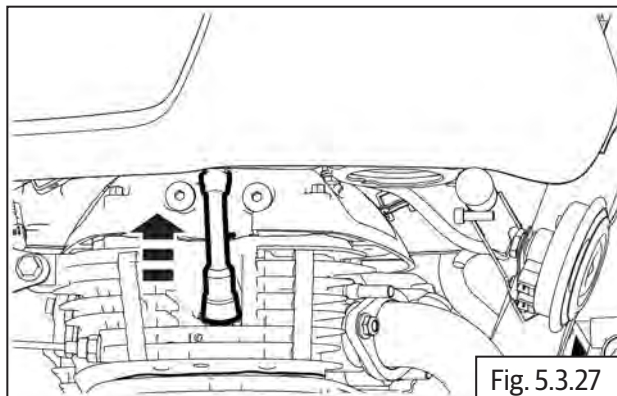

Fig. 5.3.27

1.1.22. Breather Hose Connection

- Release the clamp **(a)** to disconnect breather hose **(b)** from air filter box.

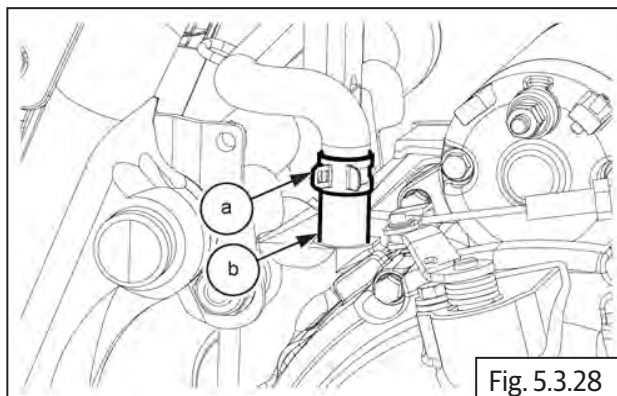

Fig. 5.3.28



Nose plier

1.1.23. Gear Shift Linkage

- Loosen Hex bolt **(M6) (a)** to remove gear pedal linkage **(b)**.

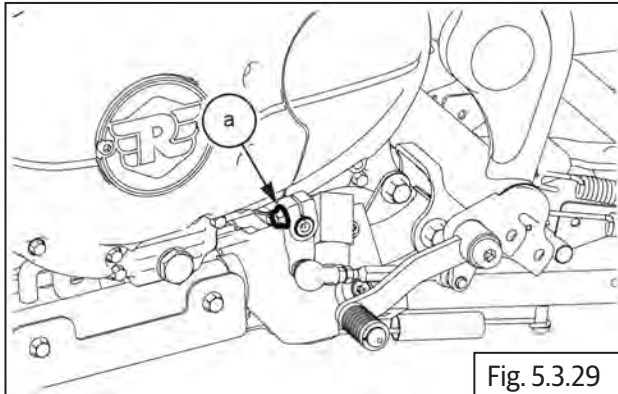

Fig. 5.3.29



10 mm Socket with Ratchet

- Loosen Hex bolt **(M10) (a)** to remove gear pedal **(b)**.

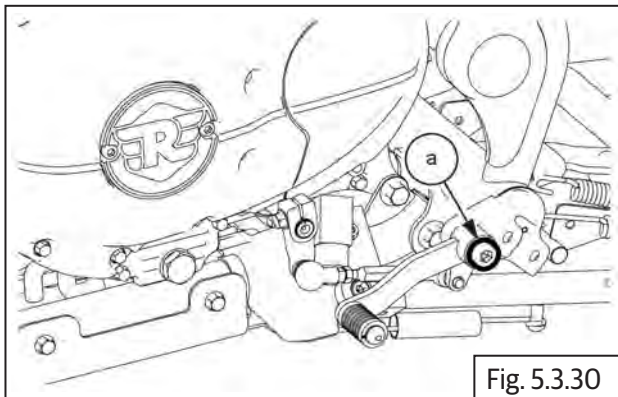

Fig. 5.3.30



14 mm Socket with Ratchet 17 mm Ring Spanner

1.1.24. FD Sprocket Cover and FD Sprocket

⚠ CAUTION

Ensure gear is in **NEUTRAL** position before dismantling.

- Remove 2 Nos. hex bolt **(M6) (a)** from the FD sprocket cover.

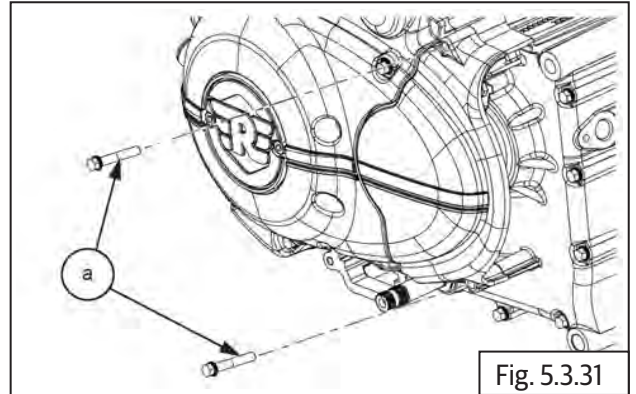

Fig. 5.3.31



5 mm Allen socket with Ratchet

- Gently pull out FD sprocket cover **(a)**.

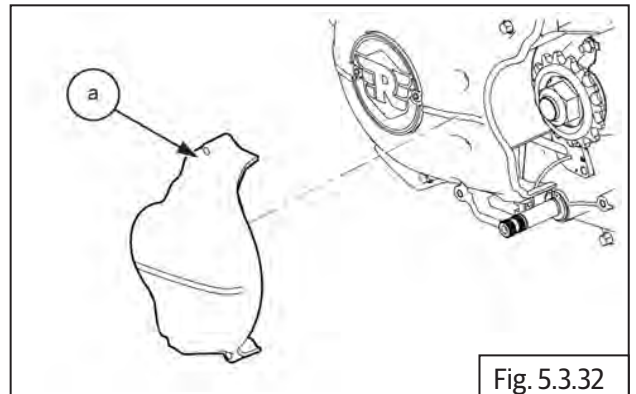

Fig. 5.3.32

- Unlock and release washer holder **(a)**.

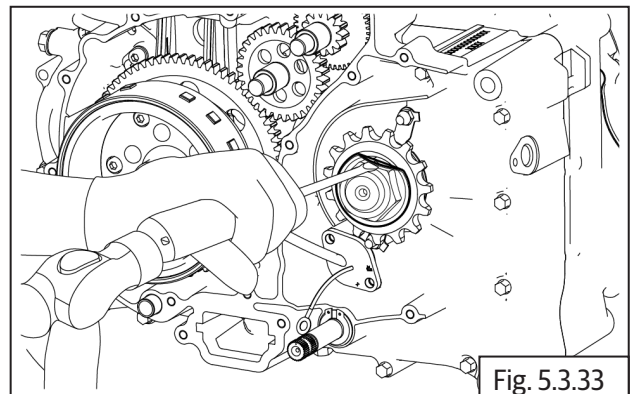

Fig. 5.3.33



Chisel and Hammer

- Apply rear brake **(a)**.

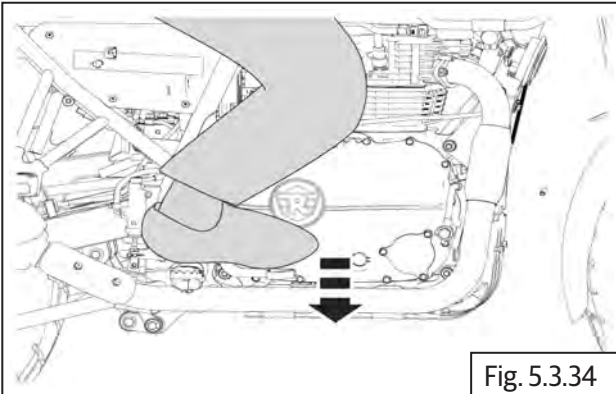

Fig. 5.3.34

- Loosen and remove FD sprocket U nut **(a)**.

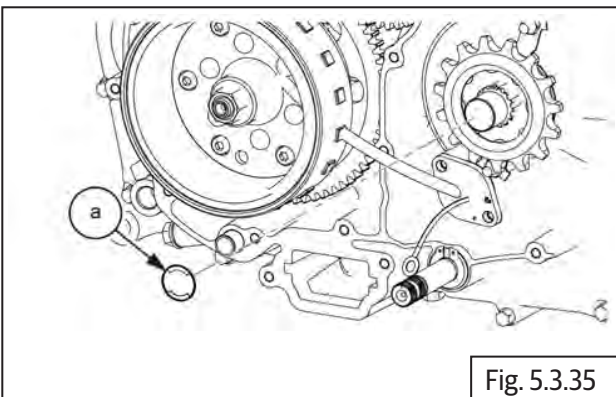

Fig. 5.3.35



30 mm socket with Ratchet

- Remove FD sprocket **(a)** from drive shaft.

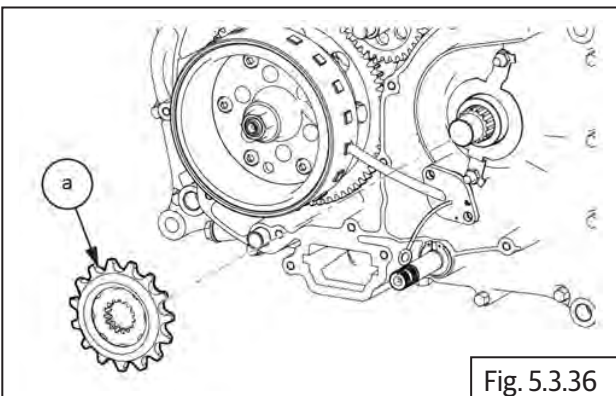

Fig. 5.3.36

1.1.25. Rear Wheel (Increasing chain slack)

- Loosen rear wheel axle nut **(M16) (a)** to increase the chain slackness/tension.

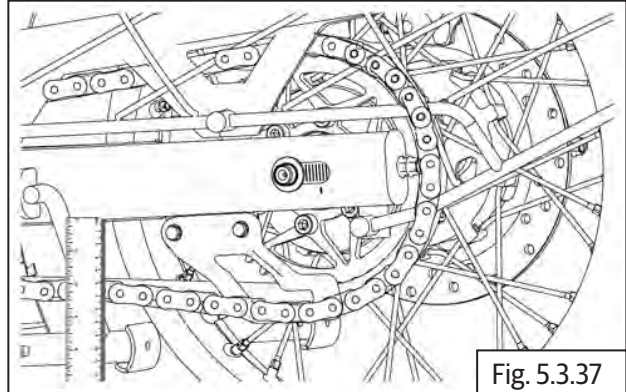

Fig. 5.3.37



24 mm Socket with Ratchet

- Loosen chain adjuster lock nut **(M8) (a)** on LH and RH.

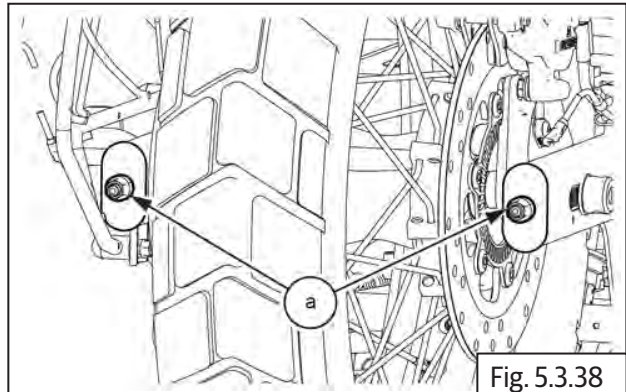

Fig. 5.3.38



6 mm Allen socket with ratchet

1.1.26. Remove Rear Chain from FD Sprocket

- Gently remove chain **(a)** from FD sprocket **(b)**.

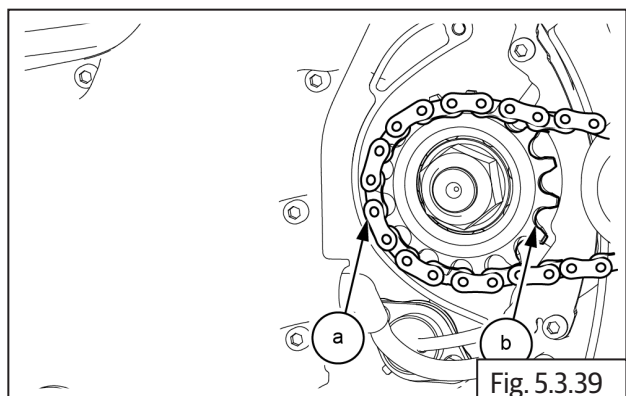
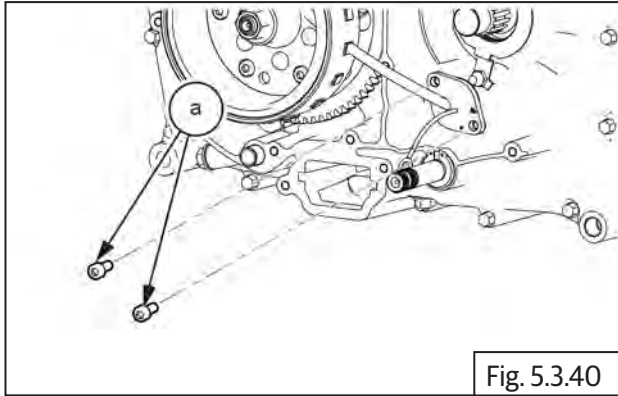

Fig. 5.3.39

1.1.27. Gear Position Sensor

- Loosen and remove 2 Nos. Hex head bolts **(M6)** **(a)** holding the gear position sensor to crankcase LH.
- Gently tap Gear Position Sensor and remove along with O-ring.



1.1.28. Cradle Frame Mountings

Cradle Frame from Main Frame and Engine

- Loosen and remove 1 Nos. Hex socket head long bolts **(M10)** **(a)** on LH on cradle frame **(b)**.

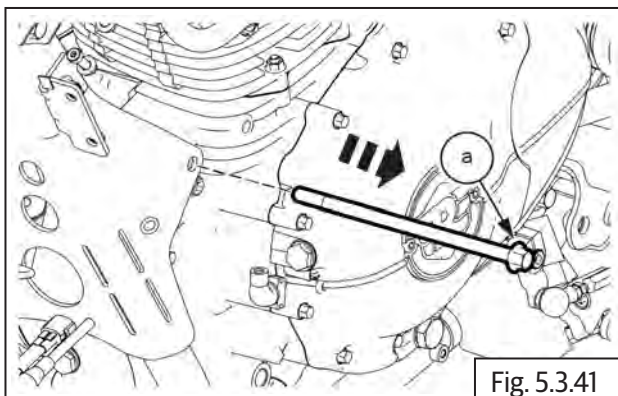

- Loosen and remove 1 Nos. Hex socket head bolts **(M8)** **(a)** on LH on cradle frame behind the engine **(b)**.

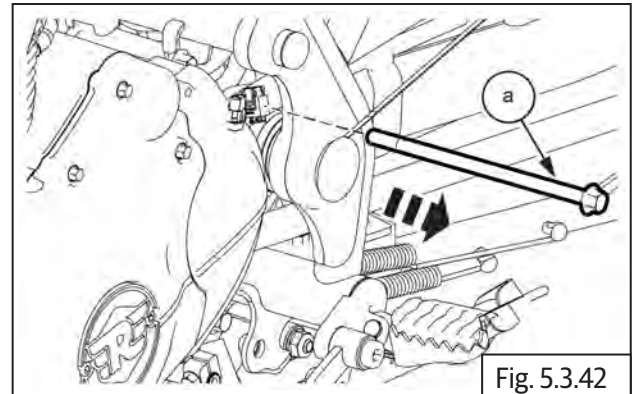

- Loosen and remove 1 Nos. Hex socket head bolt **(M10)** **(a)** along with nut **(b)** on RH on cradle frame **(c)**.

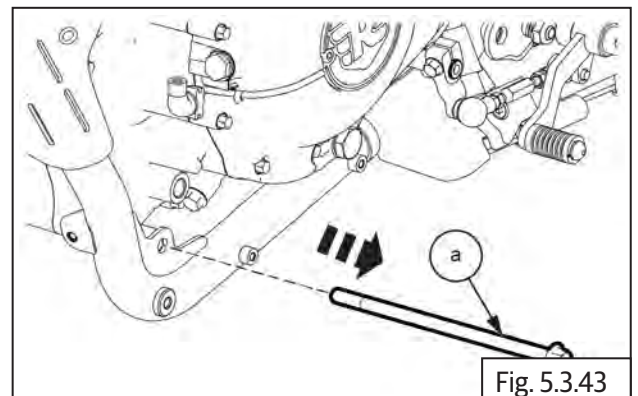

- Remove cradle frame **(a)** from engine.

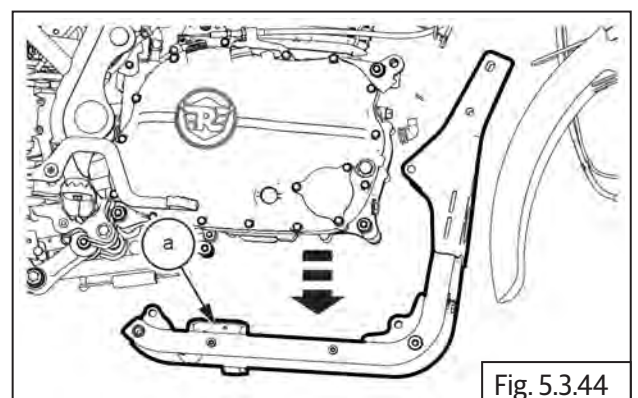

1.1.29. Engine from Main Frame

- Support engine with flat jack **(a)** so that it will not fall off when mounting bolts are removed.

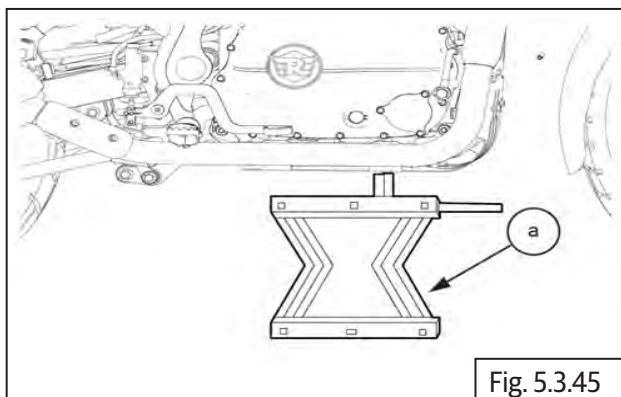

- Remove Hex head bolt **(M10) (a)** along with nut **(c)** and washers **(b)** from engine front top mounting to frame .

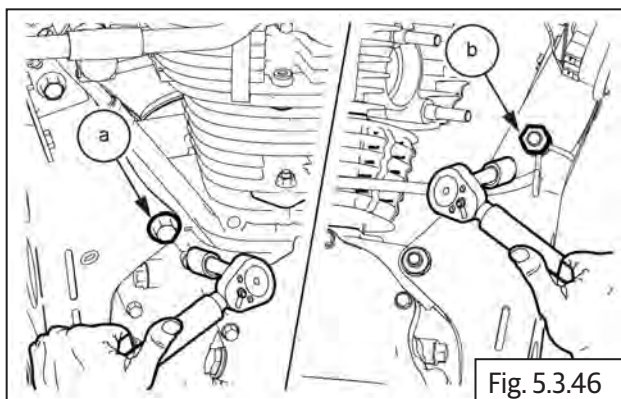

- Loosen and remove Hex flange head bolt **(M10) (a)** along with nut **(M10) (b)** and washers **(c)** from rear lower bottom of engine.

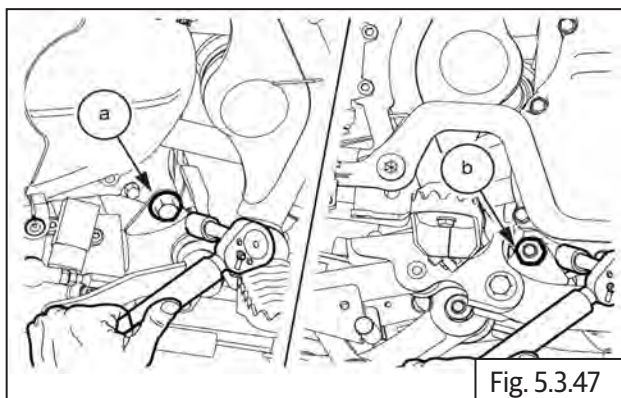

- Loosen and remove Hex flange head bolt **(M10) (a)** along with nut **(M10) (b)** and washers **(c)** from rear upper bottom of engine.

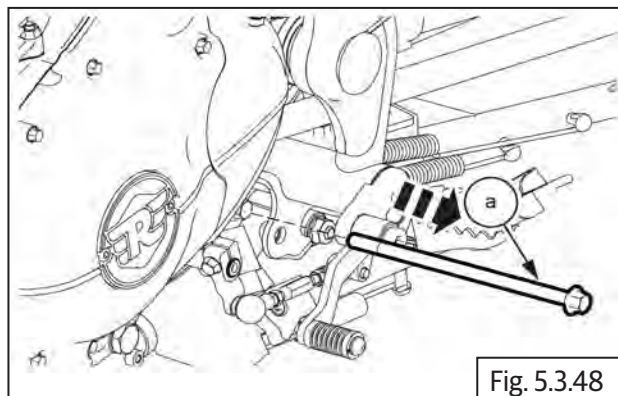

- Gently lower the jack **(a)** and remove engine **(b)**.

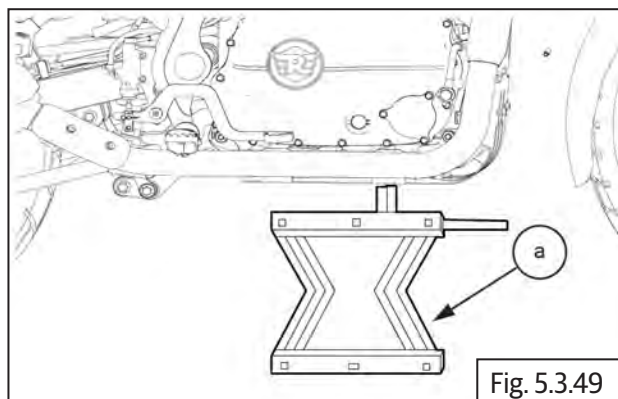

ENGINE DISMANTLING

Engine Dismantling

CONTENTS	PAGE
5.2 Engine Dismantling.....	64
5.2.1. Oil Cooler	64
5.2.2. Drain Plug	64
5.2.3. Oil Filter	65
5.2.4. Cover crankshaft center	66
5.2.5. Throttle Body.....	66
5.2.6. Injector	66
5.2.7. Spark Plugs.....	67
5.2.8. Engine Oil Temperature Sensor	67
5.2.9. Starter Motor	67
5.2.10. Breather Hose	68
5.2.11. Cover RH.....	68
5.2.12. Gear Position Sensor	68
5.2.13. Clutch Actuating Lever Assembly.....	69
5.2.14. Oil Level Window.....	69
5.2.15. Oil Bypass seal	69
5.2.16. Balancer Shaft Bolt.....	70
5.2.17. Crankshaft Nut	70
5.2.18. Oil Jet.....	71
5.2.19. Oil Pump	71
5.2.20. Clutch Assembly	72
5.2.21. Gear Shifter Shaft.....	74
5.2.22. Star Index Stopper.....	75
5.2.23. Star Index.....	76
5.2.24. FD Sprocket Cover	76

Engine Dismantling

CONTENTS	PAGE
5.2.25. FD Sprocket	76
5.2.26. Cylinder Head Cover	77
5.2.27. Auto Chain Tensioner	79
5.2.28. Rocker Arms from Rocker Carriers	80
5.2.29. Center Cover LH	80
5.2.30. Cover LH.....	81
5.2.31. Idler Gear	81
5.2.32. Cam Shaft, Sprocket & Chain.....	81
5.2.33. Stator Assembly.....	83
5.2.34. Magneto Rotor Bolt	83
5.2.35. Starter Clutch from Magneto Rotor.....	84
5.2.36. Cylinder Head	85
5.2.37. Components from Cylinder Head	86
5.2.38. Cylinder Barrel.....	87
5.2.39. Piston.....	88
5.2.40. Crankcase Fasteners	88
5.2.41. Splitting Crankcase.....	88
5.2.42. Balancer Shaft	89
5.2.43. Crankshaft Assembly.....	89
5.2.44. Gear Selector	89
5.2.45. Countershaft.....	90
5.2.46. Driveshaft.....	91

1.2 Engine Dismantling

NOTE

- Ensure the engine is properly clamped on the holding fixture on a worktable.
- Ensure the engine is clean and free of any oil residue/dirt. Clean engine with recommended degrease agents/solvents to remove oil residue/dirt.
- Ensure worktable is clean and atmosphere is dust free.

1.2.1. Oil Cooler

- Place a tray under the engine.
- Loosen and remove 1 No Banjo bolt **(a)** along with 4 Nos. from both RH and LH Crankcase respectively & allow oil to drain.

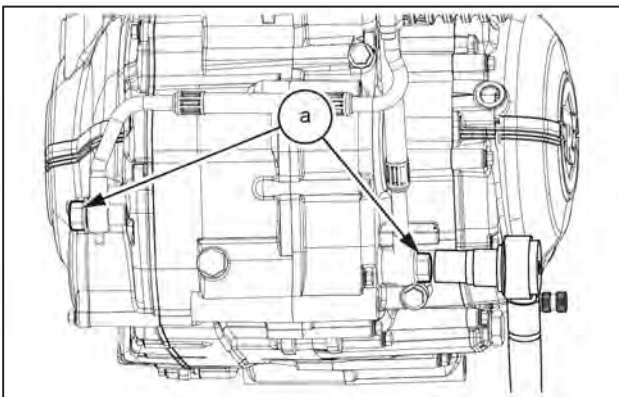

- Remove the oil cooler along with inlet & outlet pipes.

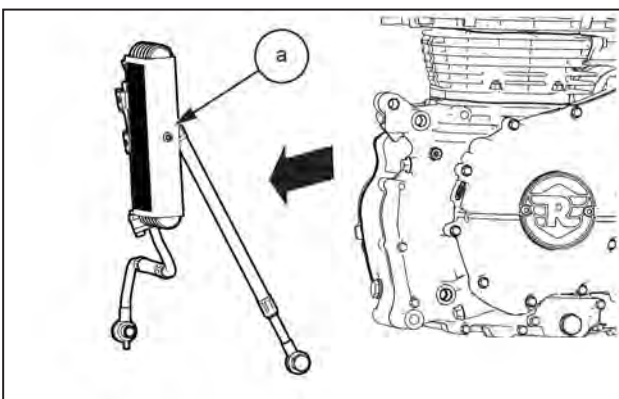

1.2.2. Drain Plug

- Loosen and remove oil filler cap **(a)** from the crankcase top on the RH side.
- Use an adjustable plier with soft jaws to unscrew filler cap if necessary.

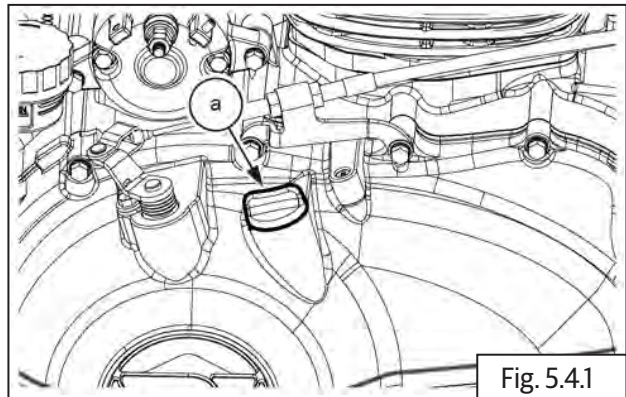

Nose Plier

- Loosen and remove drain bolt **(a)** along with washer **(b)**.

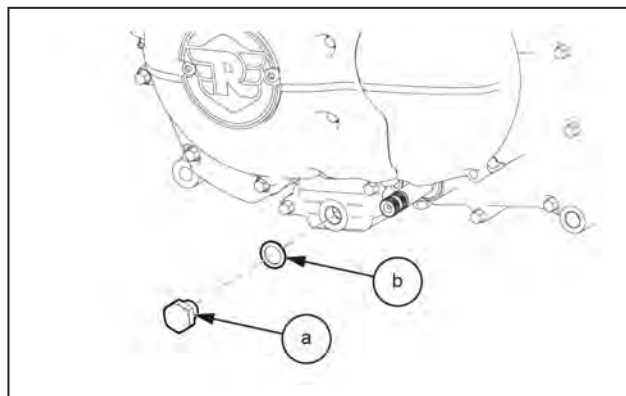

- Remove the oil strainer cap 2 bolts **(a) (M6)**.

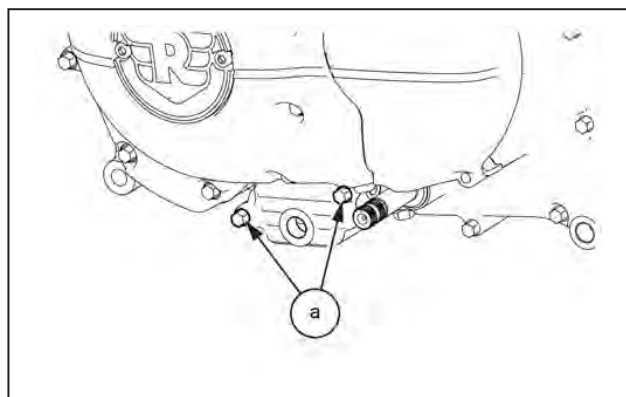

8 mm Socket with Ratchet

- Remove the oil strainer cap **(a)** along with O-Ring **(b)**.

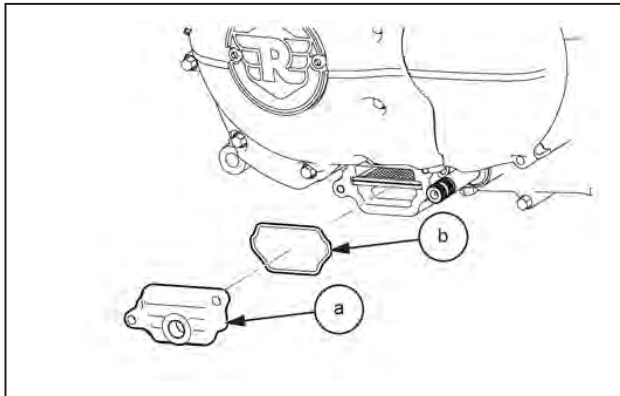

- Gently remove the oil strainer **(a)**.

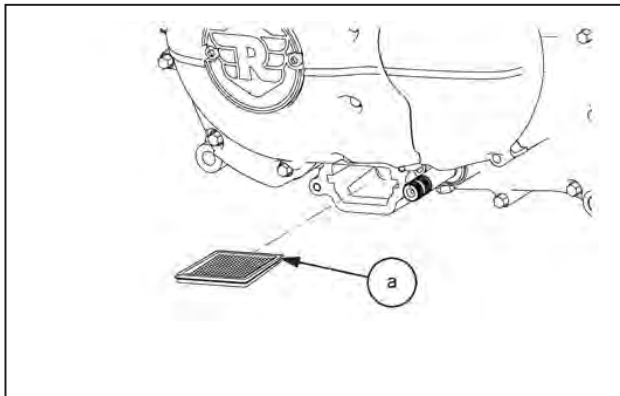

⚠ WARNING

Do not spill oil . Collect used oil in a separate container and dispose it through authorized disposal agencies in your locality. Avoid skin OR body contact with the oil. Promptly wash affected area with soap and water.

NOTE

- Ensure the engine oil is drained completely.
- After draining the oil suitably cover the oil filler cap hole to prevent debris.

5.2.3 Oil Filter

- Remove 1 long Hex flange bolt **(a)** from the bottom of oil filter cover.
- Remove 2 Hex flange bolts **(M6) (b)** from the top of the oil filter cover.

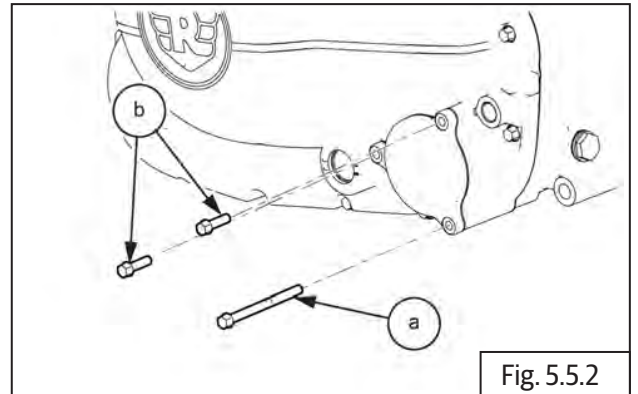

8 mm socket with Ratchet

- Gently remove oil filter cover **(a)** along with gasket **(b)**.

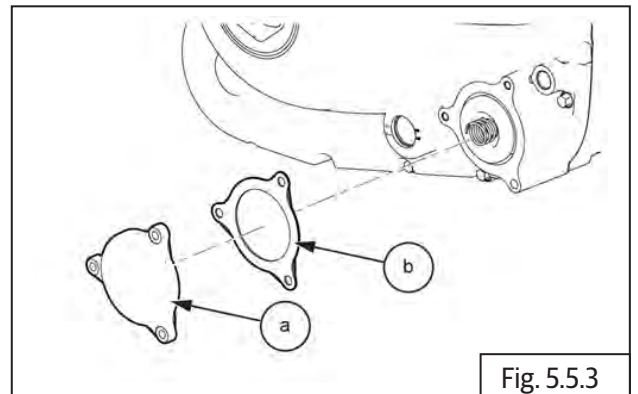

- Gently shake and remove the oil filter **(a)** from cover RH

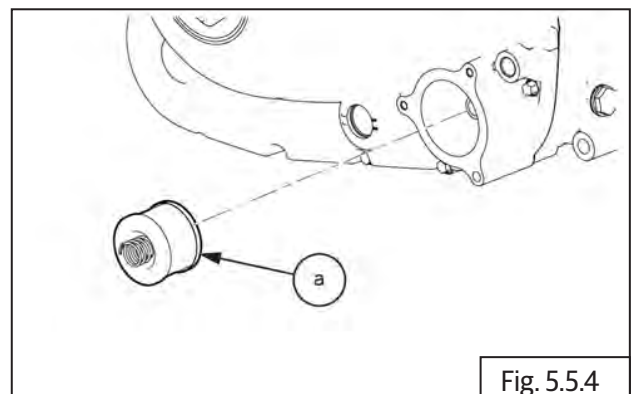

5.2.4 Cover crankshaft center

- Remove the 2 Nos. allen bolts **(a)** along with the crankshaft center cover **(b)** and O-ring **(c)**.

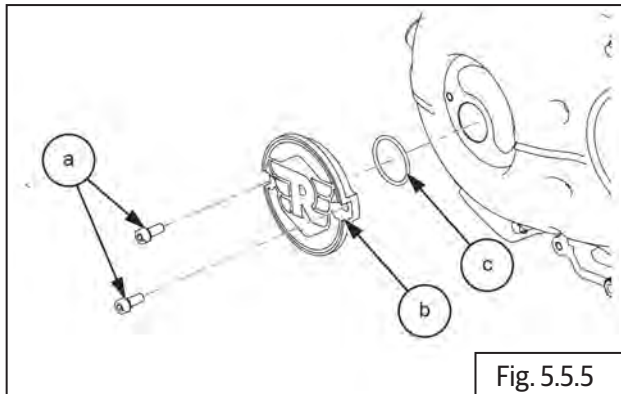

5.2.5 Throttle Body

For EURO IV Model

- Loosen and remove 1 No **(M5)** **(a)** allen bolt holding the throttle body.
- Gently pull out the throttle body **(b)** along with rubber manifold.

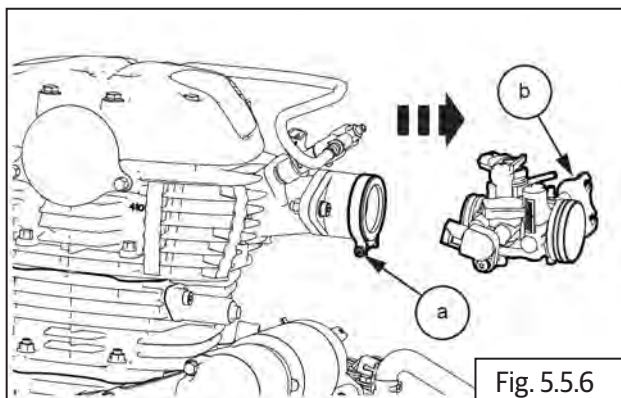

4 mm Allen socket with Ratchet

For EURO V Model

- Loosen and remove 1 No **(M5)** **(a)** allen bolt from the clamp **(c)**.
- Gently pull out the throttle body **(b)** along with rubber manifold.

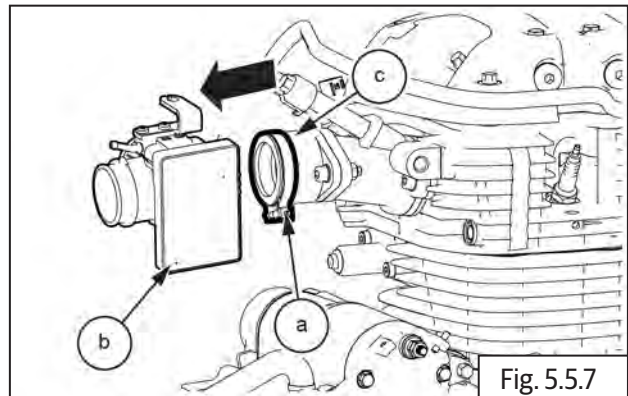

4 mm Allen socket with Ratchet

5.2.6 Injector

- Remove 1 No **(M6)** injector mounting bolts **(a)**.

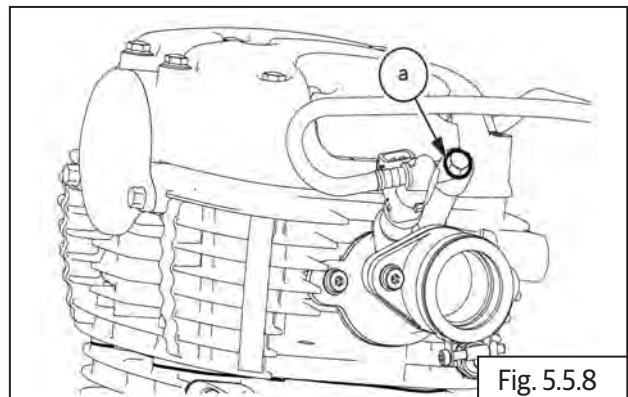

10 mm socket with Ratchet

- Pull out the injector to remove.

⚠ CAUTION

- Store the injector in a clean and dry place. Make sure that the injector is not damaged.
- Place the injector in a plastic bag to avoid dust entry.

5.2.7 Spark Plugs

⚠ CAUTION

Before removing the spark plugs, blow away any dirt accumulated in the spark plug area with compressed air to prevent it from falling into cylinder head.

- Loosen and remove spark plug **(a)** from cylinder head.

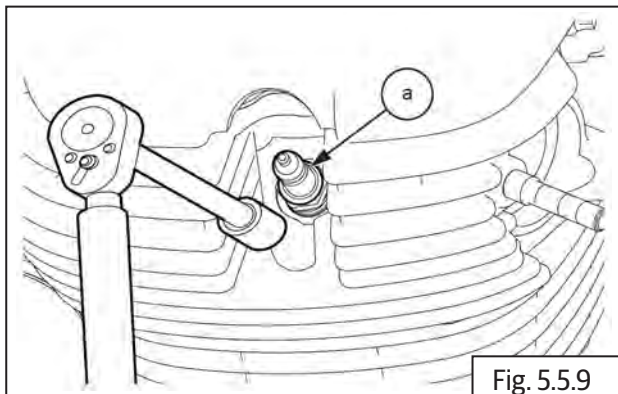

16 mm Deep Socket with Ratchet

- Remove the spark plug and washer gently from its position.

5.2.8 Engine Oil Temperature Sensor

- Loosen and remove the engine oil temperature sensor **(a)** from its mounting.

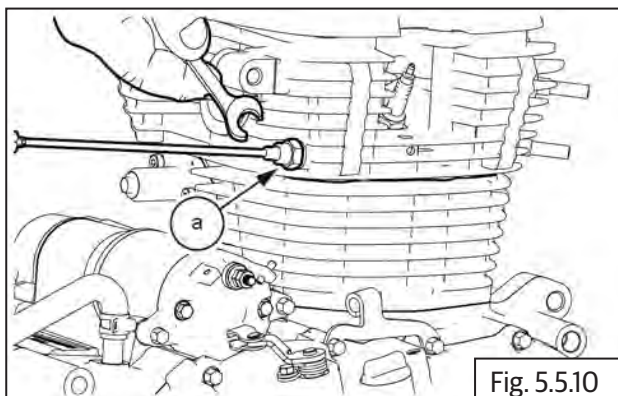

18mm Open End Spanner

- Gently pull out the engine oil temperature sensor along with the O-Ring

5.2.9 Starter Motor

- Loosen and remove 2 Nos. allen bolts **(M6)** **(a)** and remove body ground winglet.

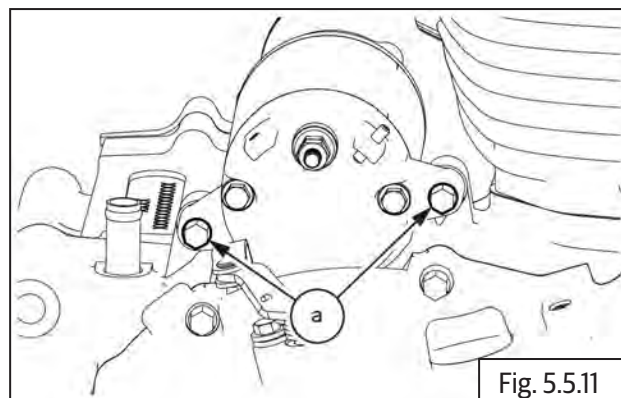

5 mm Allenkey with Ratchet

- Gently remove the starter motor **(a)** from engine.

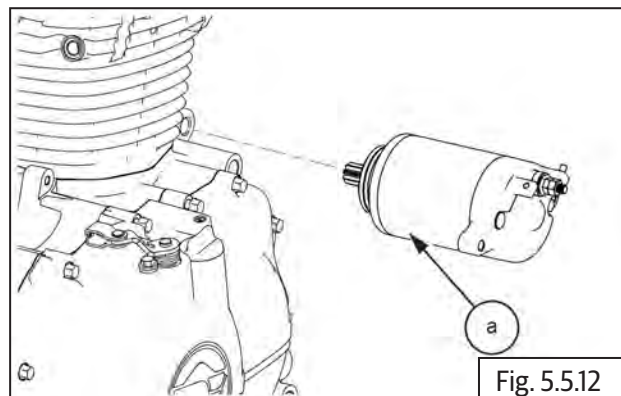

NOTE

- DO NOT** tap on the starter motor while removing it. Tapping may damage the internal components.

5.2.10 Breather Hose

- Remove the Circlip **(a)** on the breather **(b)** and gently pull it to remove.

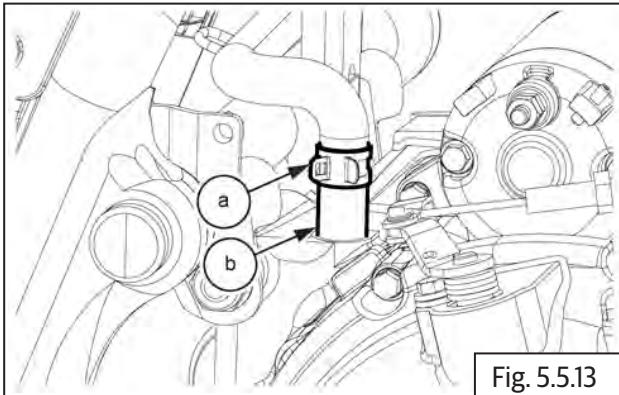

Nose Plier

5.2.11 Cover RH

- Remove 18 Nos. Bolts **(M6)** **(a)** in the sequence mentioned below to remove cover RH **(b)**.

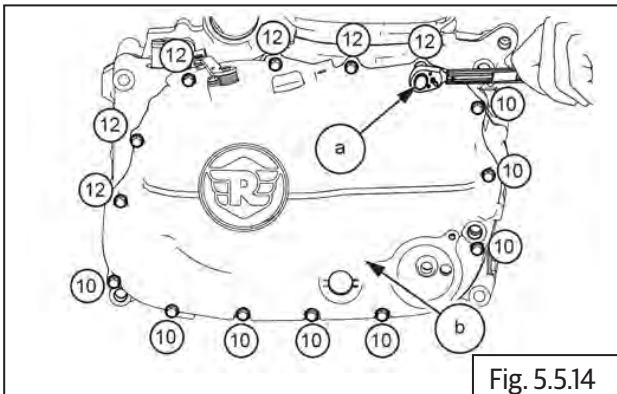

5 mm Allen socket with Ratchet

- Adjust the clutch actuating arm to and fro with hand to remove the cover RH **(a)** along with gasket **(b)**.

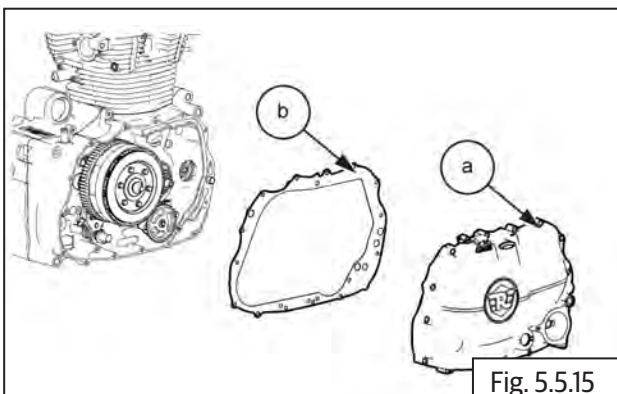

⚠ CAUTION

Do not use a sharp tool to scrap the gasket material from the joint faces.

If required scrap only with a soft and blunt tool.

5.2.12 Gear Position Sensor

- Remove 2 Nos. Hex bolts **(M5)** **(a)** mounted on gear position sensor.

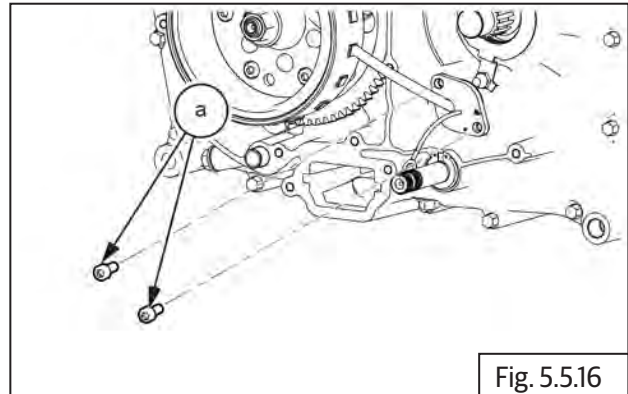

8 mm Socket with Ratchet

- Gently tap Gear Position Sensor **(a)** and remove along with O-ring **(b)** **(for EURO IV Model)**.

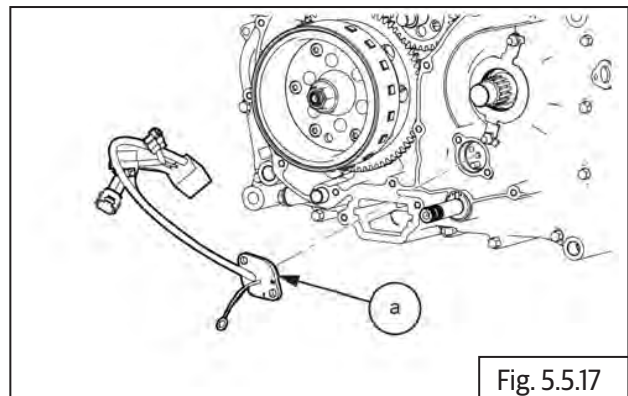

- Gently tap Gear Position Sensor **(a)** and remove along with O-ring **(b)** **(for EURO V Model)**.

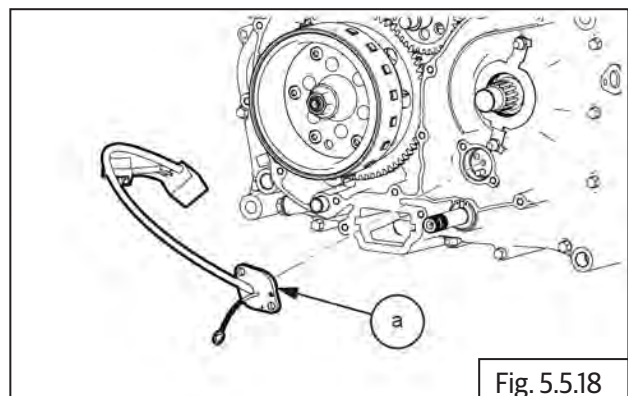

5.2.13 Clutch Actuating Lever Assembly

- Loosen and remove the hex bolt (a) from clutch actuating lever assembly.

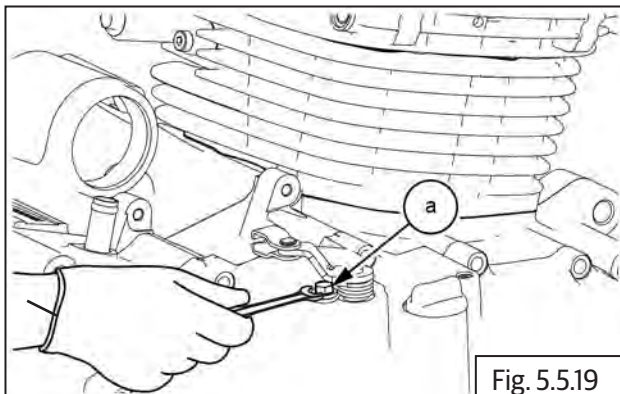

	10 mm Socket with Ratchet
--	---------------------------

- Remove clutch actuating lever and spring from clutch shaft on RH cover.

NOTE
<ul style="list-style-type: none"> Use a suitable wedge to slightly expand the slot in the clutch actuating arm and gently lift from the shaft.

5.2.14 Oil Level Window

- Remove the circlip (a) on the oil level window inside clutch cover.

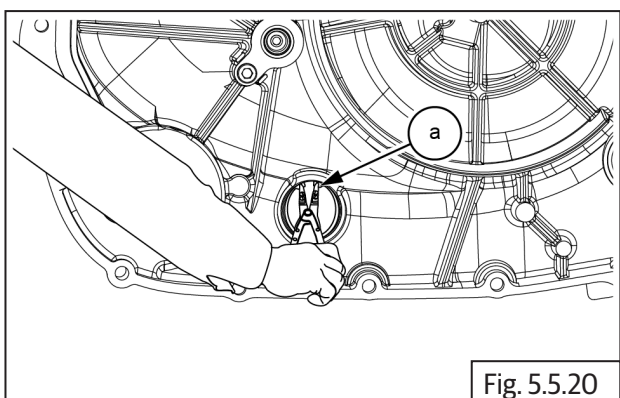

	Circlip plier
--	---------------

- Gently press oil window (a) from outer side to remove from clutch cover.

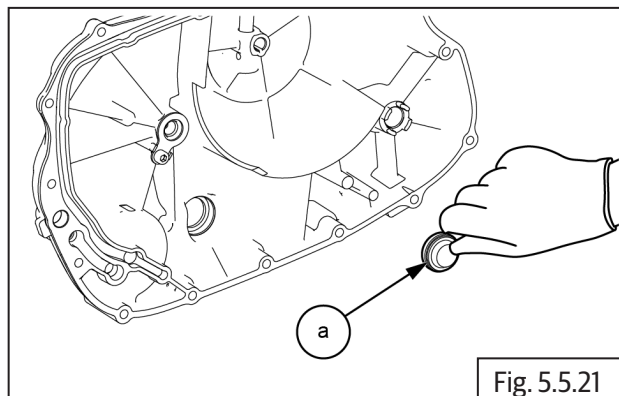

5.2.15 Oil Bypass seal

- Loosen and remove 1 Nos (M6) allen bolts (a) along with the retainer plate (b).

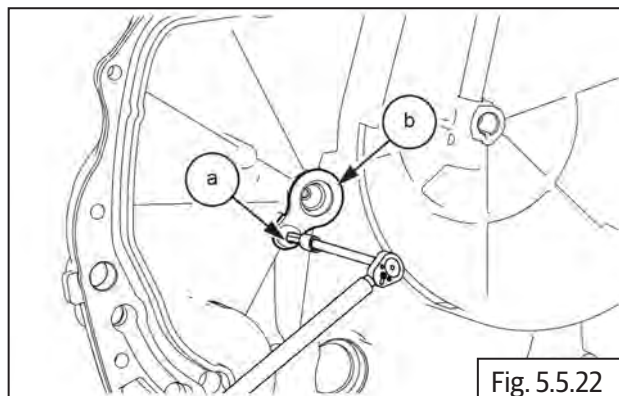

	5mm Allen Socket with Ratchet
--	-------------------------------

- Gently remove the oil seal (a) from the cover RH using a screw driver.

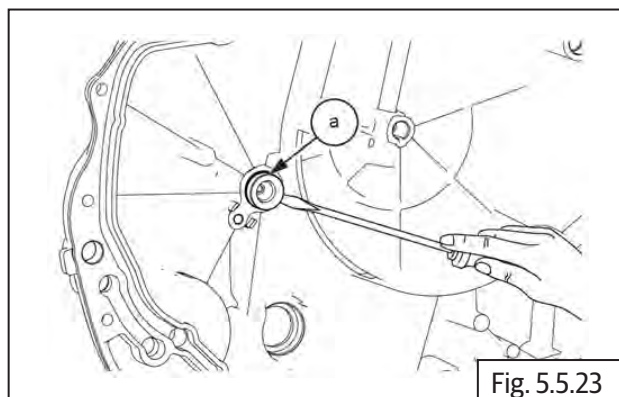

	Screw Driver
--	--------------

5.2.16 Balancer Shaft Bolt

⚠ CAUTION

- Refer section 5.2.30 to remove cover LH and to loosen magneto rotor bolt.
 - It is not possible to remove the magneto rotor once the clutch assembly is removed.
 - Do not dismantle the magneto rotor completely before removing the cylinder head assembly.
- Locate the special tool (a) between clutch housing and crank gear.

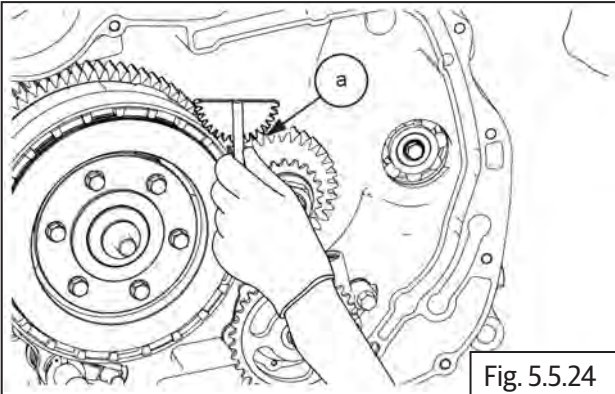

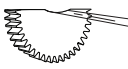
	Part No: ST30922/A
	Part Name: Crank Lock Tool

- Remove balancer shaft bolt **M10 (a)** along with two washers.

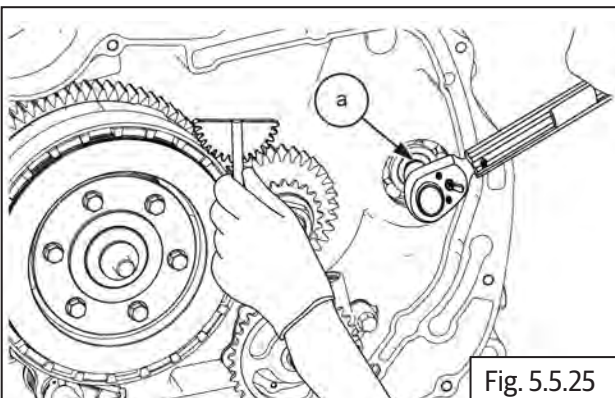

	14 mm Socket with Ratchet
---	---------------------------

5.2.17 Crankshaft Nut

⚠ CAUTION

Crank nut is a left hand thread. Wrong rotation may damage the threads.

- Locate the special tool (a) between clutch housing and crank gear.

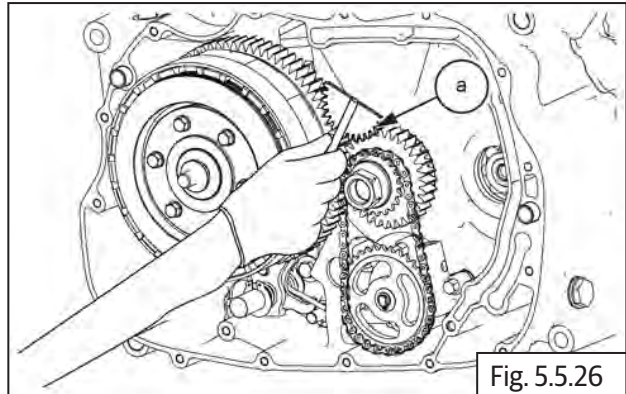

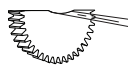
	Part No: ST30922/A
	Part Name: Crank Lock Tool

- Remove crankshaft nut (a) along with two washers (b) and oil pump drive sprocket (c).

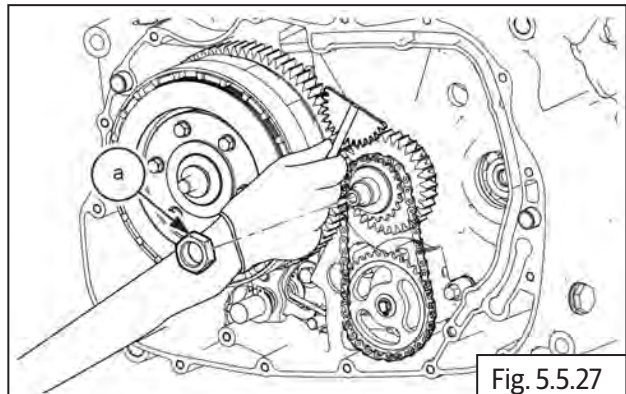

	24 mm Socket with Ratchet
---	---------------------------

- Remove oil pump chain **(a)** from the sprocket.

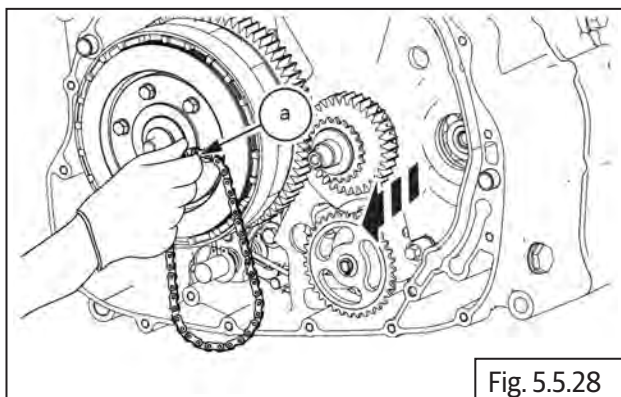

Fig. 5.5.28

- Remove washer **(a)** and sprocket **(b)** from the crankshaft gear.

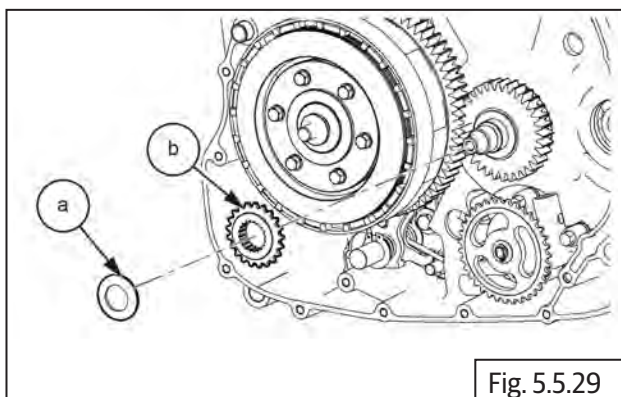

Fig. 5.5.29

- Remove the washet **(a)** and crankshaft gear **(b)**.

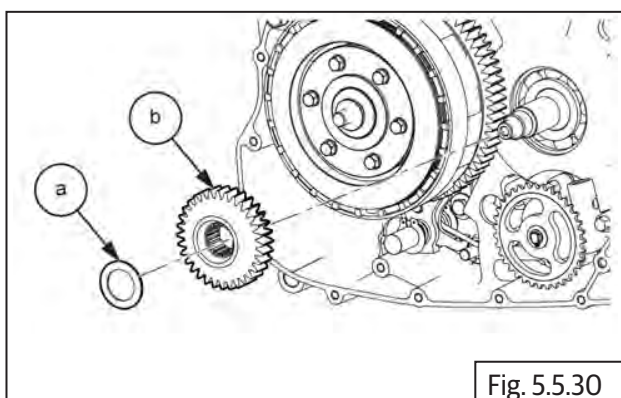

Fig. 5.5.30

5.2.18 Oil Jet

NOTE

- Ensure gearbox is in neutral condition
- Loosen and remove oil jet **(a)** from the crankcase.

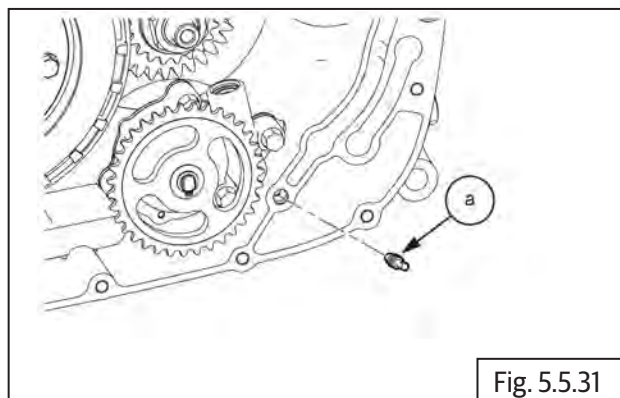

Fig. 5.5.31



Nose plier

5.2.19 Oil Pump

- Loosen and remove Hex flange bolt **(M6) (a)** on oil pump sprocket along with washer.

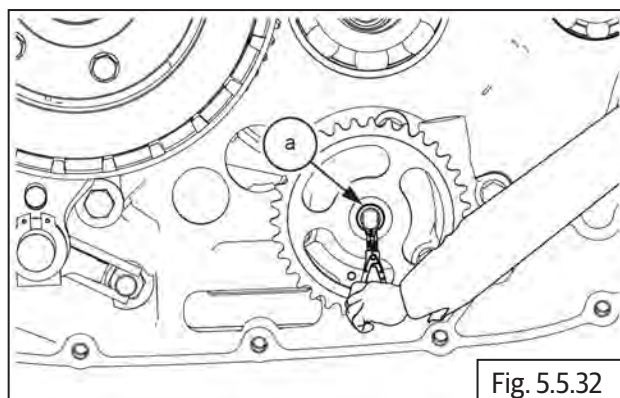

Fig. 5.5.32



10 mm Socket with Ratchet

- Remove oil pump sprocket **(b)** along with the washers **(a)** and **(c)**.

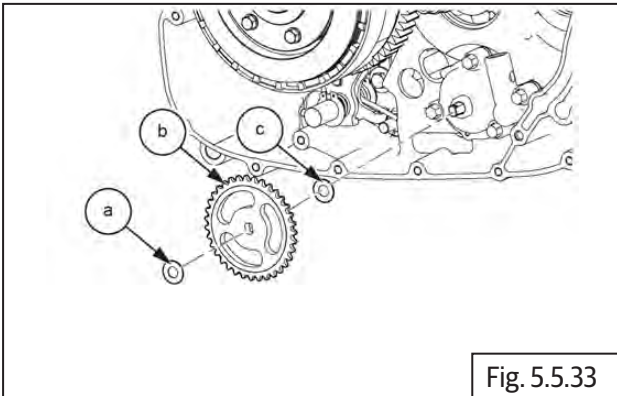

Fig. 5.5.33

- Remove 4 Nos. Hex flange head bolts **(M6)** **(a)** in crisscross pattern.

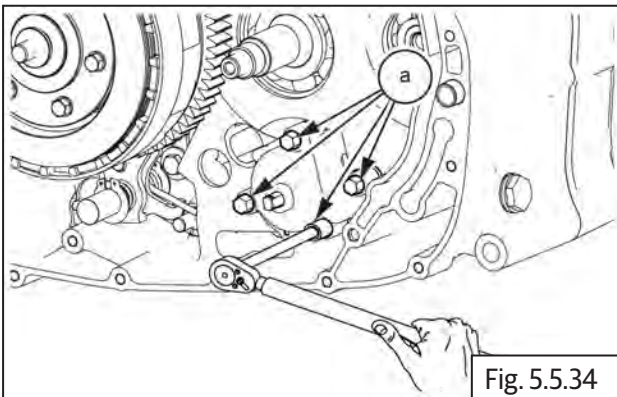

Fig. 5.5.34



8 mm Socket with Ratchet

- Remove oil pump **(a)** along with the metal gasket **(b)**.

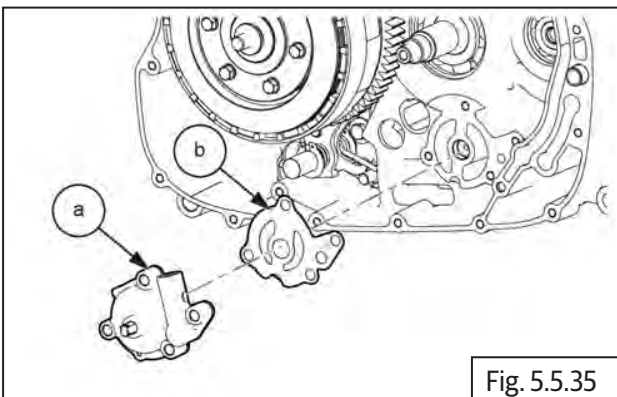

Fig. 5.5.35

NOTE

- The oil pump does not have any serviceable parts, hence as to be replaced only as a complete assembly.

5.2.20 Clutch Assembly

CAUTION

Ensure gearbox in neutral position.

- Remove the bearing **(a)** from the clutch housing.

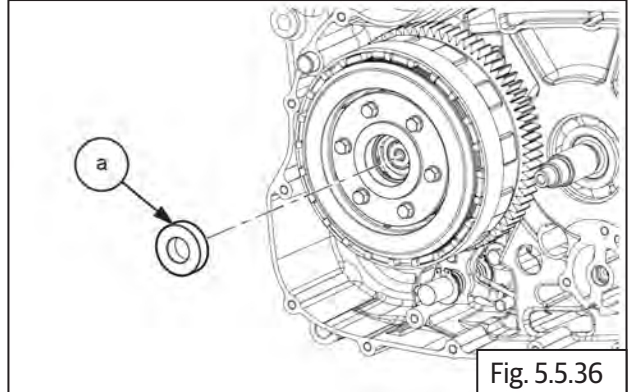

Fig. 5.5.36

- Loosen the U-nut **(a)** from the clutch assembly by locking the counter shaft using special tool.

CAUTION

Hex "U" nut is a left hand thread. Wrong rotation may damage the threads.

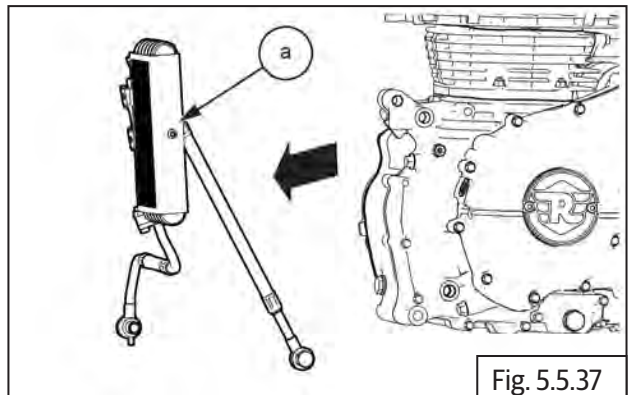
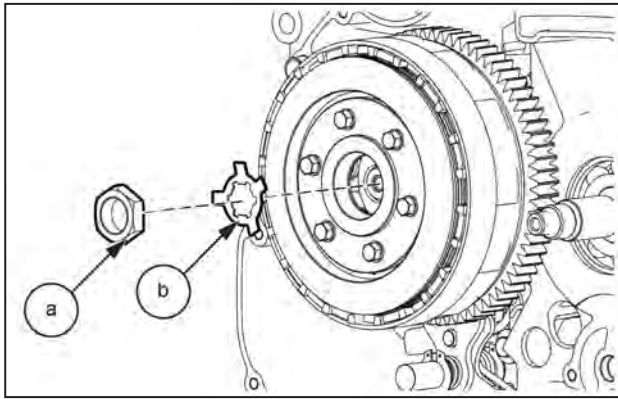

Fig. 5.5.37



24 mm Socket with Ratchet

- Remove U-nut **(a)** and tab washer **(b)** from counter shaft.



- Remove the clutch assembly **(a)** from the counter shaft.

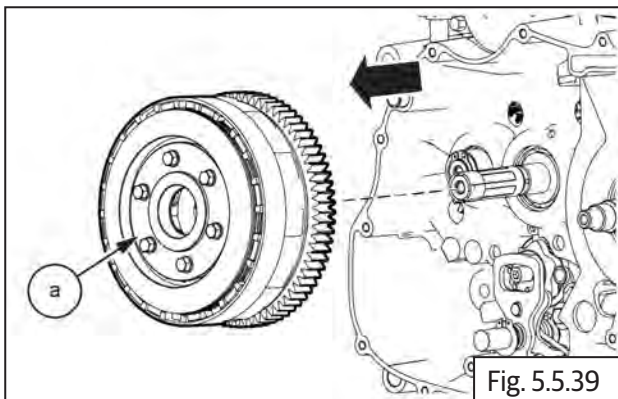

- Remove 2 Nos. Hex bolts along with washers from clutch assembly.

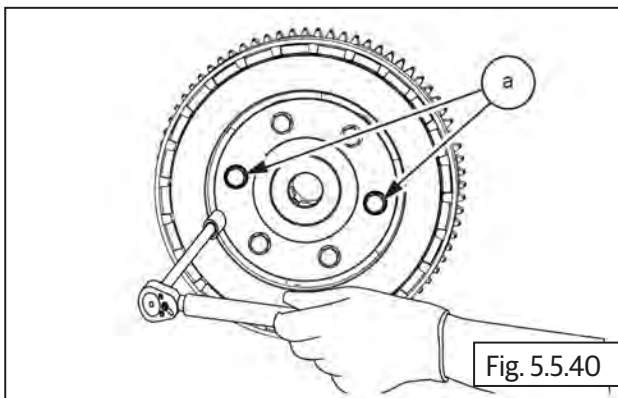

10 mm Socket with Ratchet

- Install the special tool **(b)** using 2 Nos. Hex bolts **(a)**.

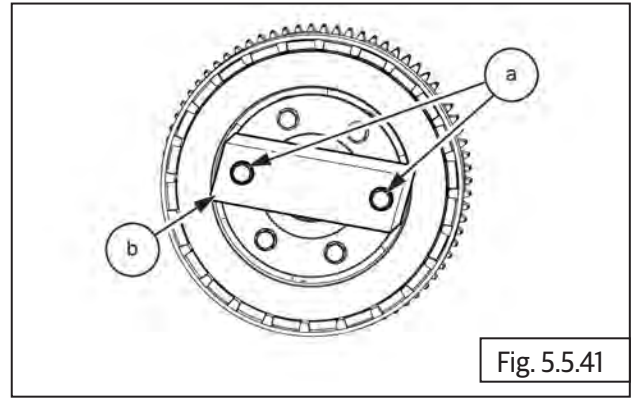

- Remove 4 Nos. Hex bolts **(a)** from the clutch assembly.

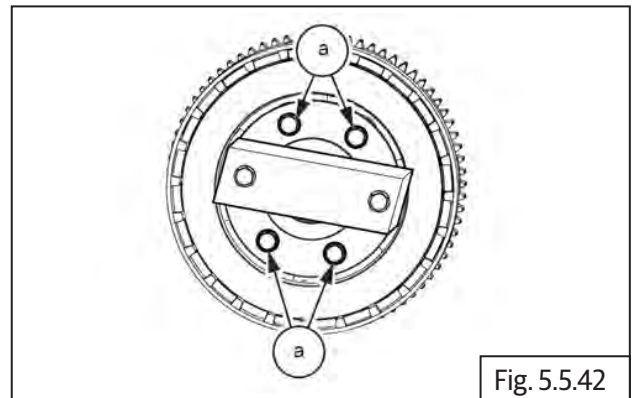

- Loosen and remove uniformly 2 Nos. Hex bolts **(a)** and remove the special tool **(b)**.

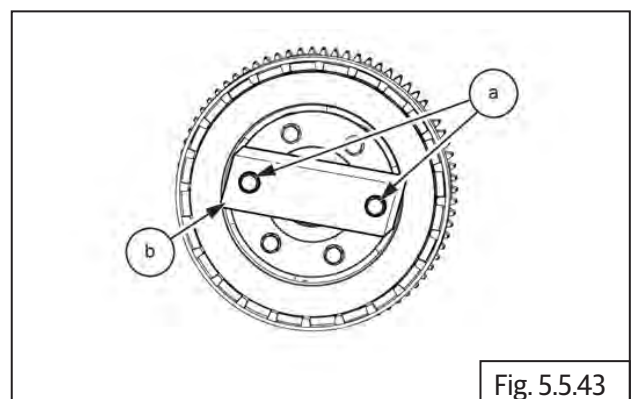

- Remove the pressure plate **(a)** slowly from the springs.

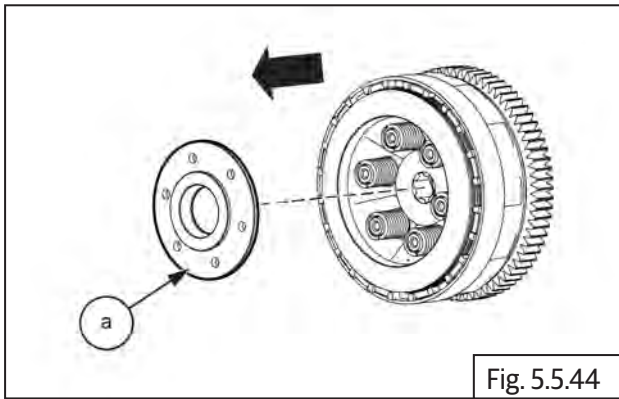

- Remove the thrust plate **(a)** and steel plate **(b)** from the clutch housing.

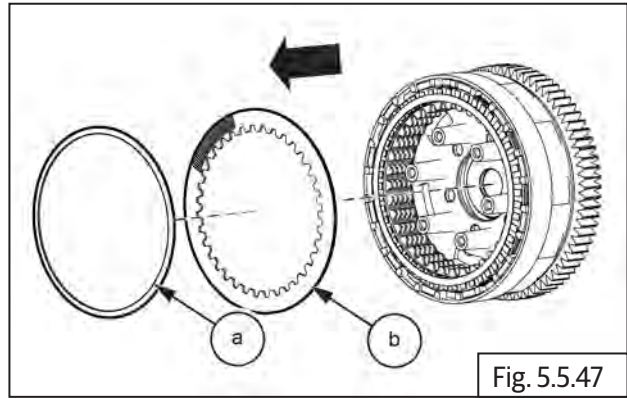

- Remove six springs **(a)** from the clutch.

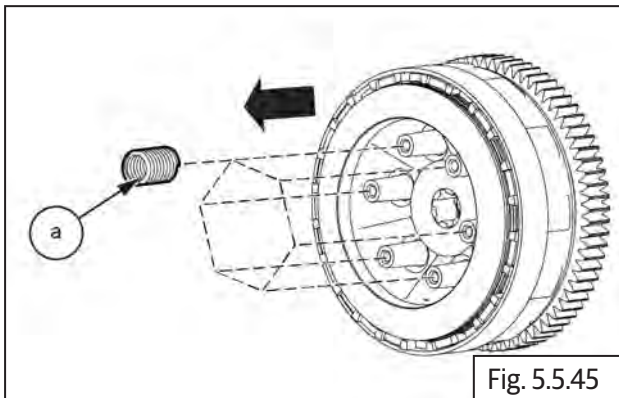

- Remove the clutch housing **(a)** from the crankshaft.

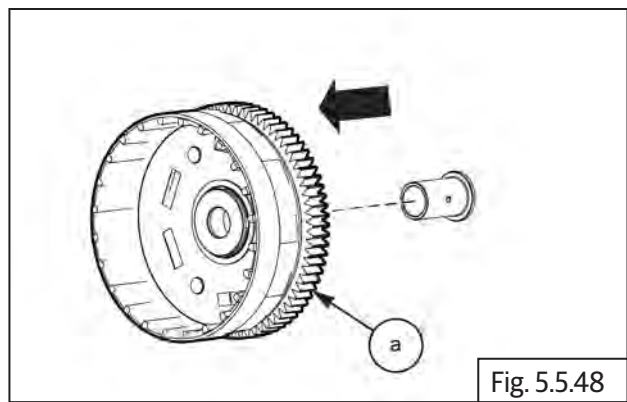

- Remove the clutch bell **(a)** from clutch housing **(b)**.

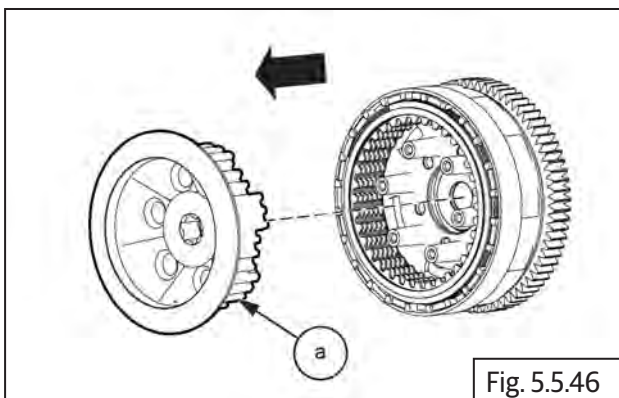

5.2.21 Gear Shifter Shaft

- Remove the circlip **(a)** along with washer **(b)** from shifter shaft from engine LH side.

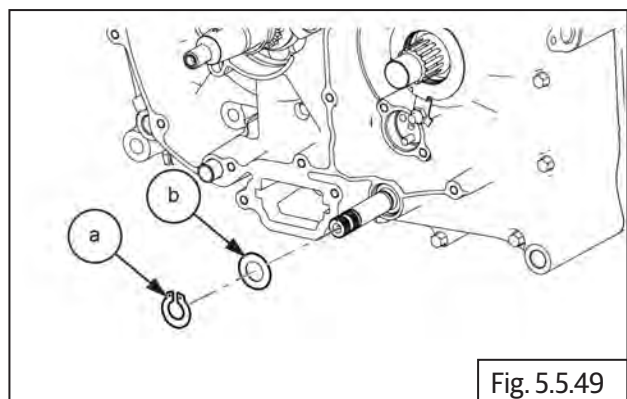

Circlip plier

- Gently pull out shifter shaft assembly **(a)** from engine RH side.

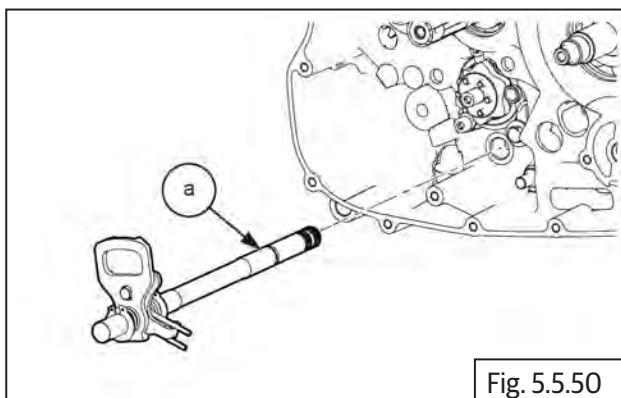

- Remove circlip **(a)**, washer **(b)** from longer end of shifter shaft **(c)**.

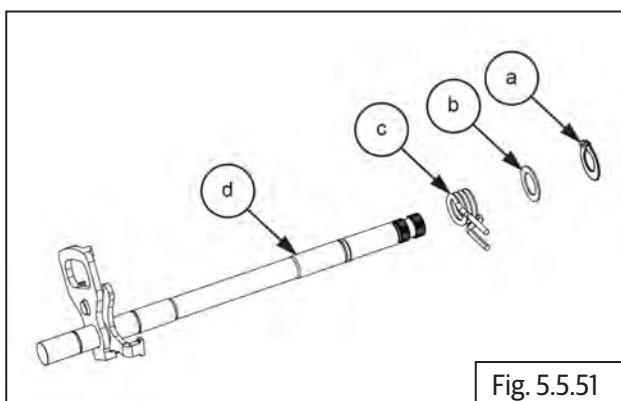

- Expand spring legs and pull out spring **(a)** from shorter end of shifter shaft **(b)**.

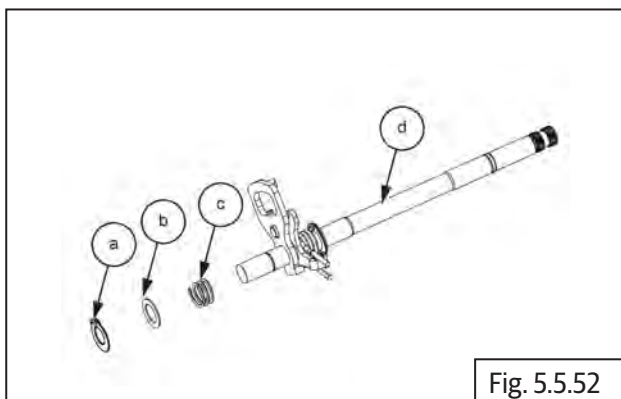

5.2.22 Star Index Stopper

⚠ CAUTION

Spring loaded bolt. Support stopper while removing bolt.

- Loosen and remove Hex head bolt **(M6)** **(a)** from lower crankcase (RH) (clutch side).
- Remove stopper along with spring and washer.

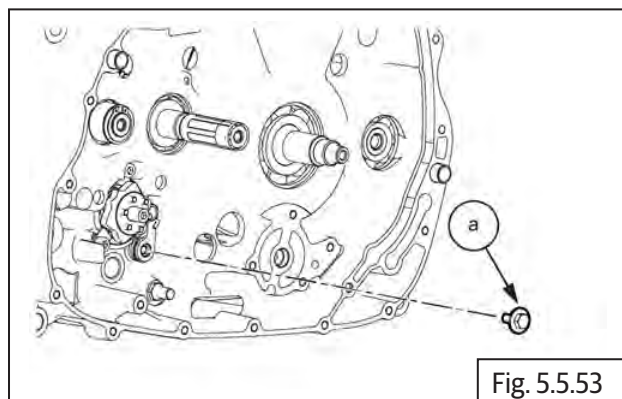

10 mm Socket with Ratchet

- Remove stopper **(b)** along with bolt **(a)** washer **(c)** and spring **(d)**.

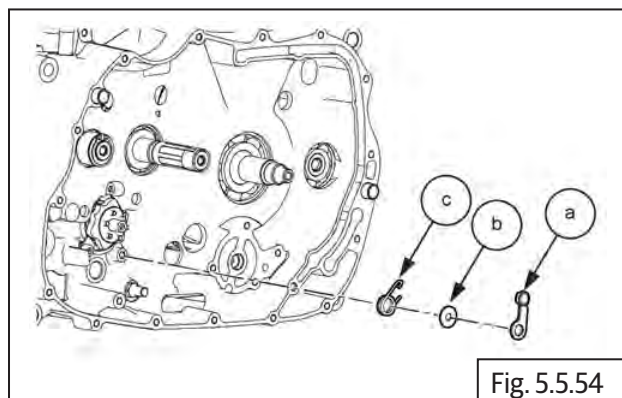

5.2.23 Star Index

- Loosen and remove Hex socket head stepped bolt **(M6) (a)** on star index.

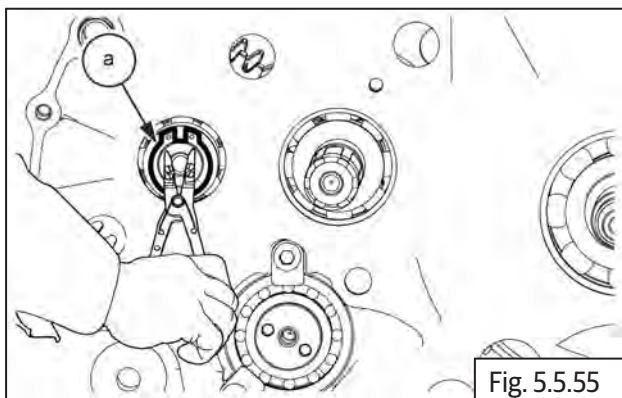

5 mm Allen socket with Ratchet

- Gently remove the transmission jet **(a)** from the case.

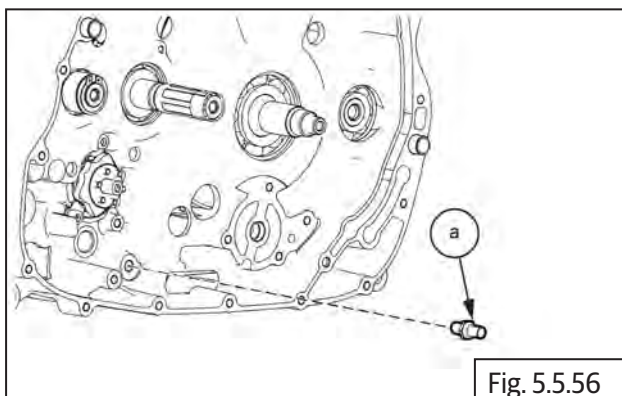

- Gently remove star index **(a)** along with 2 Nos pins.

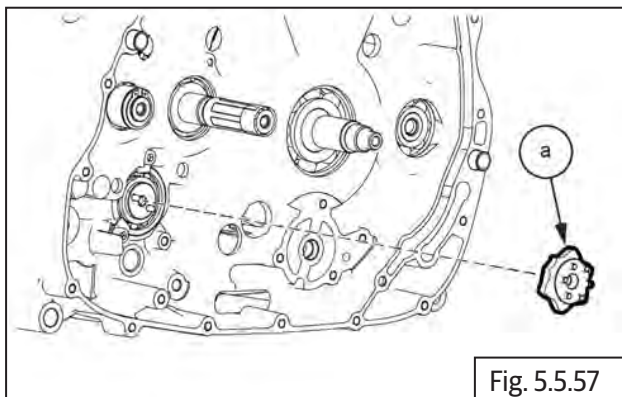

5.2.24 FD Sprocket cover

- Remove 2 Nos. hex bolt **(M6) (a)** from the FD sprocket cover.

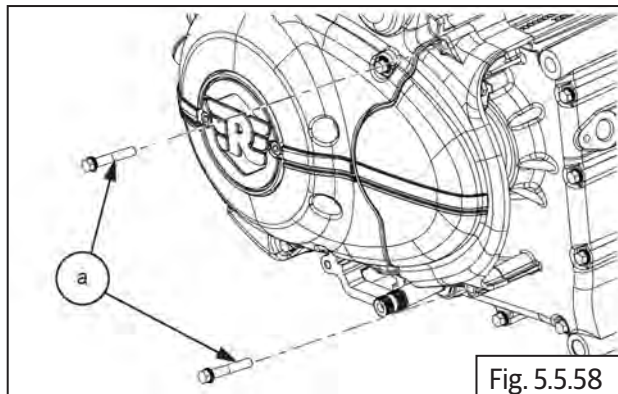

- Gently remove the FD sprocket cover **(a)**.

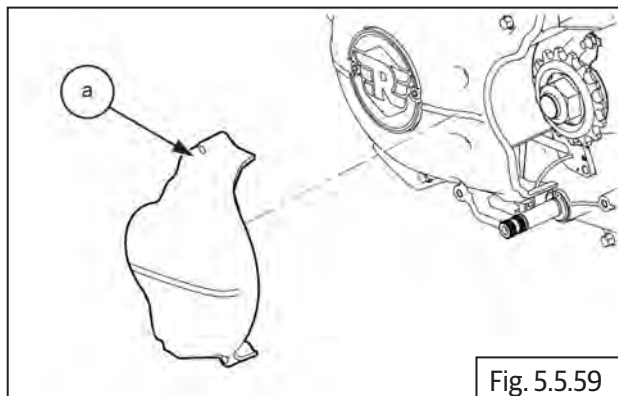

5.2.25 FD Sprocket

- Unlock and release washer holder **(a)**.

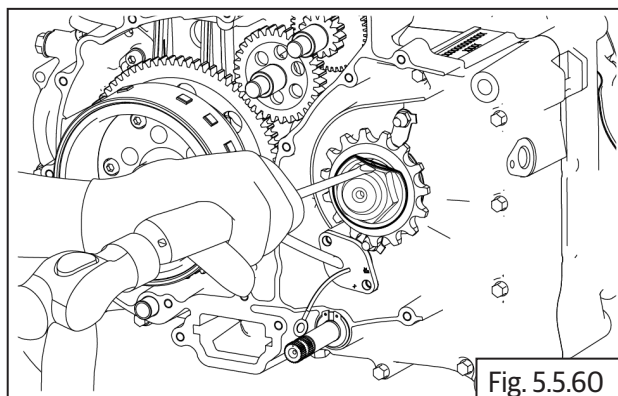

Chisel and Hammer

- Hold FD sprocket using special tool **(a)** and loosen "U" nut **(M20)**.

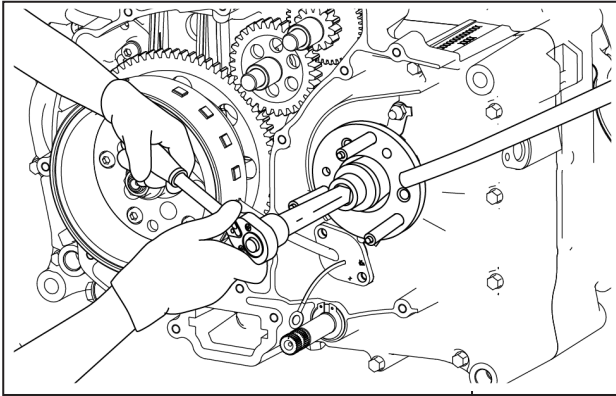

	SPL
	Part No: ST-27534-2
Part Name: FD sprocket holder	

	30 mm Socket with Ratchet
--	---------------------------

- Remove lock tab washer **(a)** from shaft.

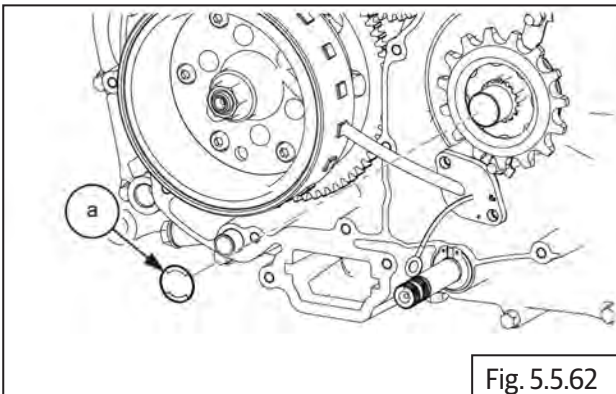

Fig. 5.5.62

- Remove FD sprocket **(a)** from drive shaft.

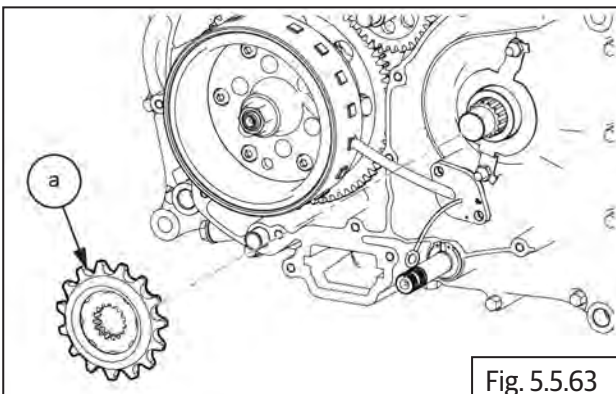

Fig. 5.5.63

- Remove spacer **(a)** and O-ring **(b)** from drive shaft

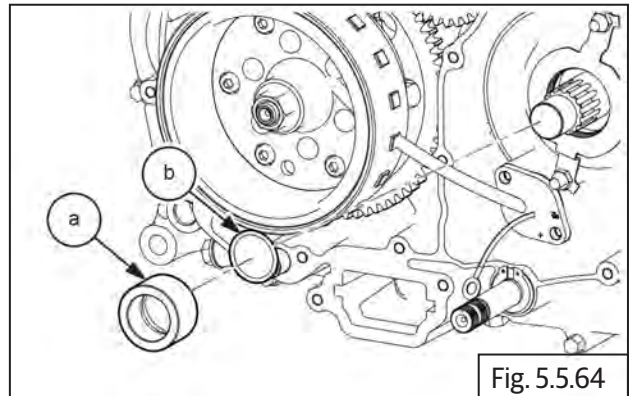

Fig. 5.5.64

5.2.26 Cylinder Head Cover

- Loosen and remove 2 Nos. Hex flange head bolts **(M6)** **(a)** along with rubber seals and washers from LH side.

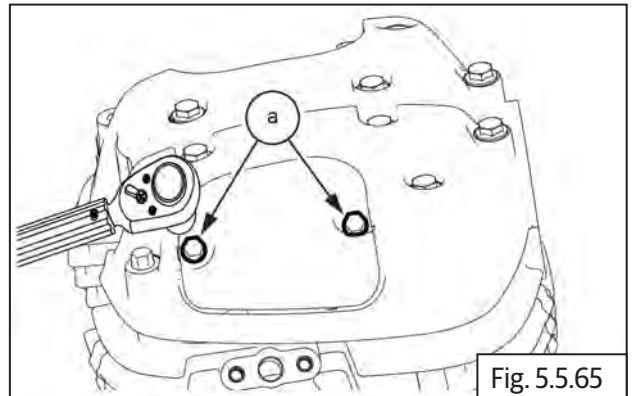

Fig. 5.5.65

	10 mm Socket with Ratchet
--	---------------------------

- Remove the valve cover **(a)** along with the O-ring **(b)**.

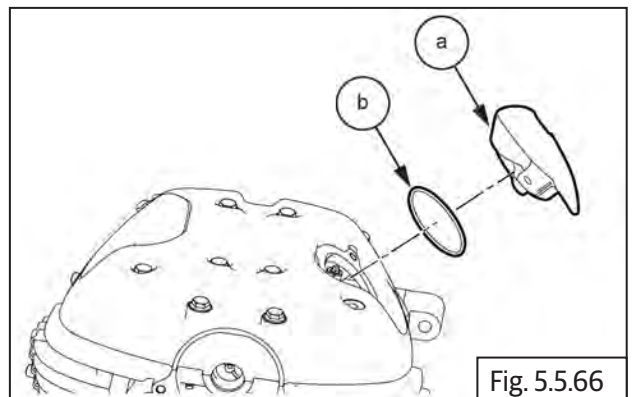

Fig. 5.5.66

- Loosen and remove 2 Nos. Hex flange head bolts **(M6) (a)** along with rubber seals and washers from RH side.

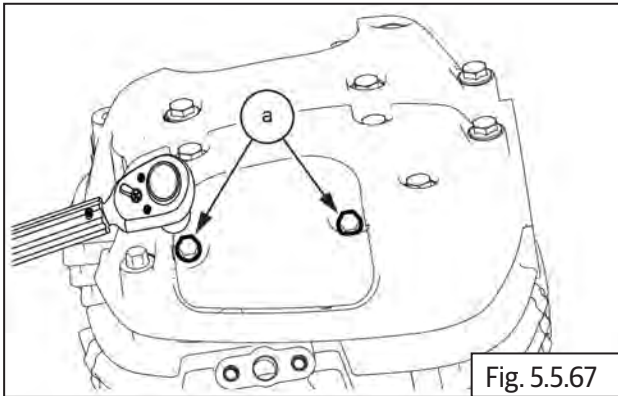

Fig. 5.5.67



10 mm Socket with Ratchet

- Remove the valve cover **(a)** along with the O-ring **(b)**.

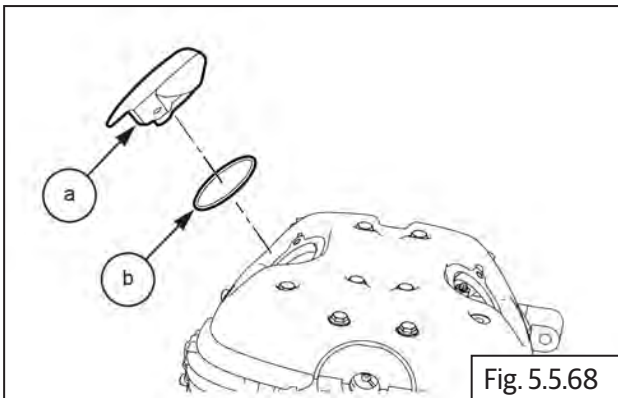

Fig. 5.5.68

- Loosen and remove the 4 Nos .hex length bolts **(M6) (a)** from LH side.

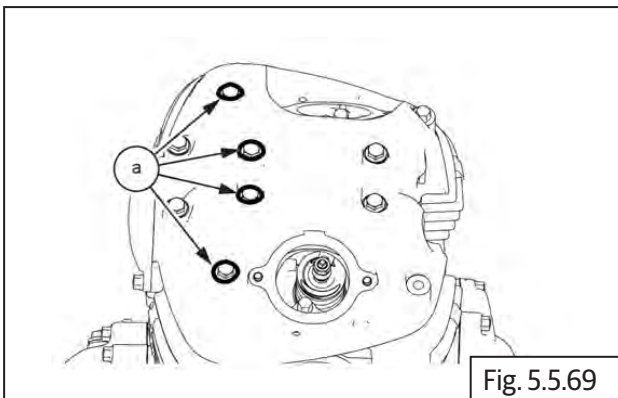

Fig. 5.5.69

- Loosen and remove 2 Nos .hex bolts **(M6) (a)** from LH side.

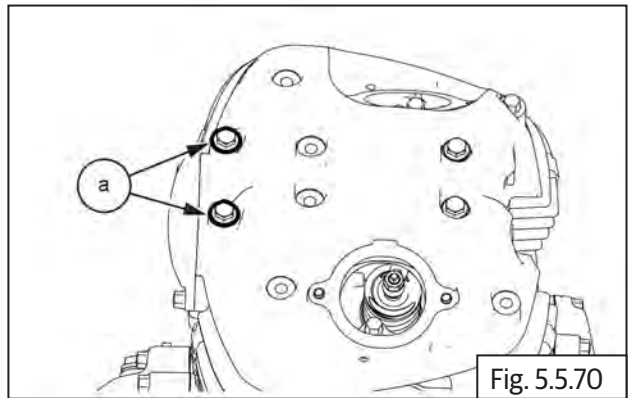

Fig. 5.5.70

- Loosen and remove 2 Nos .hex bolts **(M6) (a)** from RH side.

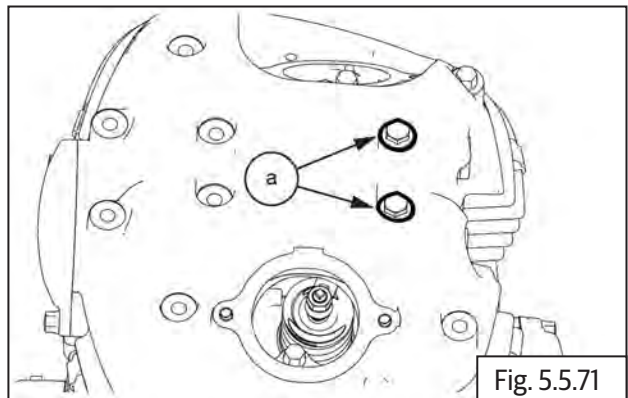

Fig. 5.5.71

- Loosen and remove 2 Nos .hex bolts **(M6) (a)** from RH side.

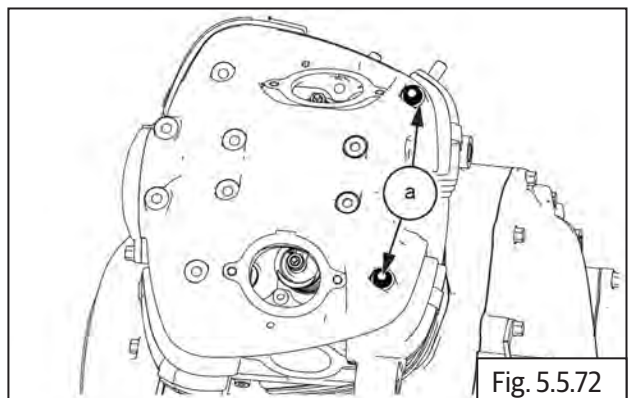
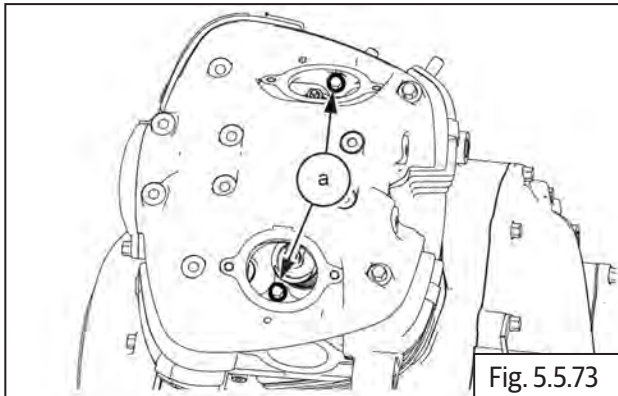
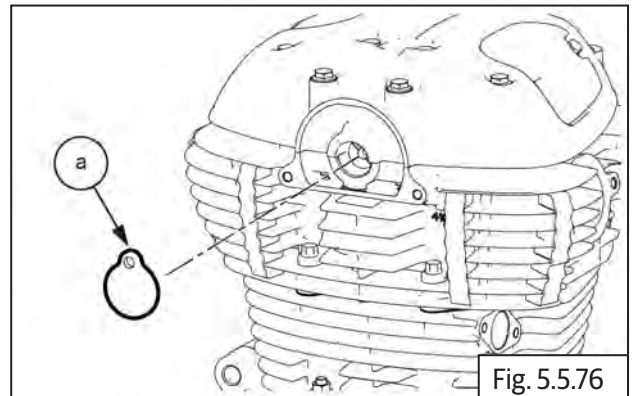

Fig. 5.5.72

- Remove the 3 Nos. hex bolts **(a)** from the inlet and exhaust valves



- Rotate the cover clockwise and remove the cover **(a)**.



- Loosen and remove 2 Nos. allen head bolts **(M4)** **(a)**.

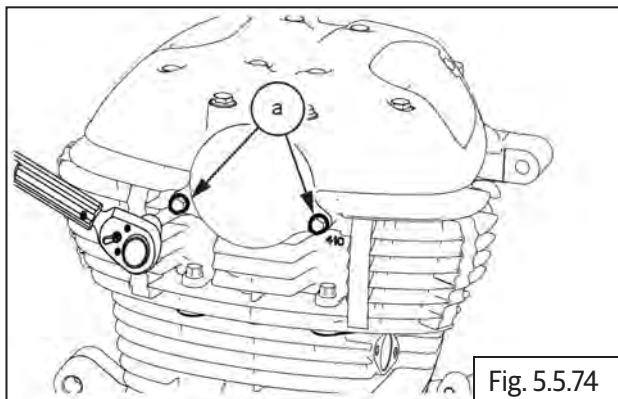

- Gently remove the cover **(a)**.

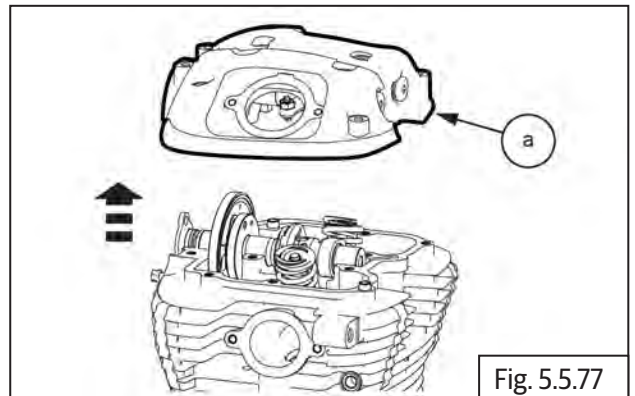

5.2.27 Auto Chain Tensioner



- Remove 1 No. Hex bolt **(a)** from the timing adjuster cover.

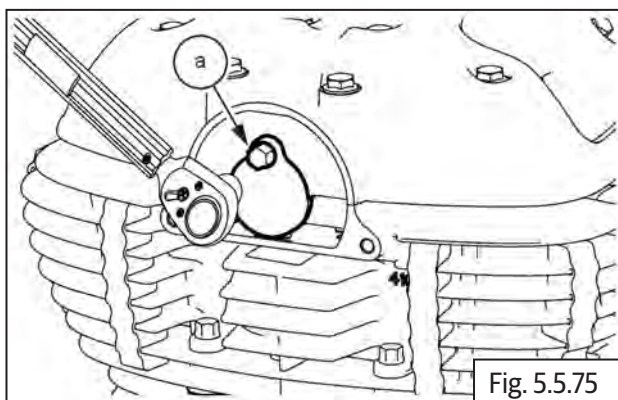

- Loosen and remove center Hex flange bolt **(a)** from chain tensioner.

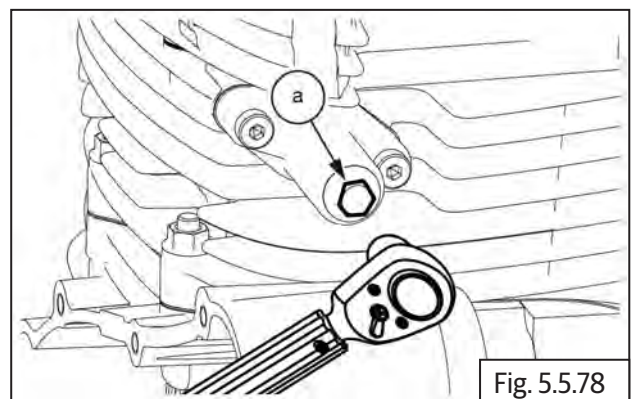

- Loosen and remove 2 Nos. Allen bolts **(M6)** **(a)** from cylinder barrel **(b)**.

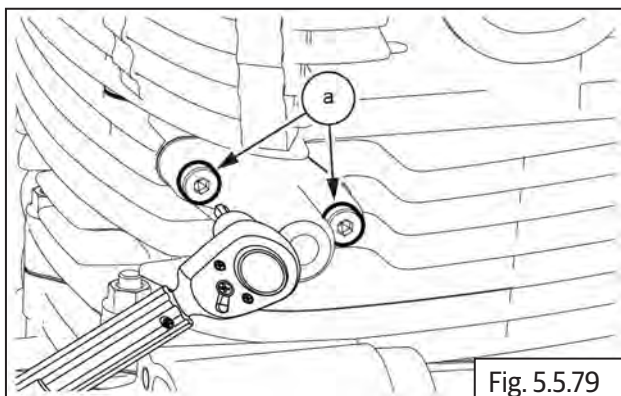

	5 mm Allen Socket with Ratchet
--	--------------------------------

- Remove auto chain tensioner **(a)** from cylinder barrel along with gasket **(b)**.

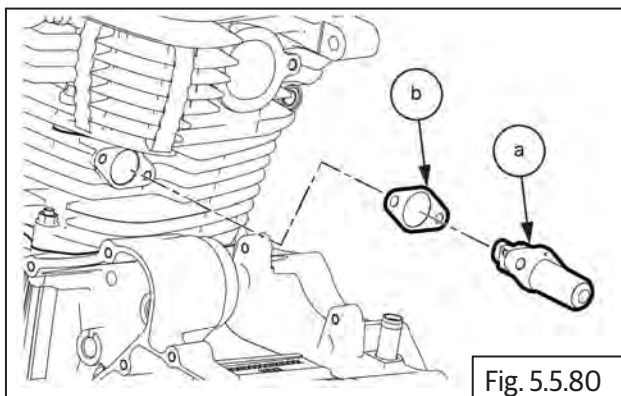

5.2.28 Rocker Carrier from Rocker Carriers

- Remove 2 Nos. hex flange carrier bolts **M6** **(a)**.

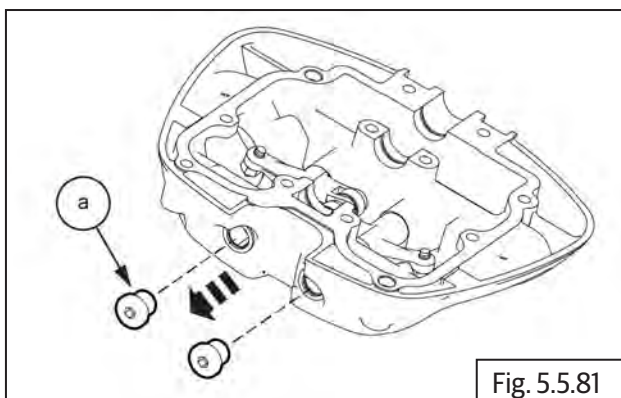

	6 mm Socket with Ratchet
--	--------------------------

- Remove the rocker carrier assembly **(a)**.

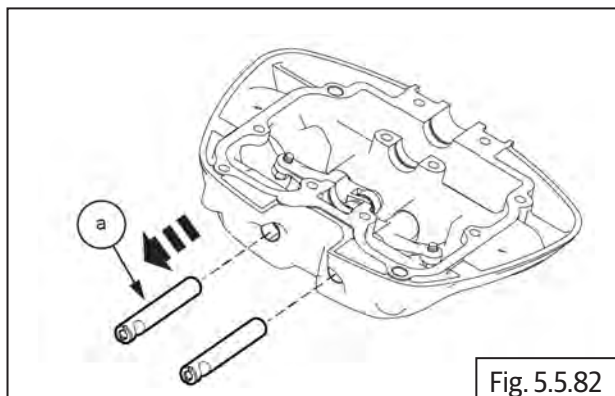

- Remove 2 Nos rocker arms **(a)** rocker carrier assembly.

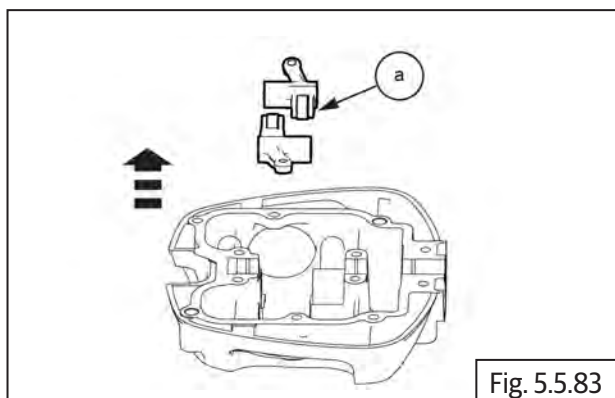

5.2.29 Center Cover LH

- Remove 2 Nos. hex bolt **(M6)** **(a)** and remove the center cover **(b)** along with the O-ring **(c)**.

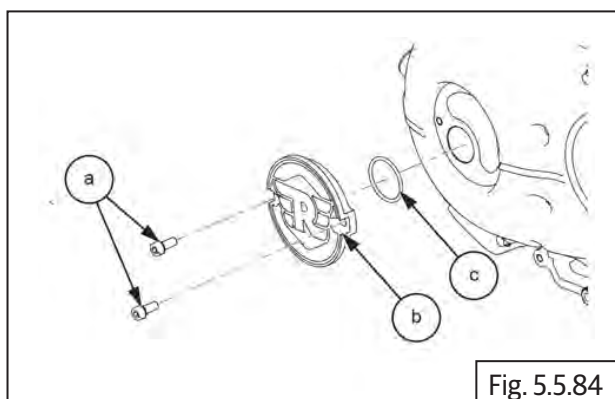

5.2.30 Cover LH

- Remove 14 Nos. Hex socket head bolts **(M6)** **(a)** in crisscross pattern to remove cover LH **(b)**.

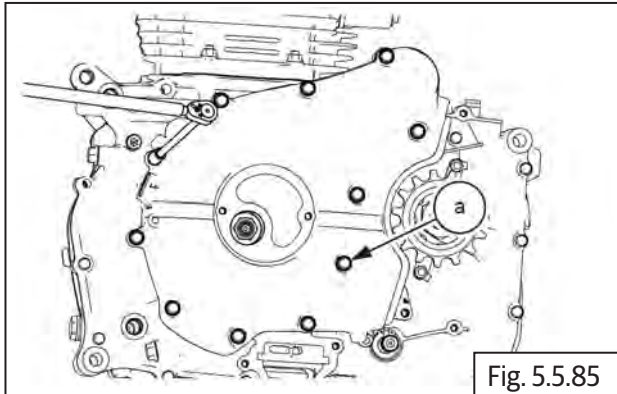

8 mm Hex socket with Ratchet

- Remove the gasket **(a)** with the blunt tool

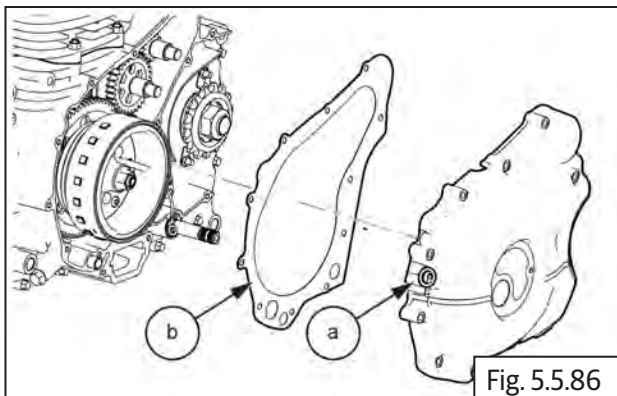

⚠ CAUTION

Do not use a sharp tool to scrap the gasket material from the joint faces.

If required scrap only with a soft and blunt tool.

- Remove dowel pin **(a)** from the crankcase.

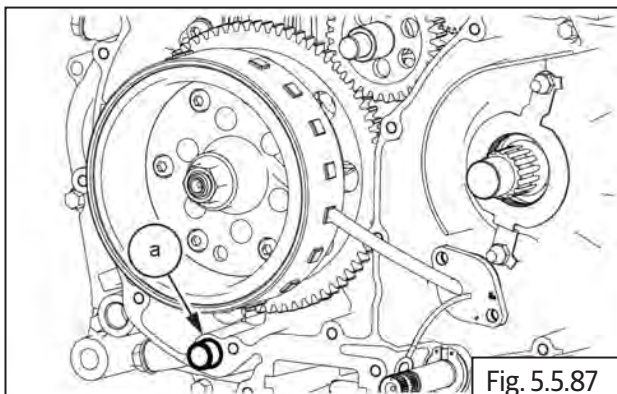

5.2.31 Idler Gear

- Remove the 2 Nos. Idle gear **(a)** and **(b)** with shaft-idler gear.

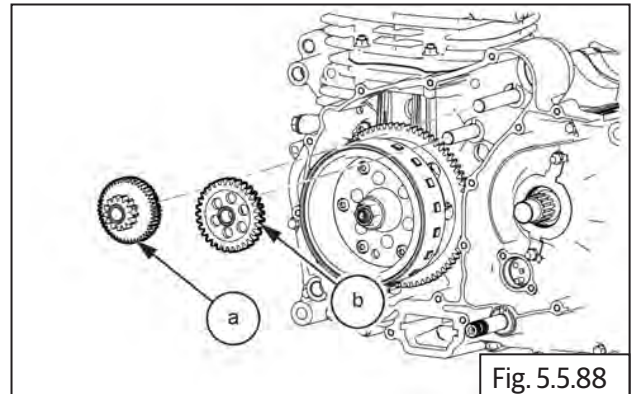

5.2.32 Cam Shaft, Sprocket & Chain

- Rotate magneto rotor only in anti-clockwise direction, till one of the Hex head bolt on cam chain sprocket appears at the top most position.

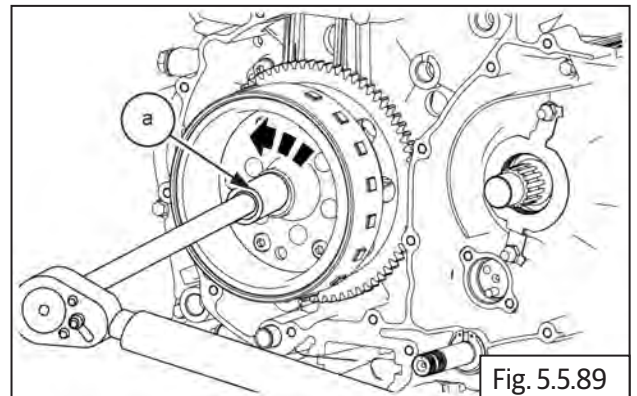

17 mm Socket with Ratchet

- Loosen and remove 1st Hex head bolt **(M6)** **(a)** from cam sprocket.

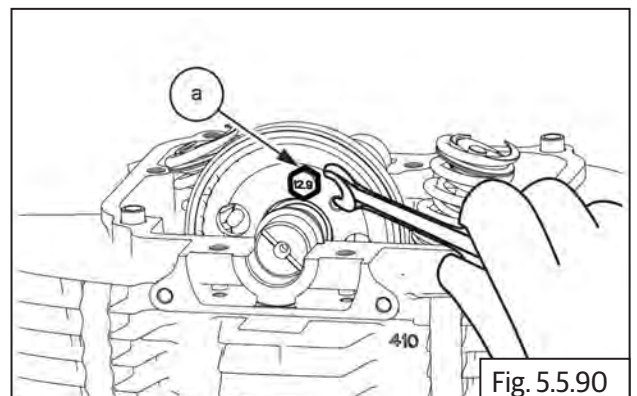

8 mm Socket with Ratchet

- Rotate magneto rotor only in anti-clockwise direction, till the other Hex head bolt on cam chain sprocket appears at the top most position.

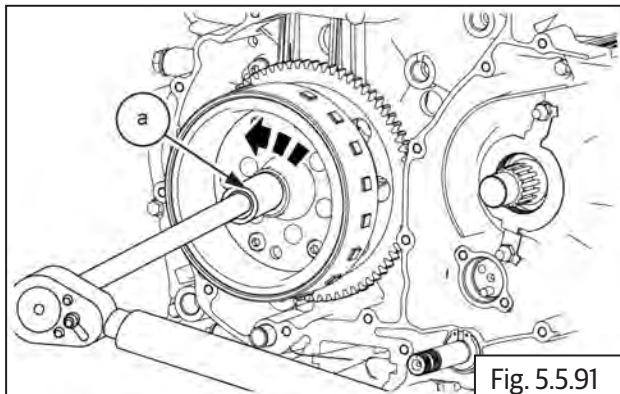

Fig. 5.5.91



17 mm Socket with Ratchet

- Loosen and remove 2nd Hex head bolt **(M6) (a)** from cam sprocket.

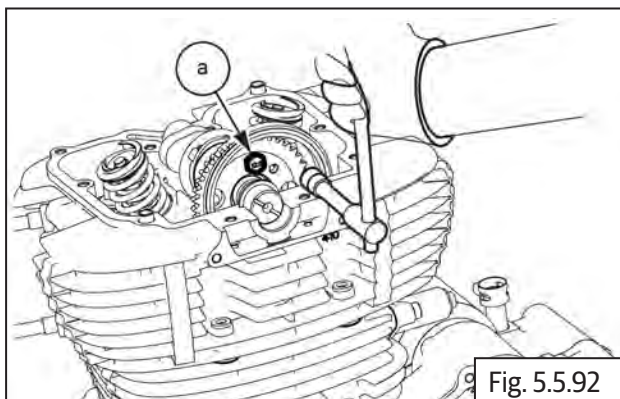

Fig. 5.5.92



8 mm Socket with Ratchet

- Remove cam chain **(b)** from cam sprocket **(a)** to remove cam sprocket.

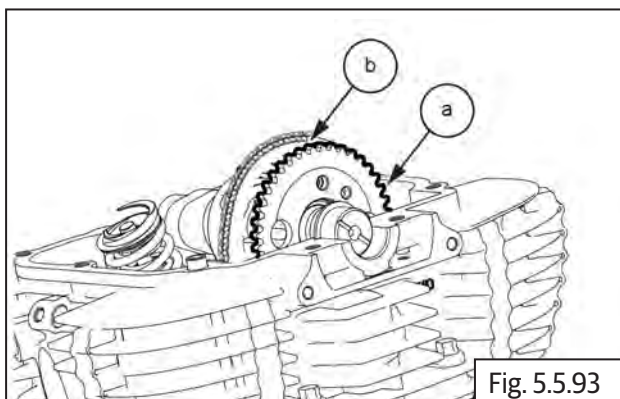

Fig. 5.5.93

⚠ CAUTION

Support timing chain suitable so that it does not fall into the crankcase.

- Remove "C" washer **(a)** from groove in cylinder head LH **(b)**.

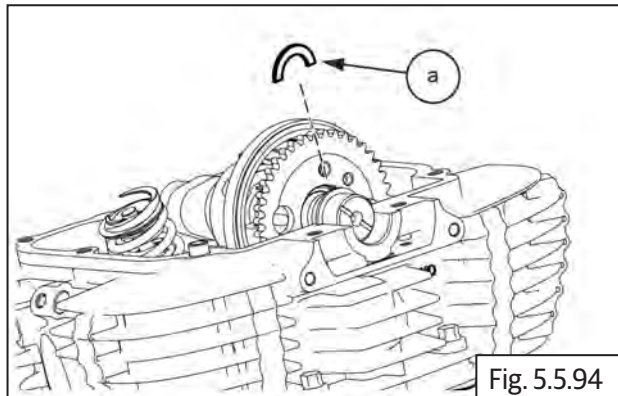

Fig. 5.5.94



Magnetic stick

- Remove camshaft **(a)** from cylinder head **(b)**.

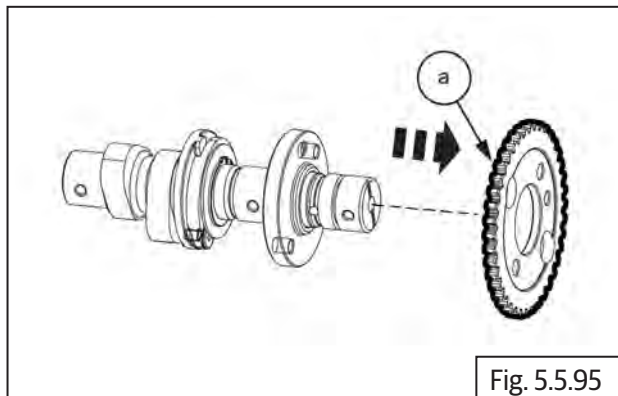

Fig. 5.5.95

- Support timing chain suitably at the top to prevent it from dropping into the crankcase.

5.2.33 Stator Assembly

- Remove 3 Nos. allen bolts **(M6) (a)** holding the stator assembly.

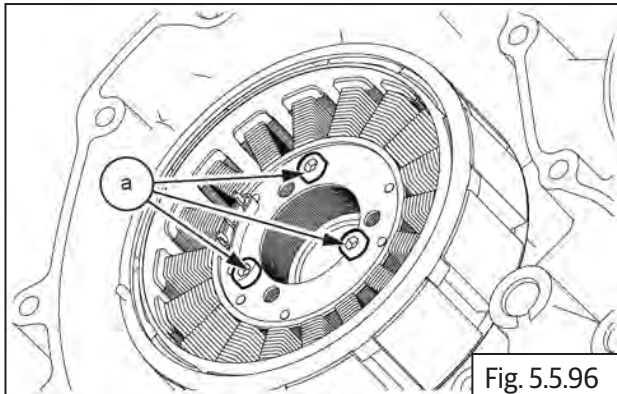

Fig. 5.5.96



5 mm Allen socket with Ratchet

Crank Position Sensor/Pickup Coil

- Remove 2 Nos. allen bolts **(a)** to release sensor.

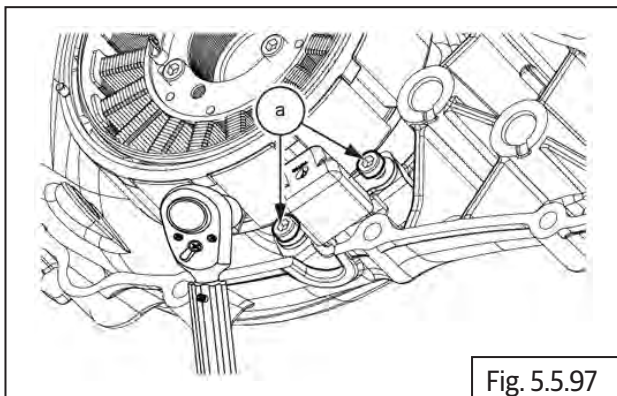

Fig. 5.5.97



4 mm Allen socket with Ratchet

- Remove the sensor **(a)** and guide plate.

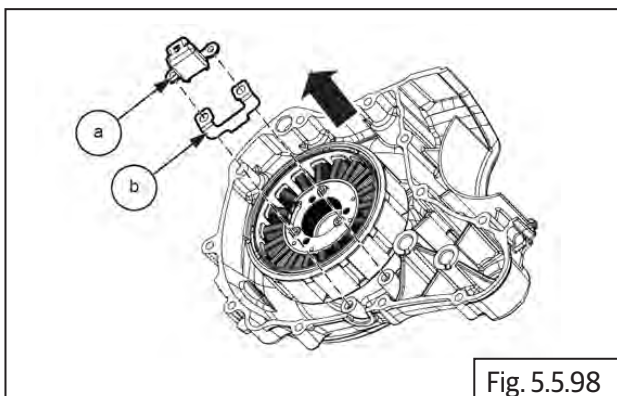

Fig. 5.5.98



4 mm Allen socket with Ratchet

- Gently remove stator assembly **(a)** from magneto cover.

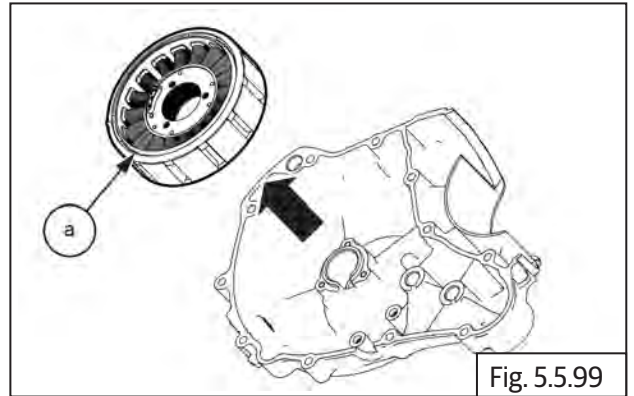

Fig. 5.5.99

5.2.34 Magneto Rotor Bolt

- In order to loosen magneto rotor bolt, Remove clutch cover Refer [\(Section 5.1.16\)](#).
- Insert special tool **(a)** in crankcase RH to lock the crankshaft.

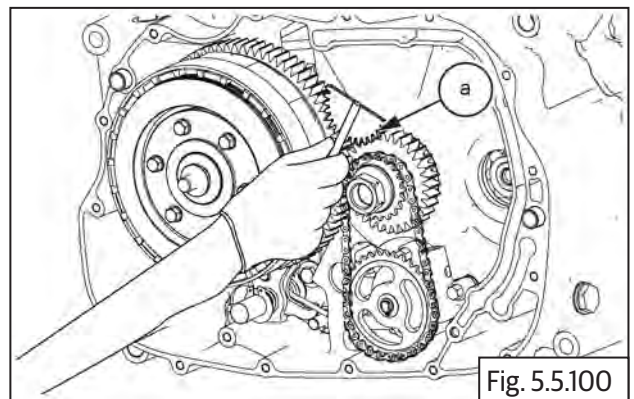
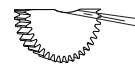

Fig. 5.5.100

SPL



Part No: ST-27533-2

Part Name: Crank Gears locking tool

- Loosen and remove Hex flange head bolt **(M12) (a)**.

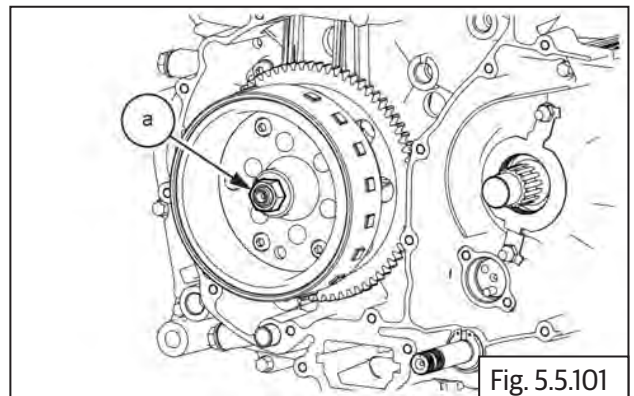
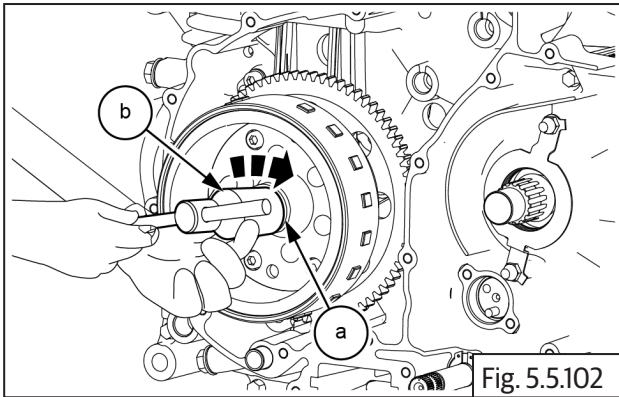



Fig. 5.5.101



17 mm Socket with Ratchet

- Assemble puller **(b)** on magneto rotor **(a)** and thread in fully.
- Tighten center bolt onto puller till magneto rotor gets released from crankshaft.



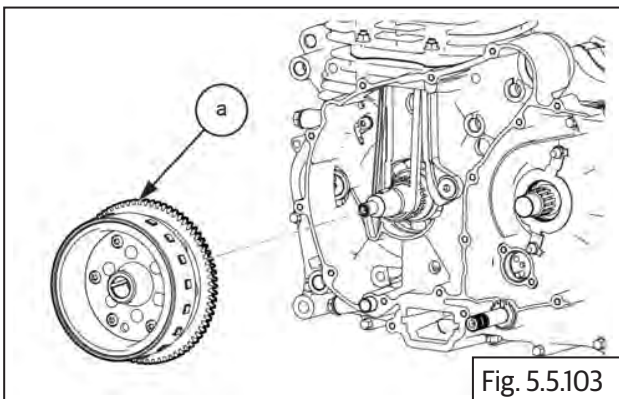

	Part No: ST30274/a
	Part Name: Magneto Puller Assembly

- Gently pull out magneto rotor assembly **(a)** with starter clutch.

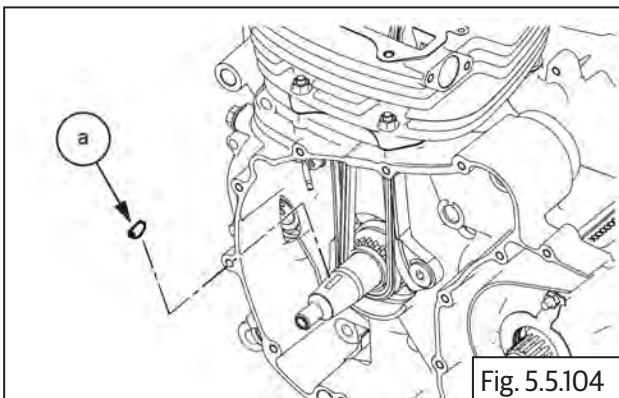

- Remove woodruff key **(a)** from crankshaft.



	Connector
---	-----------

5.2.35 Starter Clutch from Magneto Rotor

- Loosen 6 Nos. Hex socket head screws **(M6) (a)** from inside magneto rotor. **Do not LOOSEN AND REMOVE FULLY.**

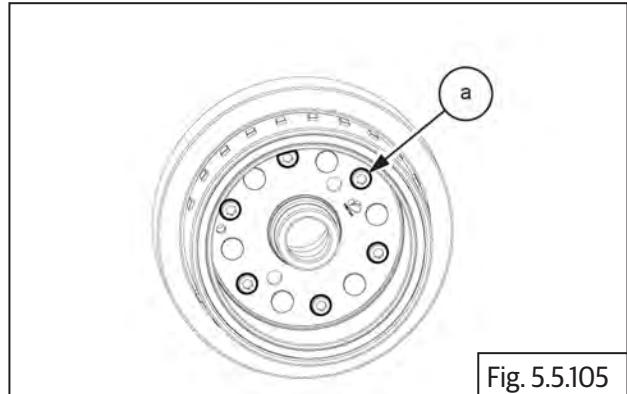

	5 mm Allen socket with Ratchet
---	--------------------------------

- Remove magneto rotor assembly **(a)** from crank shaft, hold the rotor firmly, rotate gear starter clutch **(b)** anti-clockwise and pull out simultaneously to separate rotor from the gear.

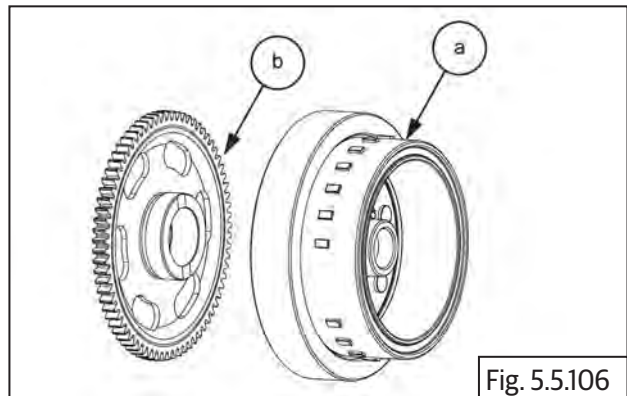

- Remove starter clutch **(a)** from inside magneto rotor **(b)**

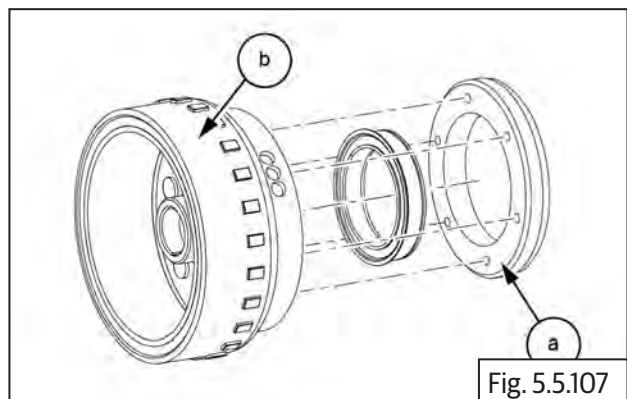

5.2.36 Cylinder Head

⚠ CAUTION

M10 Cylinder bolts and washers are one time usage only. Always use new head bolts and washers during installation. Dispose old head bolts suitably.

- Loosen and remove 4 Nos. Hex head bolts (**M10**) (**a**) in crisscross pattern on cylinder head.

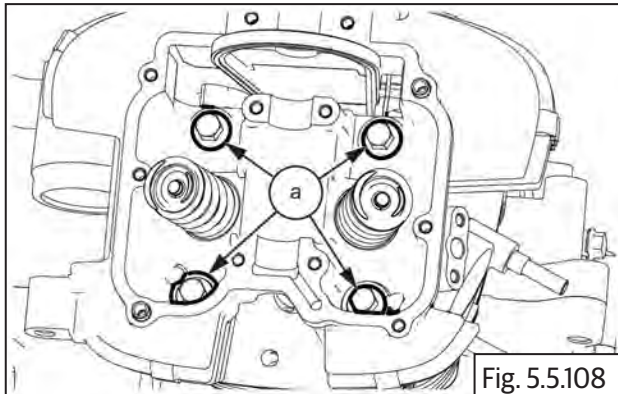

12 mm Socket with Ratchet

- Loosen and remove 2 Nos. Hex head bolts (**M6**) (**a**) on cylinder head.

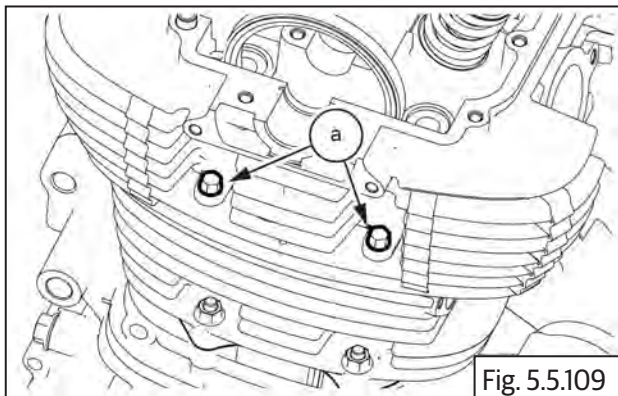

8 mm Socket with Ratchet

- Support cam chain suitably and gently remove cylinder head (**a**) from cylinder barrel (**b**).

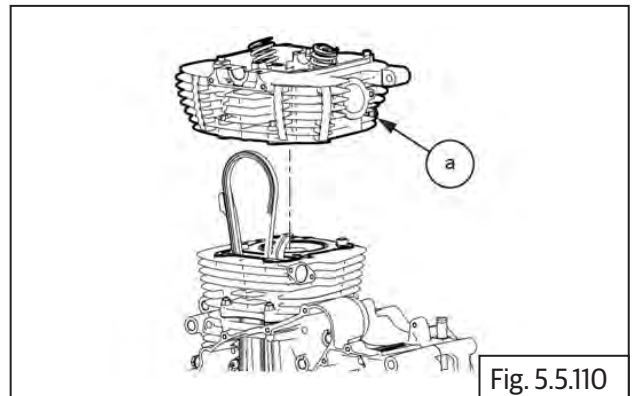

- Remove the cylinder head gasket (**a**) from cylinder barrel (**b**).

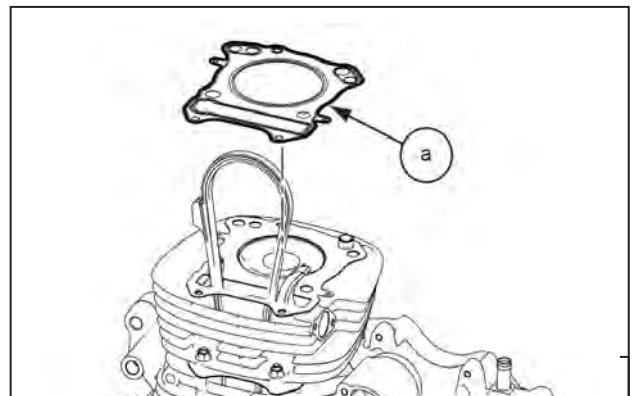

- Remove 2 nos dowel pins (**a**) on cylinder head.

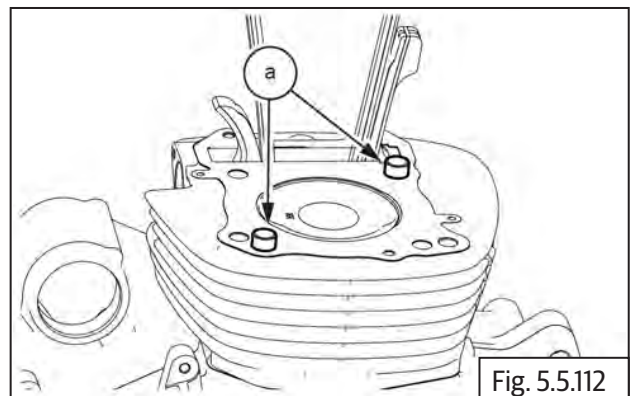

Nose Plier

5.2.37 Components from Cylinder Head

Valves and Springs

- Compress valve spring **(a)** with valve spring compressor **(b)**.

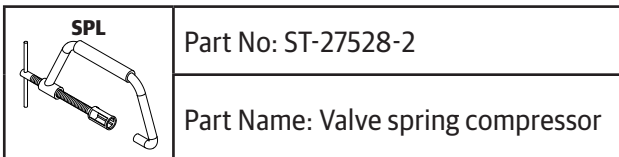
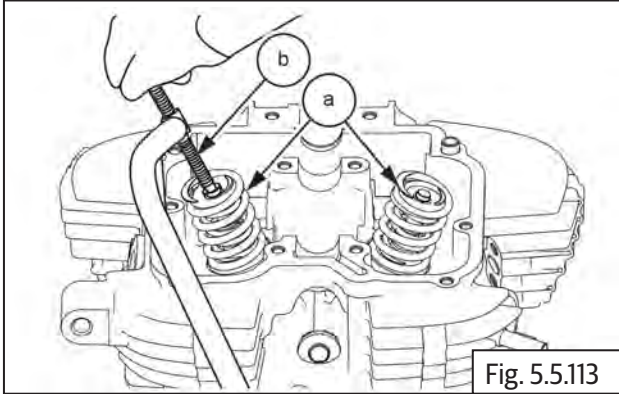

- Remove the cotters **(a)** on valve stem at the top.

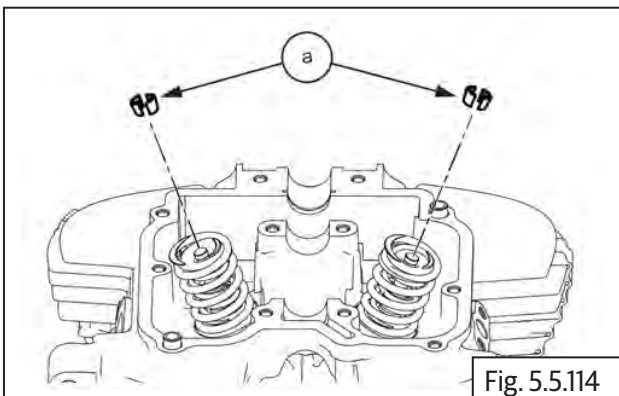

- Gently loosen the screw on valve spring compressor, till the valve spring tension is completely released and remove the special tool.

! CAUTION

Valve spring under high tension when compressed.

Release valve spring compressor tool slowly.

- Remove the retainer, valve spring **(a)** from the top of the valve spring **(b)**.

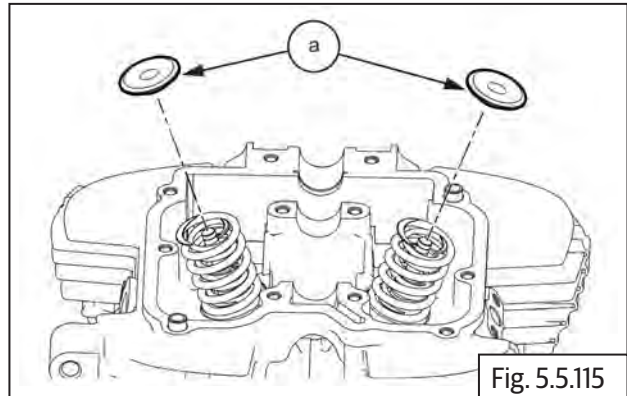

- Remove valve spring **(a)** from valve stem **(b)**.

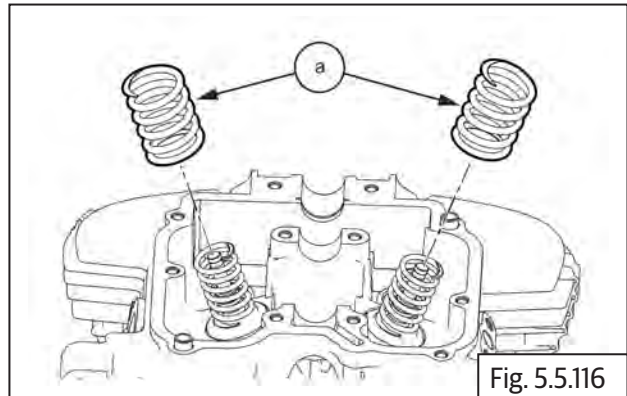

NOTE

- Mark the position of the spring before removing
- Remove valve **(a)** from cylinder head **(b)** by pulling it out from the cylinder head inside.

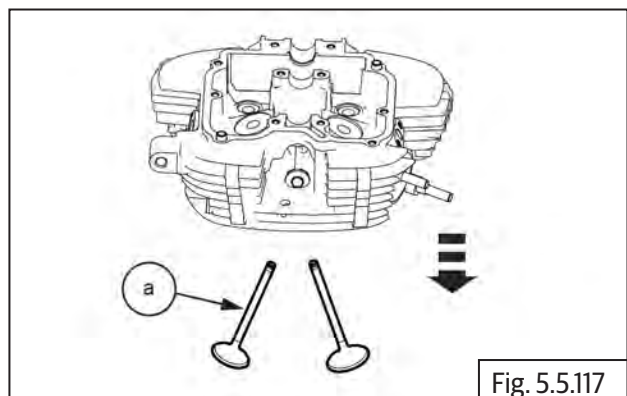

- Remove valve stem seal **(a)** from valve guide **(b)**.

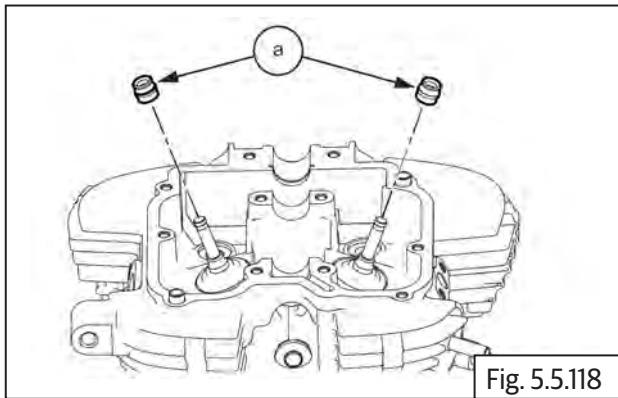

Guide pad - Cam chain

- Remove the guide pad bolt **(a)** from the guide pad.

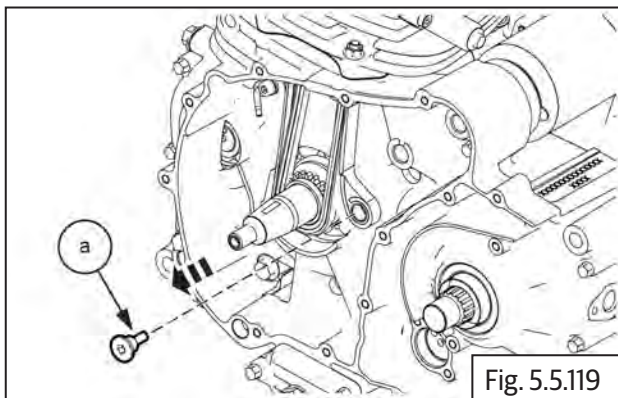

- Remove cam chain **(a)** from cylinder barrel.

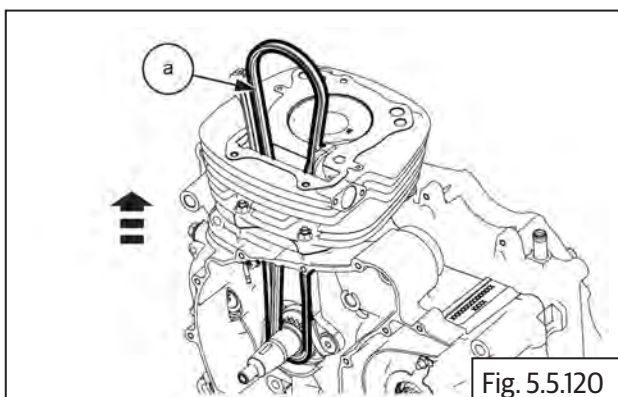

- Remove the guide pad **(a)**.

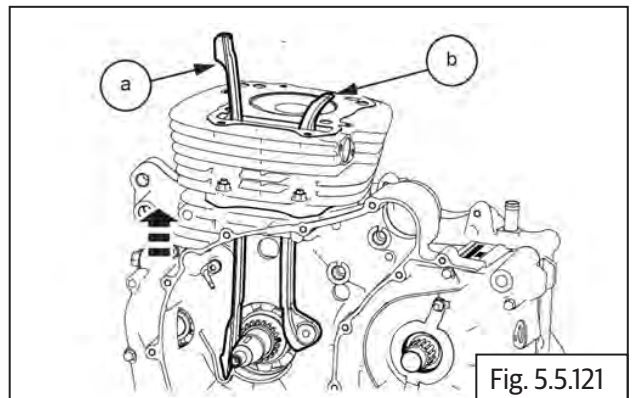

5.2.38 Cylinder Barrel

- Remove the 2 No. nut from the LH cylinder barrel

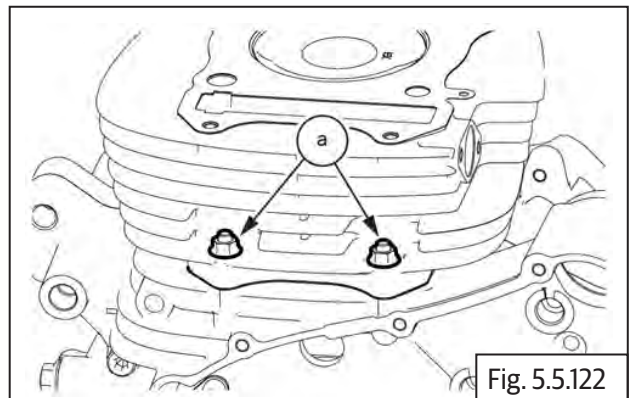

- Slightly tilt and gently remove the cylinder barrel **(a)** from crankcase **(b)**.

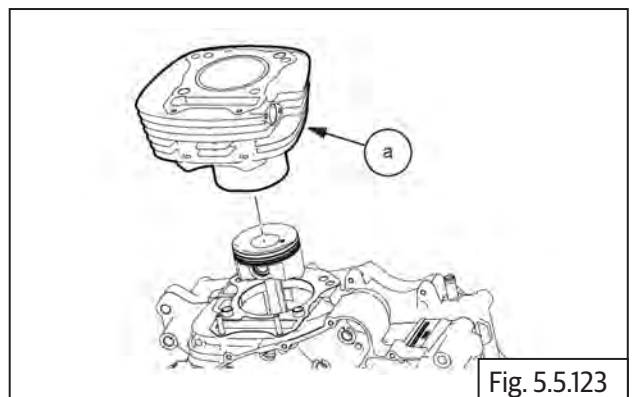

- Remove 2 nos dowel pin (a) from cylinder barrel

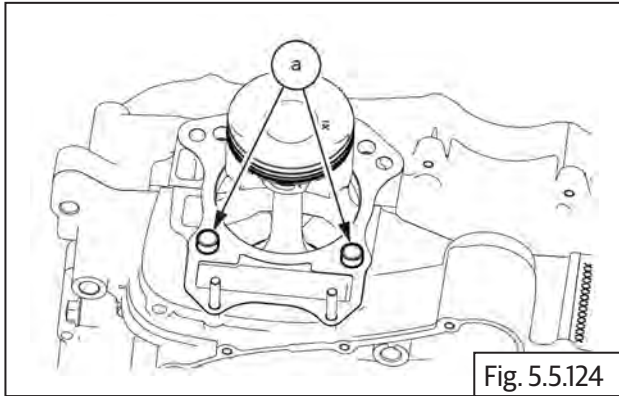

5.2.39 Piston

! CAUTION

Cover the crankcase opening below the piston with a cloth to avoid circlip falling into the crankcase.

- Remove the circlip (a) from piston.

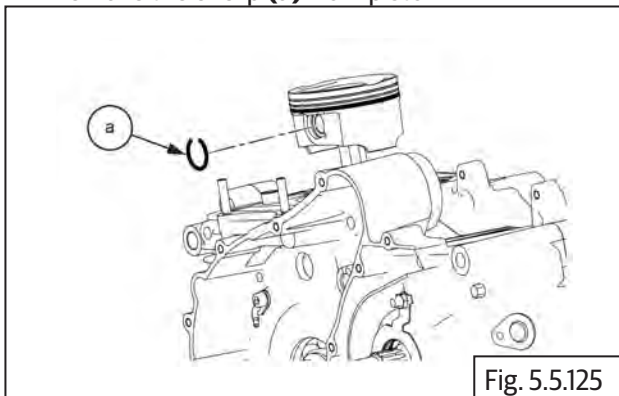

- Gently push out the gudgeon pin (a) to release the piston (b).

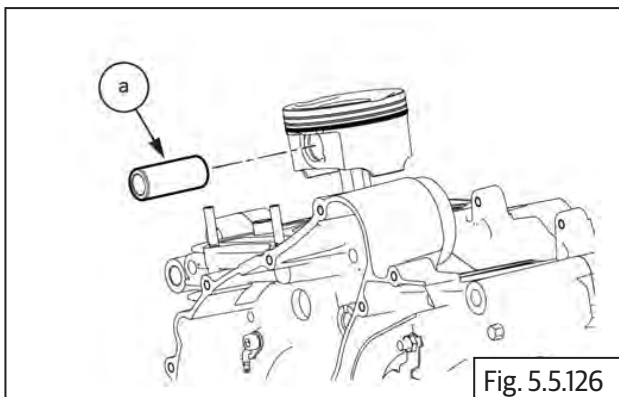

5.2.40 Crankcase Fasteners

Description	Quantity
M8	4
M6 x 1.25 x 35	16

- Support crankcase assembly on suitable wedges such that the fasteners on the crankcase can be removed.
- Slackening sequence.

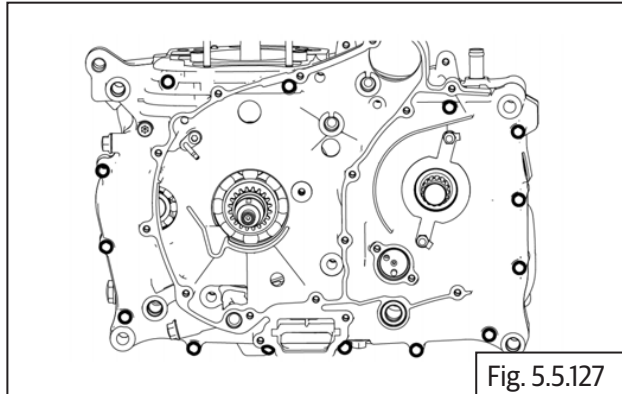

5.2.41 Splitting Crankcase

- Ensure the crankcase is supported firmly on suitable wedges.
- Gently separate the LH crankcase from the RH crankcase by slightly tapping on the tabs (a) provided in LH crankcase, to release from the dowels and sealing gasket material.

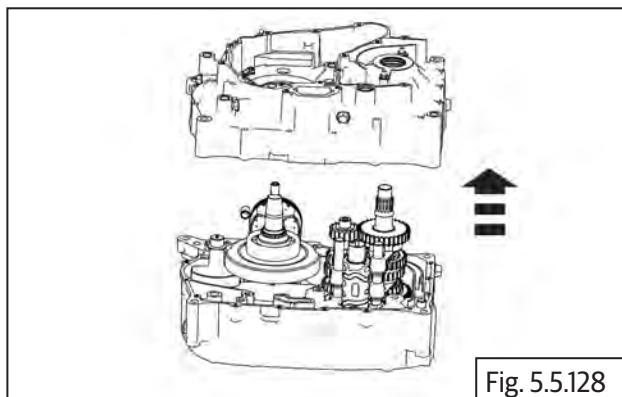

- Remove RH crankcase along with the gear selector drum, from the upper crankcase.
- Remove 2 Nos dowel pins **(a)** from crankcase.

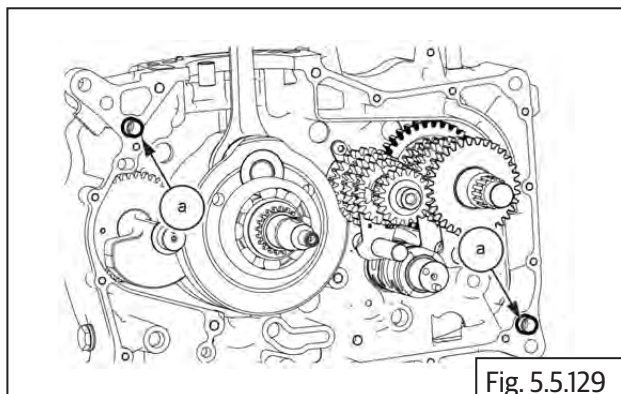

⚠ CAUTION

Ensure all the mounting fasteners on the crankcase have been removed.

Ensure the gear shift forks are not jammed in the grooves in the gears.

Ensure the dowels are removed from the LH and RH crankcases.

5.2.42 Balancer Shaft

- Match the punch mark **(a)** in balancer shaft and crankshaft.

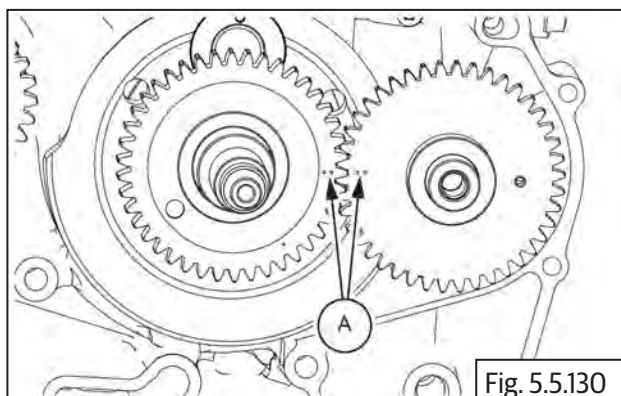

- Remove balancer shaft **(a)**.

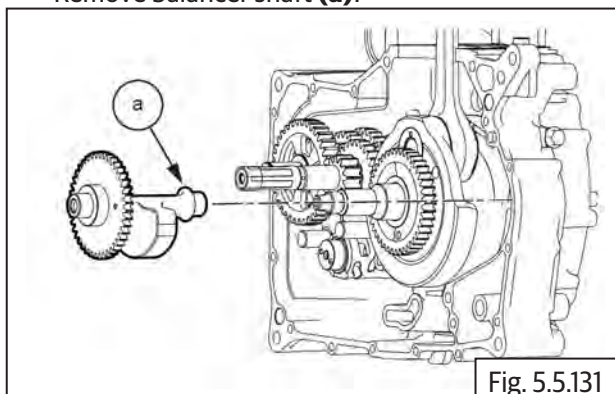

5.2.43 Crankshaft Assembly

⚠ CAUTION

Crankcase bolts are one time use only.

Bolts are non reusable

- Gently lift and remove crankshaft assembly **(a)** from crankcase.
- Use a mallet if required.

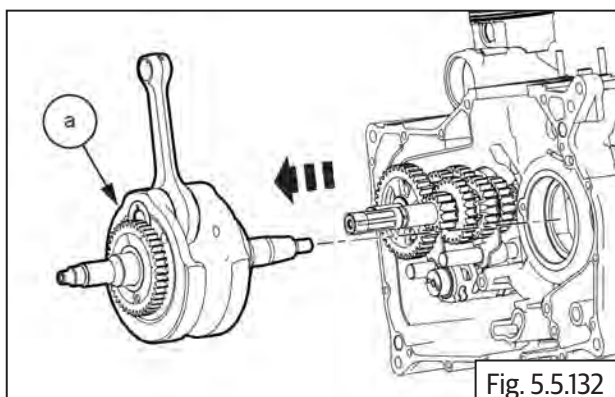

5.2.44 Gear Selector

- Gently pull to remove transmission selector drum **(a)** with selector forks **(b)** and spindles **(c)**.

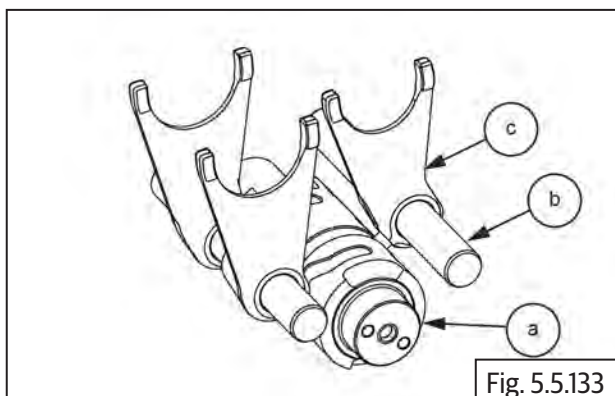

- Remove spindle **(a)** from forks **(c)** from selector drum **(b)**.

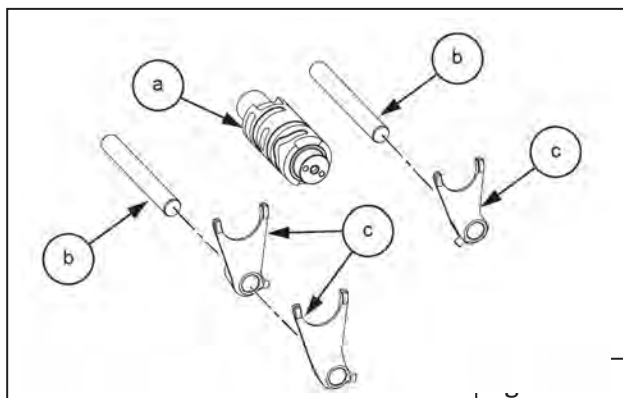

5.2.45 Countershaft

- Place countershaft separately.

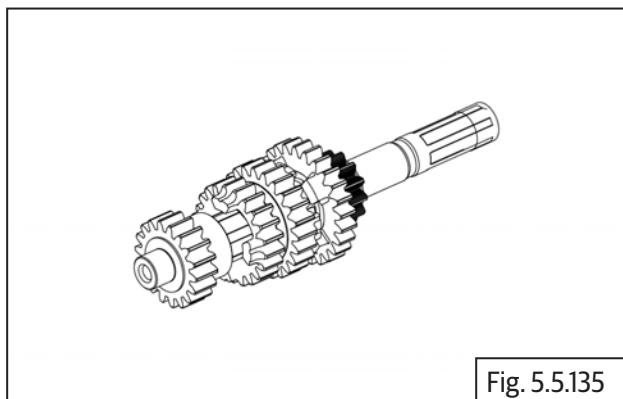
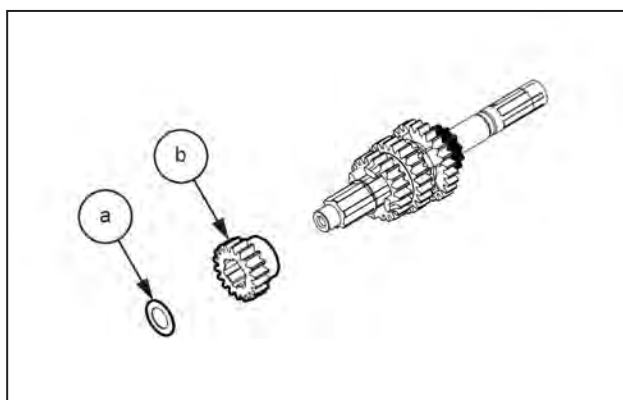

Fig. 5.5.135

- Remove thrust washer **(a)** and second drive gear **(b)** from the countershaft smaller end.



- Remove circlip **(a)** from the countershaft.

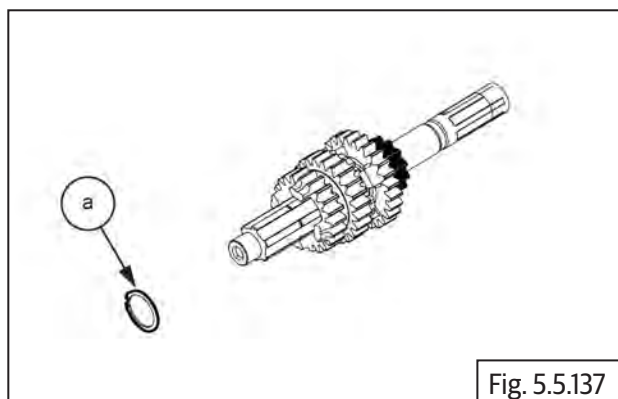

Fig. 5.5.137



Circlip Expander

- Remove the third and fourth drive gear **(a)** from the countershaft.

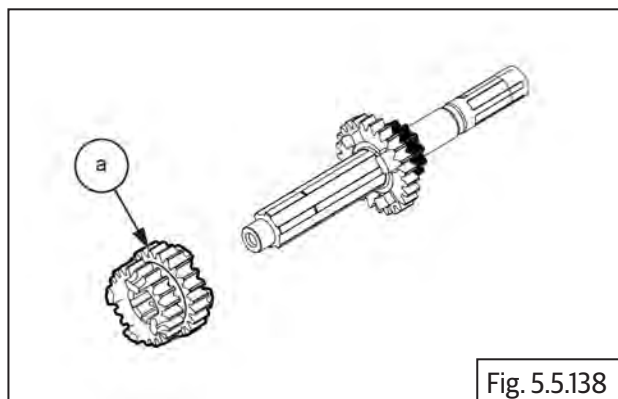

Fig. 5.5.138

- Remove the final gear **(a)** from the countershaft.

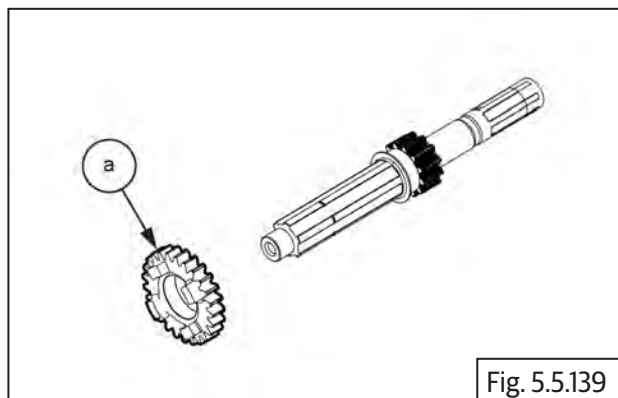

Fig. 5.5.139

- Remove the circlip **(a)** along with washer **(b)** and bush **(c)** from countershaft.

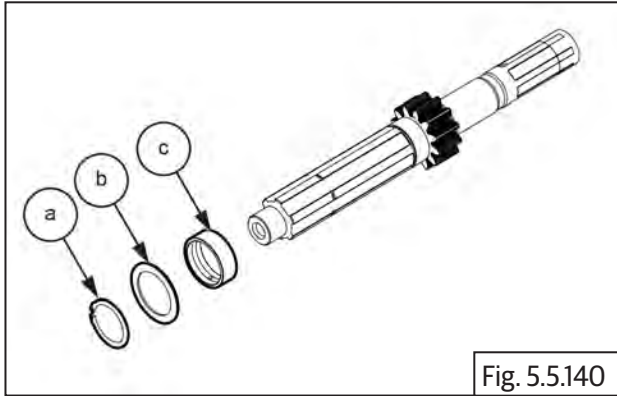

Fig. 5.5.140



Circlip Expander

- Remove thrust washer **(a)** and second drive gear from the countershaft

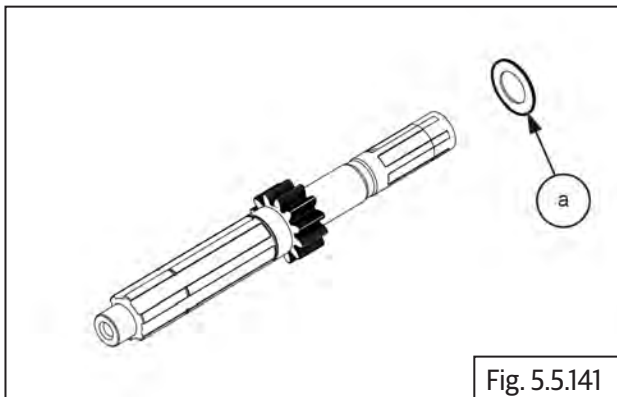

Fig. 5.5.141

5.2.46 Driveshaft

- Place the drive shaft separately.

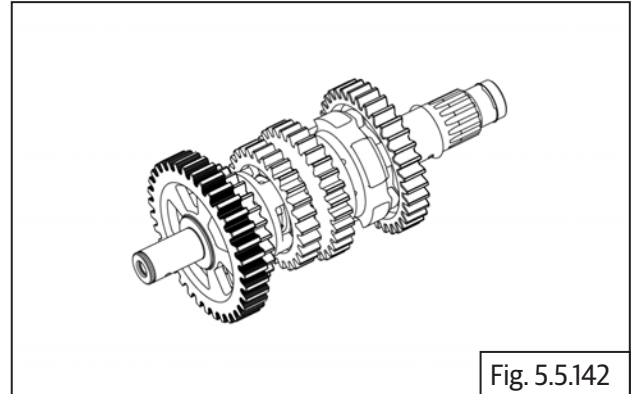

Fig. 5.5.142

- Remove thrust washer **(a)** and first driven gear **(b)** from driveshaft.

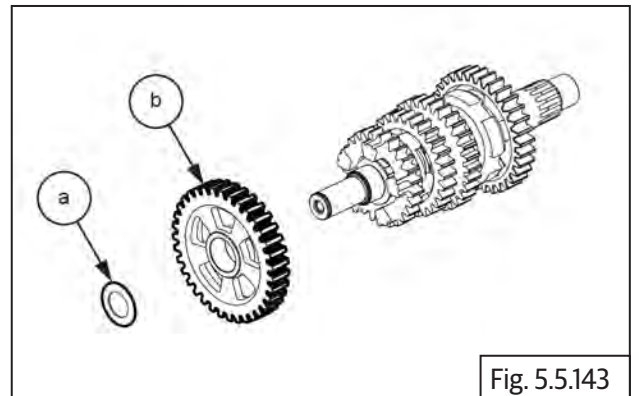

Fig. 5.5.143

- Remove circlip **(a)** from groove in the driveshaft.

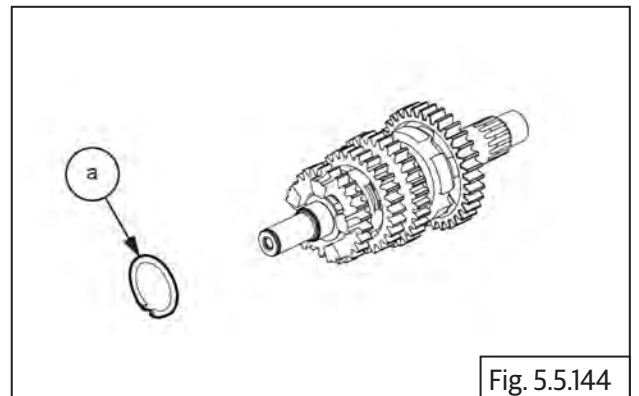
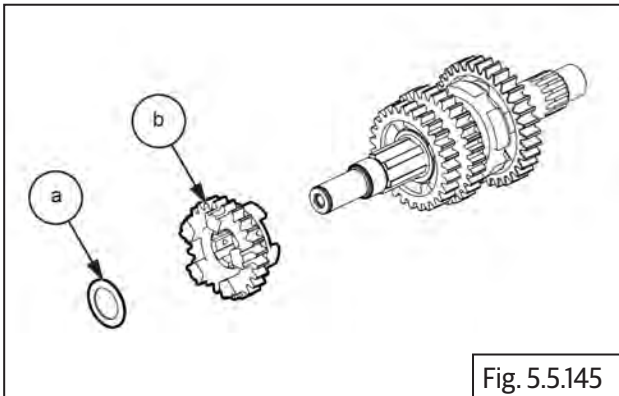

Fig. 5.5.144



Circlip Expander

- Remove thrust washer **(a)** and fifth driven gear **(b)**



- Remove splined washer **(a)** from driveshaft.

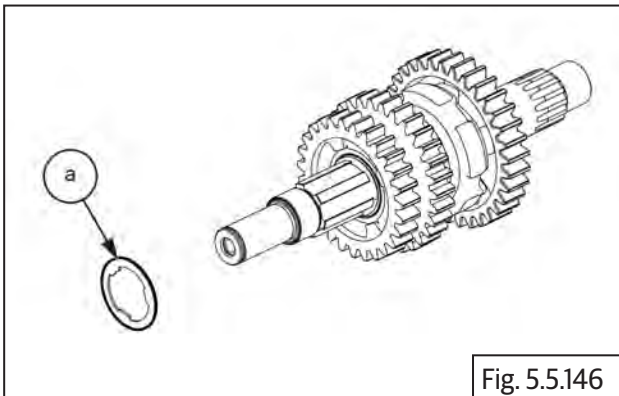

- Remove fourth driven gear **(a)** from driveshaft.

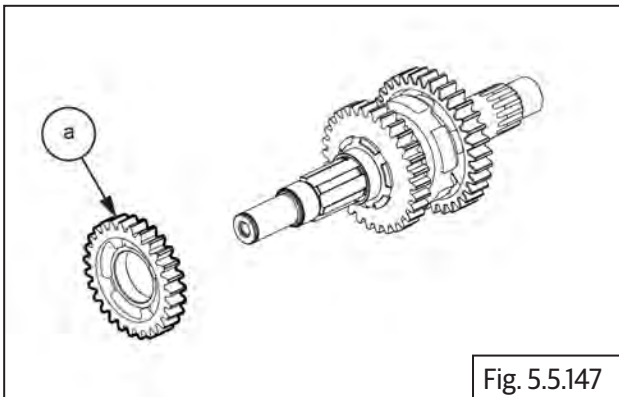

- Remove collar **(a)** along with splined washers **(b)**, **(c)** from the driveshaft.

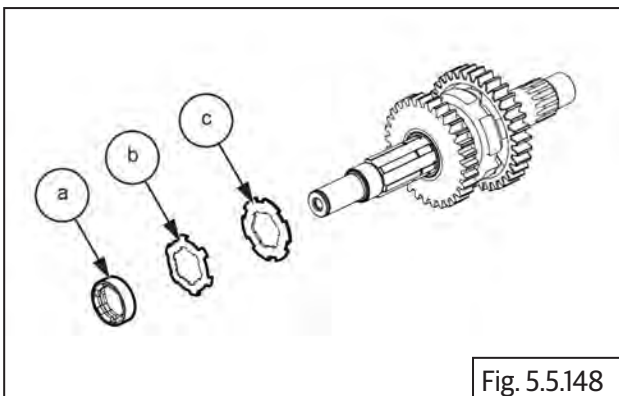

- Remove the third driven gear (a) from the drive shaft.

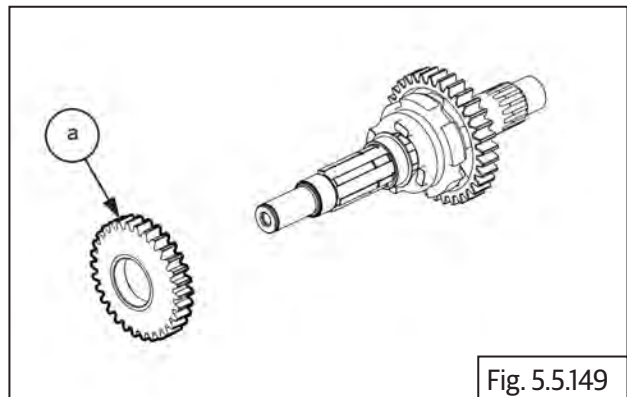

- Remove collar **(a)** along with thrust washer **(b)** and circlip **(c)** from the drive shaft.

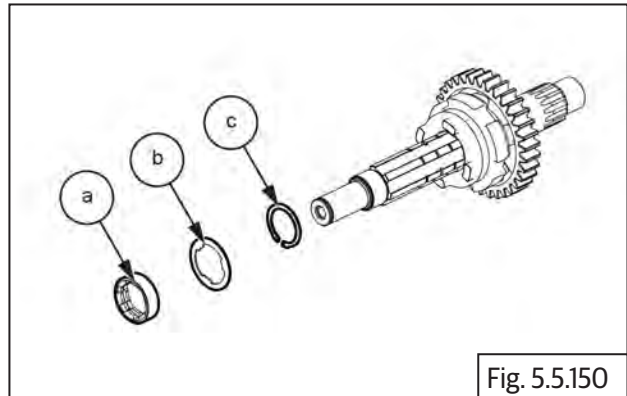

Circlip Expander

- Remove the sliding bush **(a)** from the driveshaft.

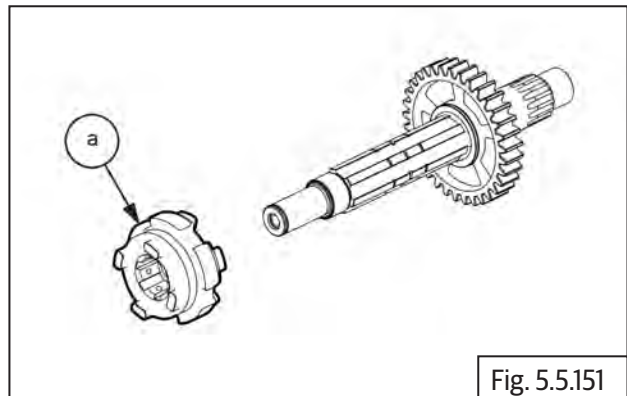

- Remove circlip **(a)** and bush **(b)** from driveshaft.

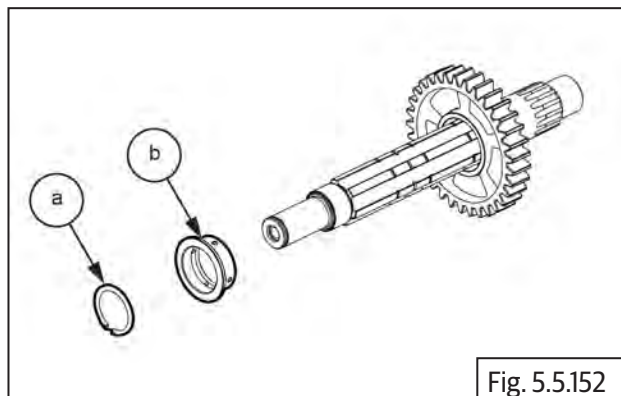

- Remove second driven gear **(a)** from driveshaft.

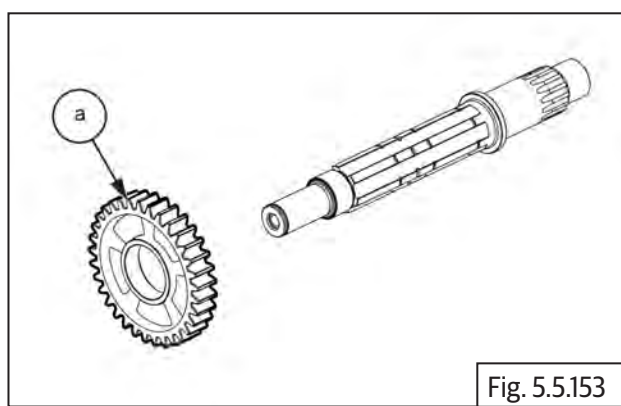

ENGINE ASSEMBLY

Engine Assembly

CONTENTS	PAGE
5.3 Engine Assembly	97
5.3.1. Components Sub Assembly in Crankcase.....	97
5.3.2. Countershaft Components	97
5.3.3. Driveshaft Components.....	98
5.3.4. Transmission Selector Drum	100
5.3.5. Crankshaft Assembly	100
5.3.6. Balancer Shaft.....	100
5.3.7. Dowel pins.....	101
5.3.8. Crankcase Closing.....	101
5.3.9. Crankcase Bolts Tightening Procedure.....	101
5.3.10. Piston and Piston Rings.....	102
5.3.11. Cylinder Barrel.....	103
5.3.12. Valves and Springs.....	104
5.3.13. Cylinder Head	105
5.3.14. Timing chain on Crankshaft.....	106
5.3.15. Woodruff Key on Crankshaft	106
5.3.16. Magneto Rotor on Crankcase	107
5.3.17. Camshaft Assembly.....	108
5.3.18. Rocker Carrier in Cylinder Head.....	109
5.3.19. Tappet Clearance Adjustment	110
5.3.20. Cylinder Head Cover	111
5.3.21. Spark Plug.....	112
5.3.22. Star Index.....	113
5.3.23. Star Index Stopper	113
5.3.24. Gear Shifter Shaft	113

Engine Assembly

CONTENTS

PAGE

5.3.25. Clutch Assembly (LH thread).....	114
5.3.26. Crank gear (LH Thread)	116
5.3.27. Balancer Shaft Bolt.....	117
5.3.28. Oil Pump	117
5.3.29. Oil Jet.....	118
5.3.30. Oil Level Window.....	118
5.3.31. Oil Bypass seal	118
5.3.32. Clutch Actuating Lever Assembly.....	119
5.3.33. Cover crankshaft center.....	119
5.3.34. Cover RH.....	119
5.3.35. Starter Idler Gear	121
5.3.36. Cover LH	121
5.3.37. Gear Position Sensor	122
5.3.38. Starter motor	122
5.3.39. Oil Strainer	123
5.3.40. Breather Hose	123
5.3.41. FD sprocket	124
5.3.42. Throttle Body.....	124
5.3.43. Engine Oil Temperature/EOT sensor	125
5.3.44. Oil Cooler	125

5.3 Engine Assembly

5.3.1. Components Sub Assembly in Crankcase

5.3.2. Countershaft Components

NOTE

- Do not reuse thrust washers, circlips, collar bush.
- Ensure all components are cleaned and lubricated with recommended lubricants before assembly
- Apply engine oil on gears before installation.

- Install thrust washer **(a)** on countershaft.

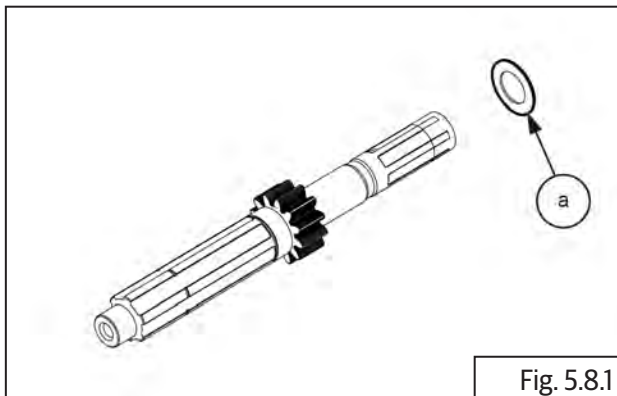

- Install bush **(c)** with thrust washer **(b)** and circlip **(a)** on countershaft.

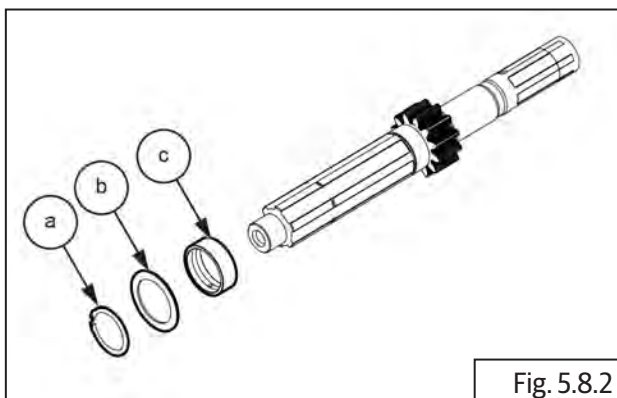

- Install the final gear **(a)** on countershaft with dog on the gear tooth facing outside.

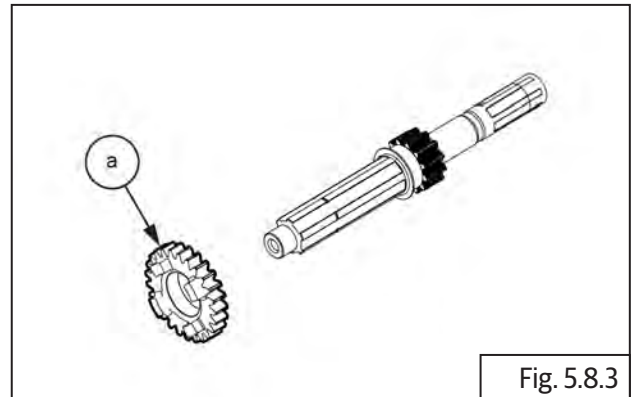

- Install the third and fourth drive gear **(a)** on countershaft.

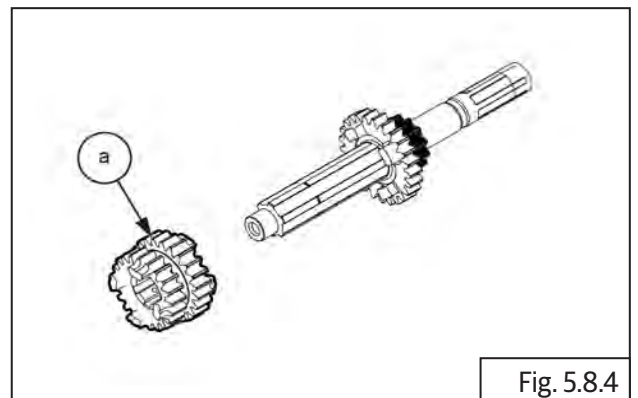

- Install circlip **(a)** and gently rotate circlip without expanding to ensure it is properly seated.

NOTE

- While installing the circlip, ensure the circlip is opened only upto the outer diameter of the shaft.

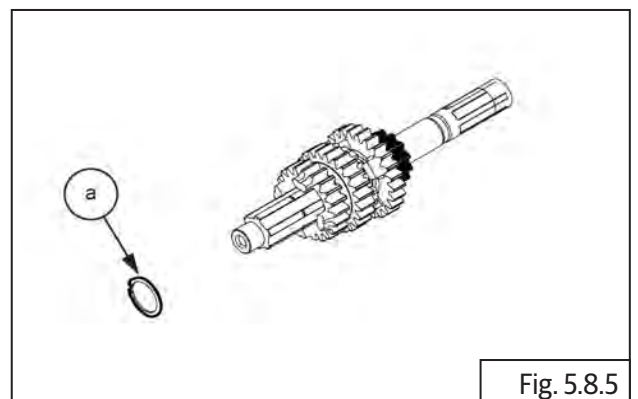

Circlip Expander

- Install the second drive gear (a) and washer (b) on the countershaft.

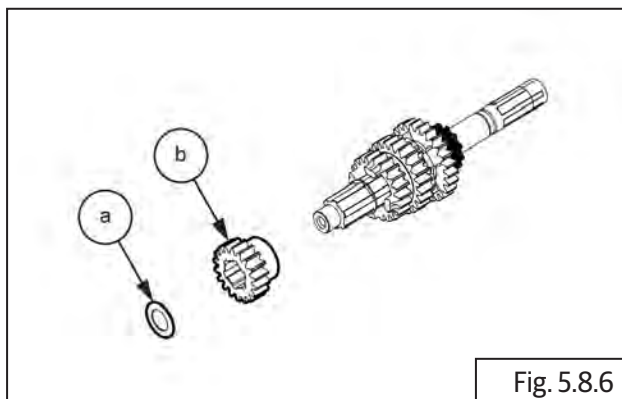

Fig. 5.8.6

5.3.3. Driveshaft Components

- Install second driven gear (a) on the driveshaft.

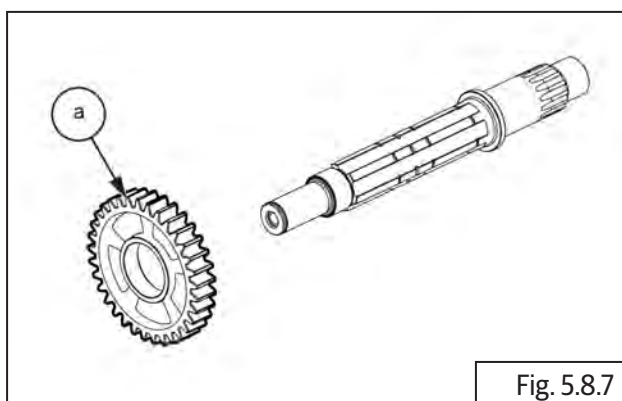

Fig. 5.8.7

- Install the bush (b) along with circlip (a) and gently rotate circlip without expanding to ensure it is properly seated and ensure free rotation of gear in bush.

NOTE

- While installing the circlip, ensure the circlip is opened only upto the outer diameter of the shaft.

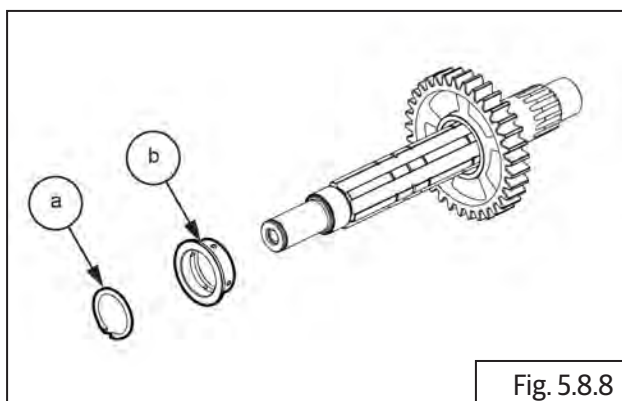
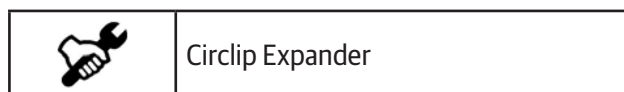

Fig. 5.8.8



Circlip Expander

- Install slide bush (a) on the drive shaft.

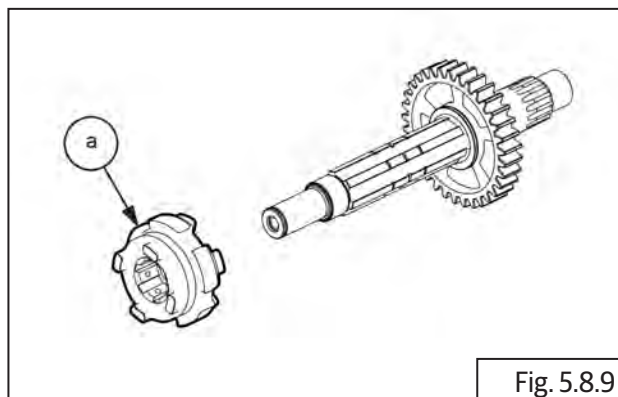

Fig. 5.8.9

- Install collar (a) along with thrust washer (b) and circlip (c).

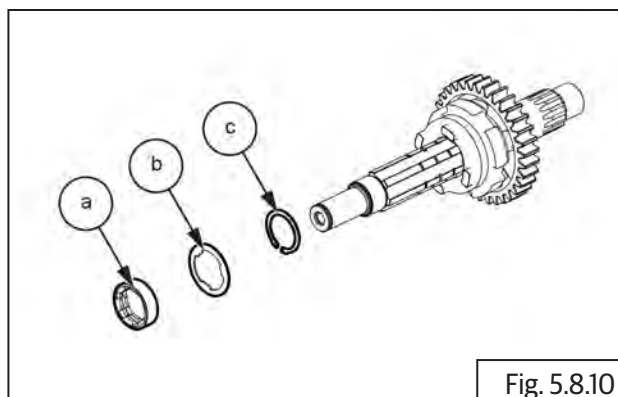

Fig. 5.8.10

- Install third driven gear (a) on the driveshaft.

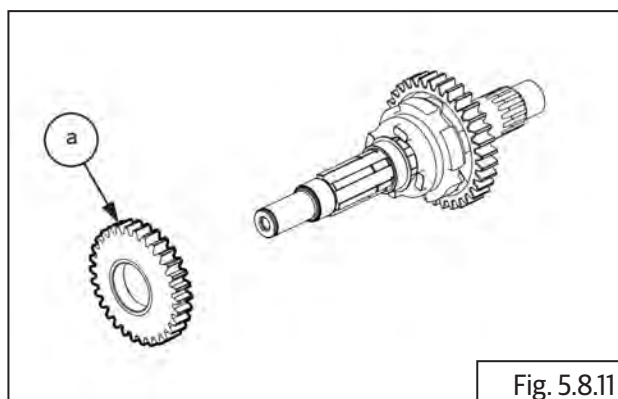
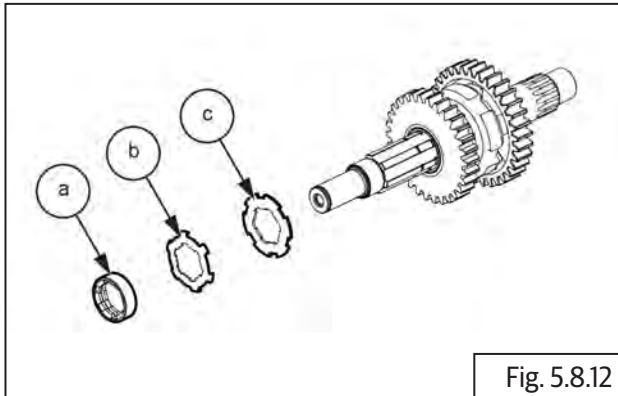
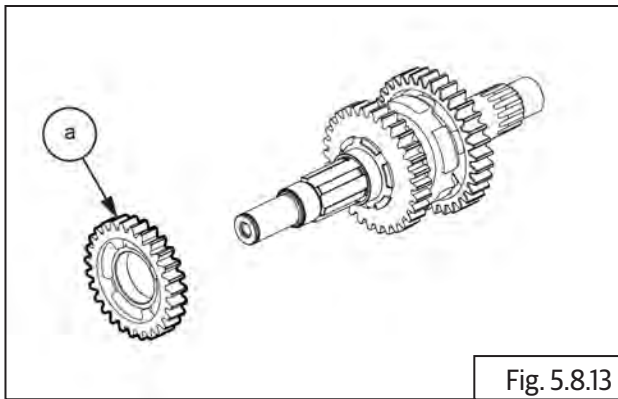

Fig. 5.8.11

- Install collar **(a)** along with splined washers **(b), (c)** on the drive shaft



- Install fourth driven gear **(a)** on the driveshaft.



NOTE

- While installing the circlip, ensure the circlip is opened only upto the outer diameter of the shaft.
- Install thrust washer **(a)** on the drive shaft.

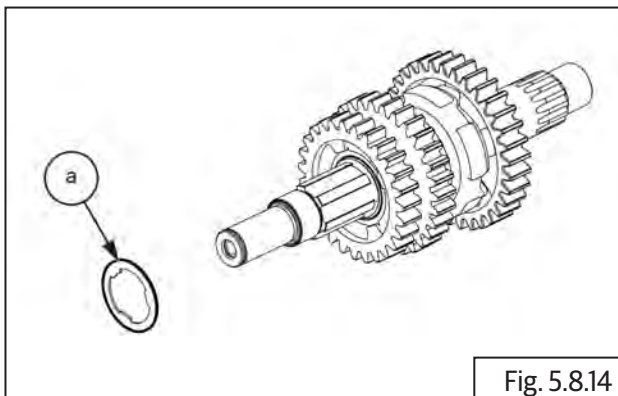

- Install the thrust washer **(a)** along with fifth gear **(b)** with dog on gear tooth facing the third gear on the driveshaft.

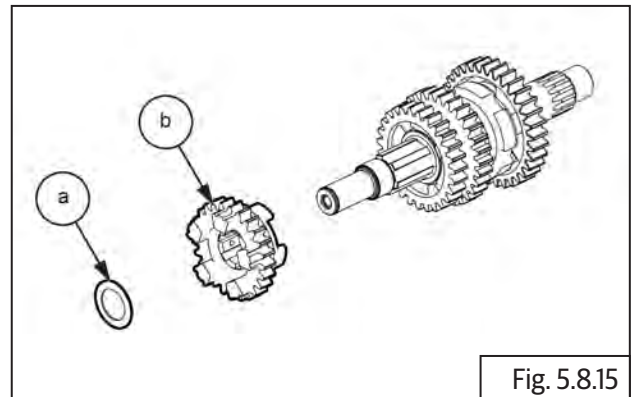

- Install circlip **(a)** and gently rotate circlip without expanding to ensure it is properly seated and ensure free rotation of gear in bush

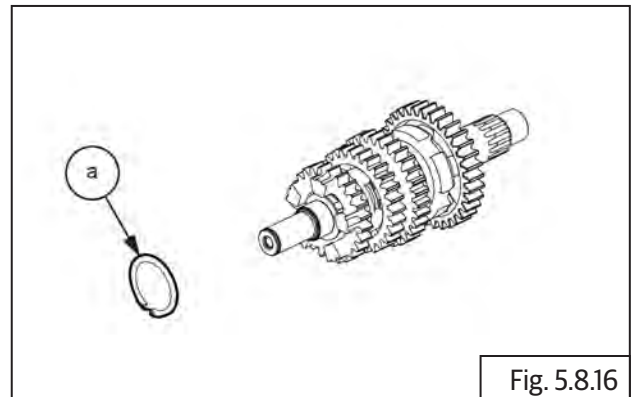

Circlip Expander

- Install first gear **(b)** and thrust washer **(a)** on the driveshaft.

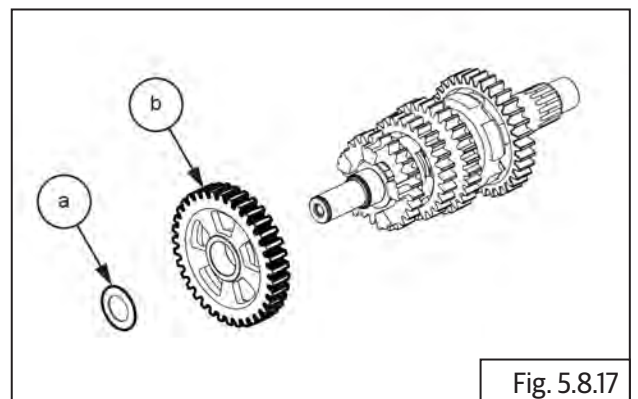

5.3.4. Transmission Selector Drum

NOTE

- Lubricate selector drum and forks with engine oil before installation.

- Install driveshaft and countershaft in LH crankcase.
- Install selector fork as shown below. Ensure fork identification marks to be facing towards RH crankcase.

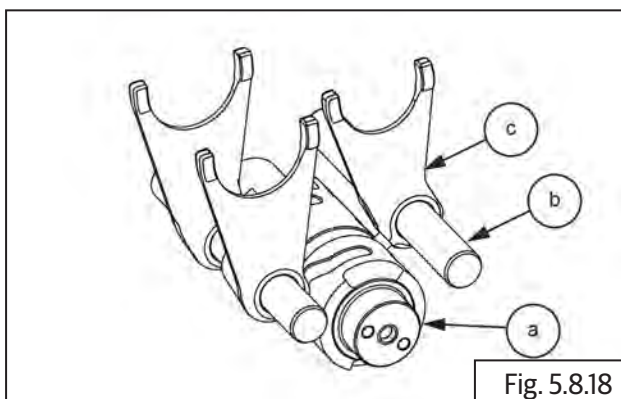

- Assemble forks in fourth and fifth gear of drive shaft.
- Likewise assemble fork in third gear in countershaft.

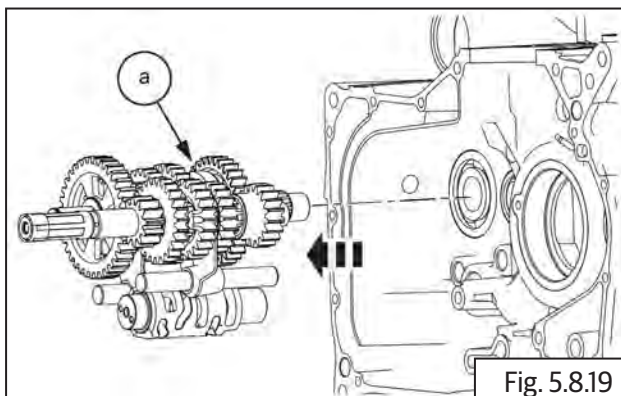

5.3.5. Crankshaft Assembly

NOTE

- Lubricate crankshaft big end bearing with engine oil before installation

- Gently install crankshaft assembly (a) on LH crankcase.

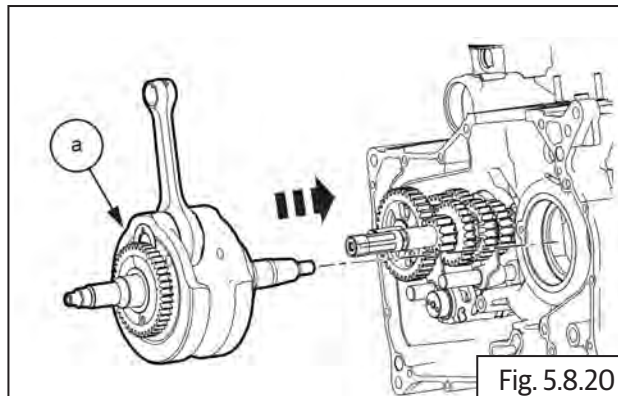

5.3.6. Balancer Shaft

- Install balancer shaft (a) on the LH crankcase .

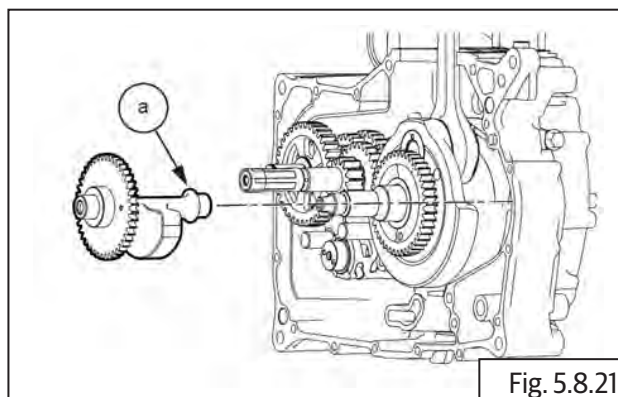

- Ensure that three punch mark (a) on the crankshaft gear and balancer shaft are matching.
- Ensure both the gears are meshed correctly.

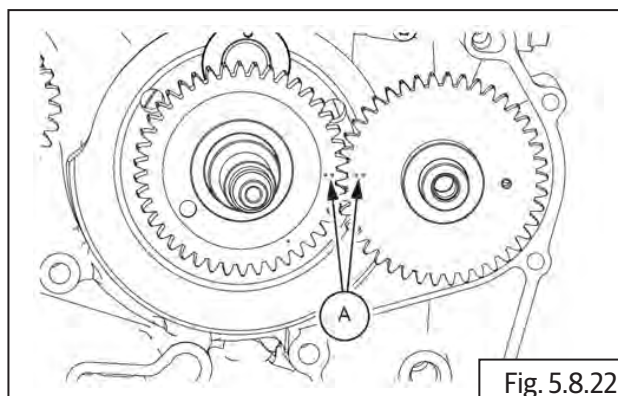

5.3.7. Dowel pins

- Insert 2 nos hollow dowel pins (**a**) in the crankcase

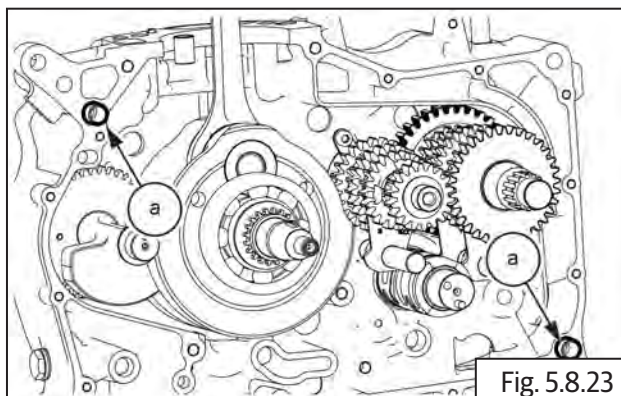

5.3.8. Crankcase Closing

- Support LH crankcase assembly firmly on suitable wedges with the mating surface facing up.

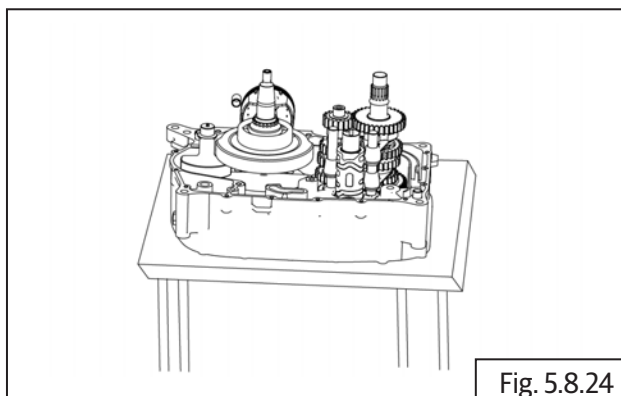

NOTE

- Ensure the mating space both the crankcase are clean and dry.

- Apply recommended silicon gasket on the mating surface of the crankcase.
- Align the RH case over the LH case and fix it by tapping gently using mallet.

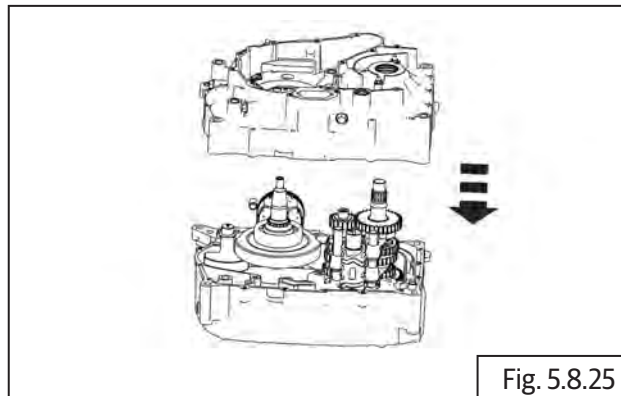

5.3.9. Crankcase Bolts Tightening Procedure

CAUTION

Ensure the gear shift forks are not jammed in the grooves in the gears.
Crankcase bolts and washers are non reusable

- Tighten the crankcase bolts in the following sequence mentioned below,

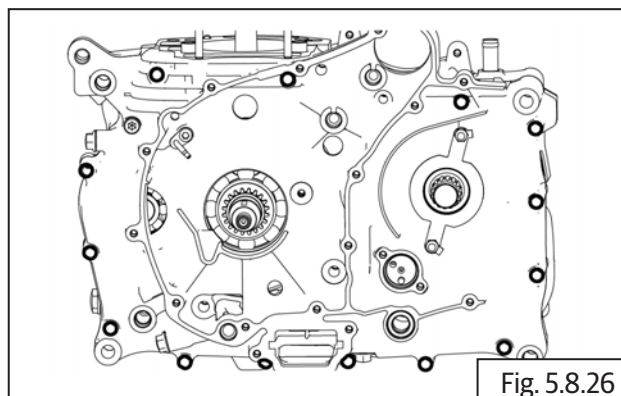

5.3.10. Piston and Piston Rings

NOTE

- Lubricate piston rings with engine oil before installation

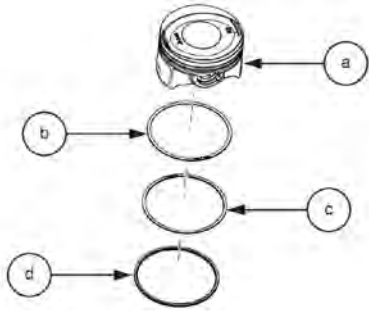

Fig. 5.8.27

a	Piston
b	Top Ring
c	Second Ring
d	Oil Ring

Rings Orientation Pattern

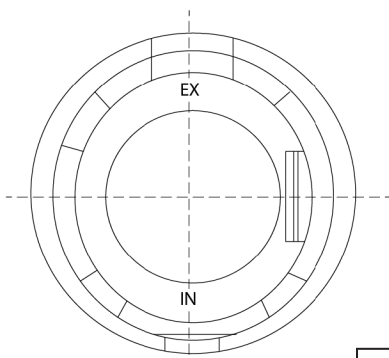

Fig. 5.8.28

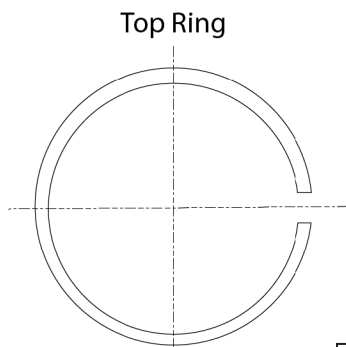

Fig. 5.8.29

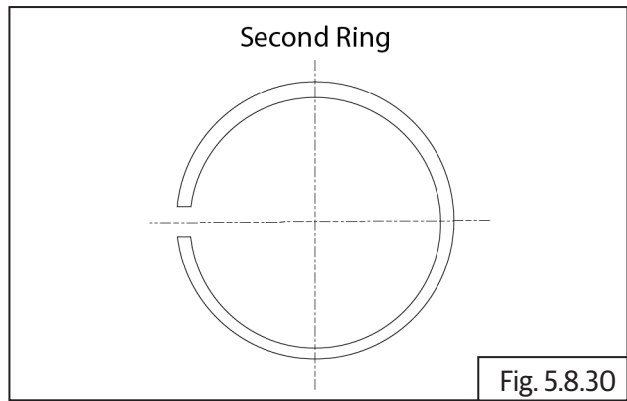

Fig. 5.8.30

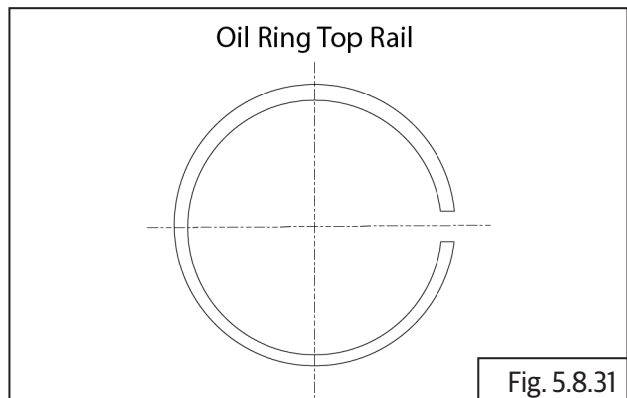

Fig. 5.8.31

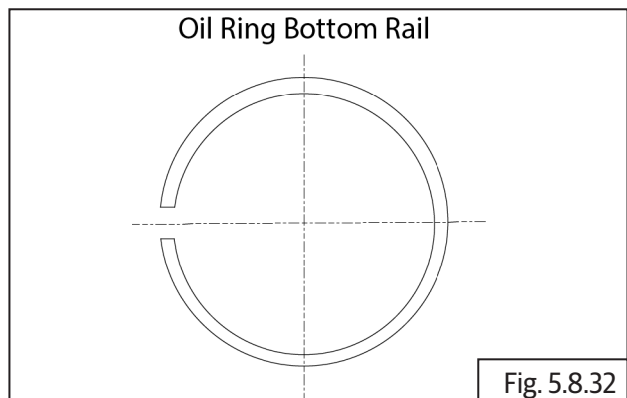

Fig. 5.8.32

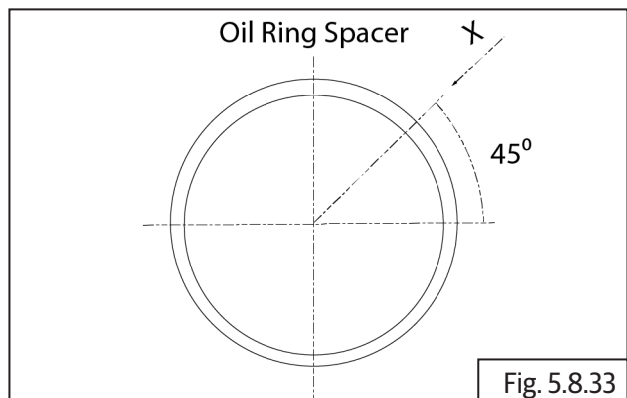

Fig. 5.8.33

Piston

NOTE

- Ensure to cover the crankcase opening below the piston with a clean and dry cloth to avoid the circlip falling into the crankcase.
- Apply engine oil on piston pin before installation.

- Install circlip in piston RH
- Install piston using gudgeon pin **(a)** in the connecting rod.

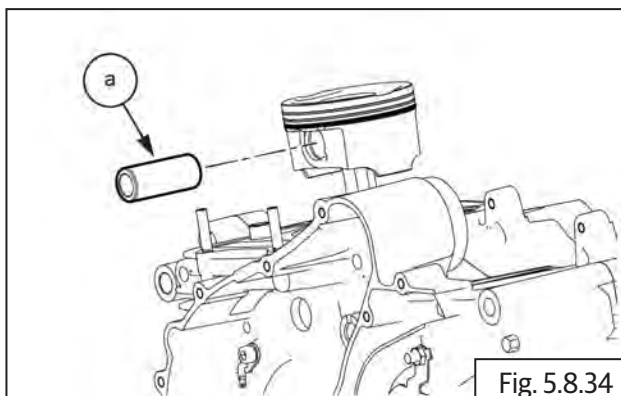

- Install circlip **(a)** on piston LH.

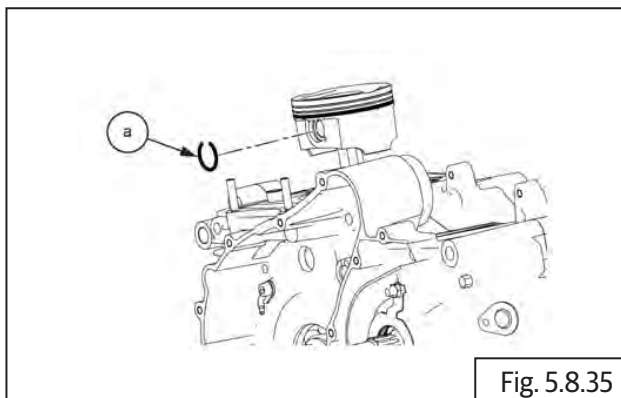

Connector

5.3.11. Cylinder Barrel

NOTE

- Ensure the gasket seating area in the crankcase is clean.

- Assemble 2 nos dowel pin **(a)** into cylinder barrel.

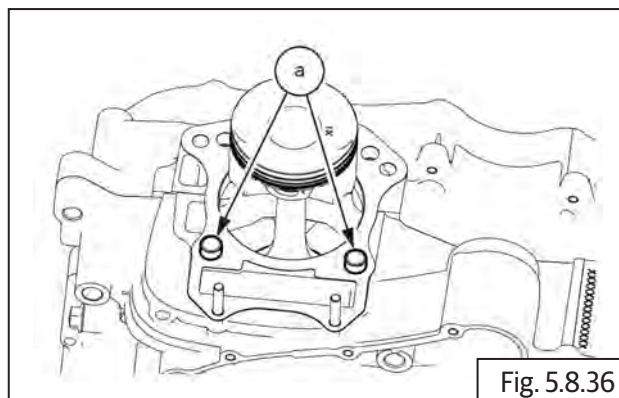

Nose Plier

NOTE

- Apply a thin coat of engine oil around the cylinder barrel before installing piston

- Install new cylinder barrel gasket **(a)** on the crankcase by aligning to the two dowel pins.

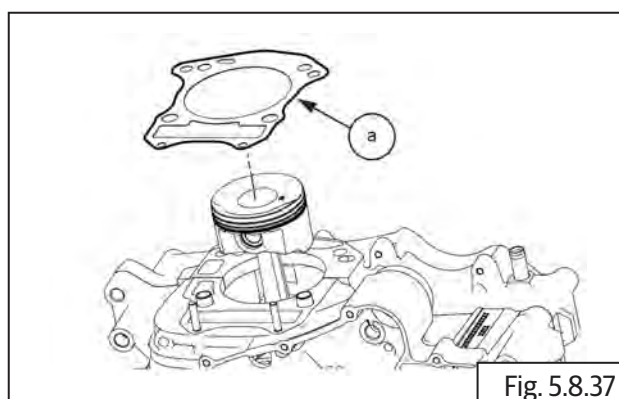

- Install the cylinder barrel **(a)** on the crankcase **(b)**.

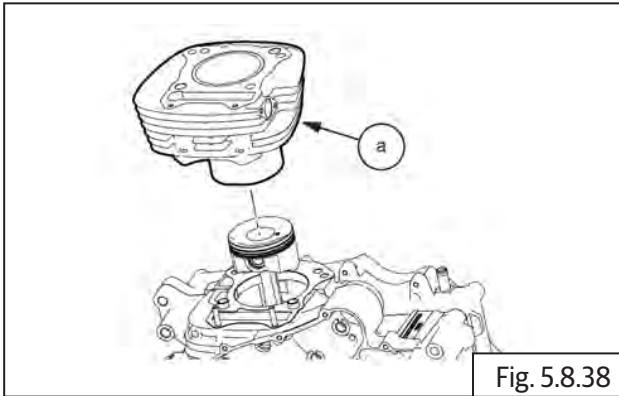

- Install the 2 Nos. cylinder barrel bolts **(a)**.

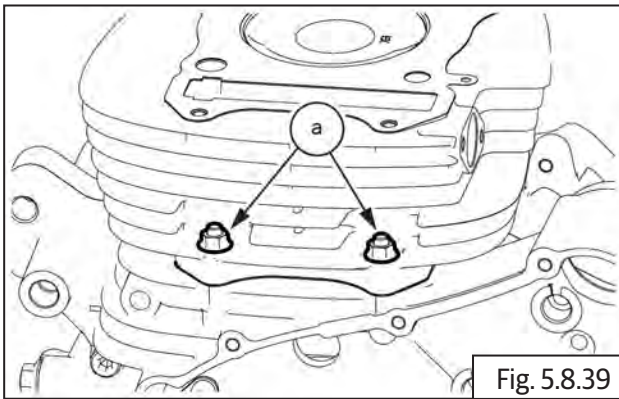

5.3.12. Valves and Springs

- Install 2 Nos. valve stem seals **(a)** on the 2 Nos. valve guides **(b)**.

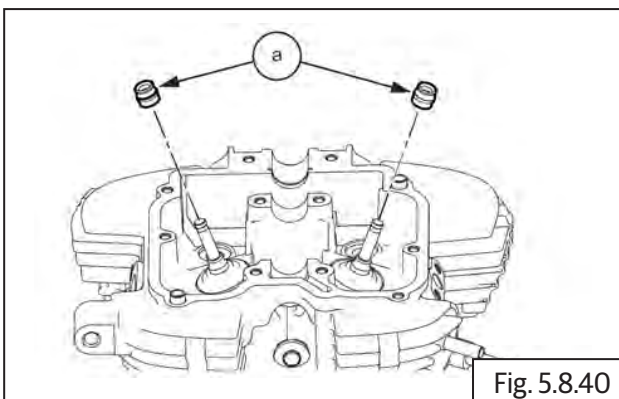

NOTE

- Lubricate valve stem with engine oil before installation.

- Lubricate and install the corresponding valve **(a)** in the cylinder head **(b)** valve guide from bottom.

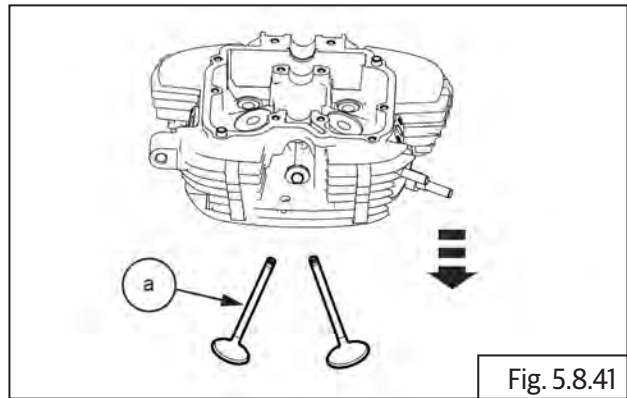

- Support the valve from bottom and install valve spring seat and spring **(a)** on valve stem **(b)** from top.

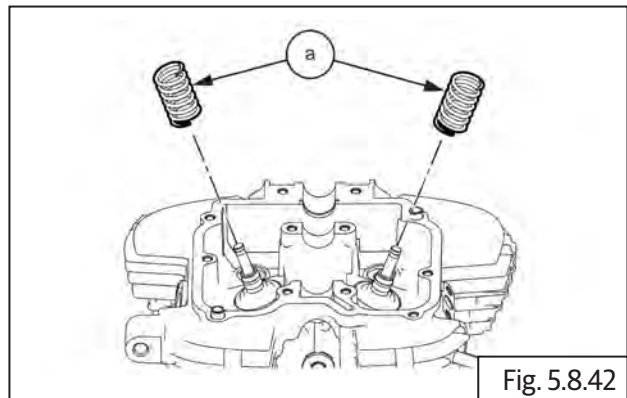

- Install retainer on the spring.

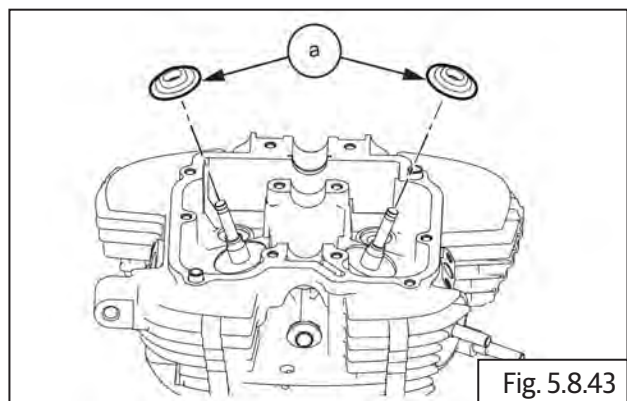

⚠ CAUTION

During installation ensure the closed coil position in spring is facing downwards

- Insert a special tool **(b)** and compress valve spring **(a)** and “hand tighten” the threaded screw.

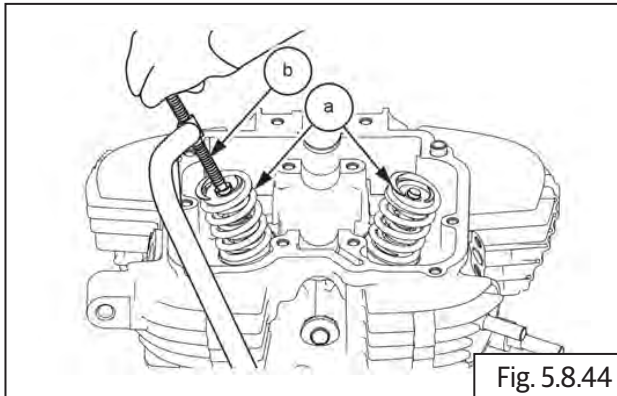

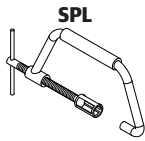
	Part No: ST-27528-2
	Part Name: Valve spring compressor

⚠ CAUTION
Never over tighten the special tool screw or it will damage both the valve seating surface and the special tool.

- Insert cotter **(a)** on the valve stem top portion.

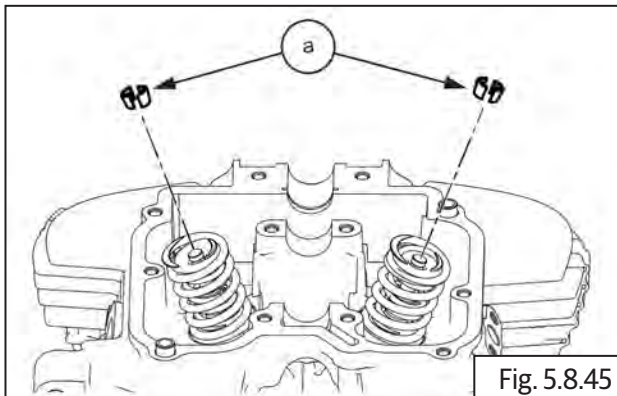

- Gently unscrew special tool **(a)** screw and remove from the valve spring **(b)**.

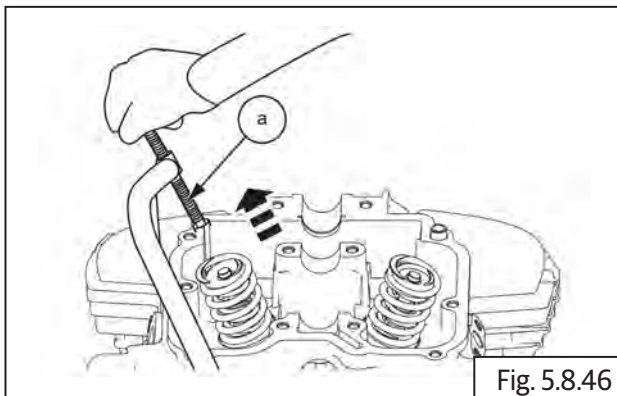

- Repeat the above process for another valve.

5.3.13. Cylinder Head

- Locate new head gasket **(a)** along with the dowel pin on the cylinder barrel.
- Ensure head gasket orientation to be matching the oil hole position.

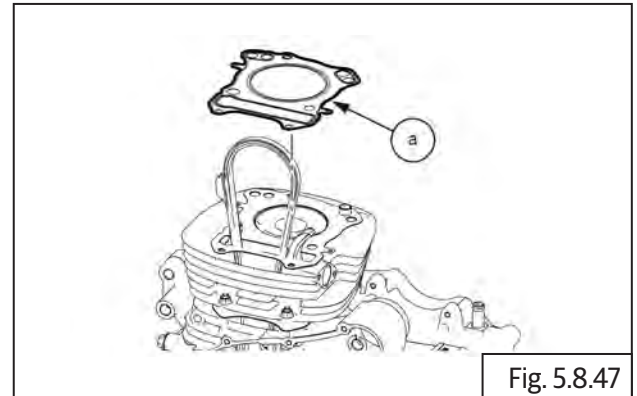

- Align the cylinder head assembly to the dowel pin 2 nos **(a)** on the cylinder barrel.

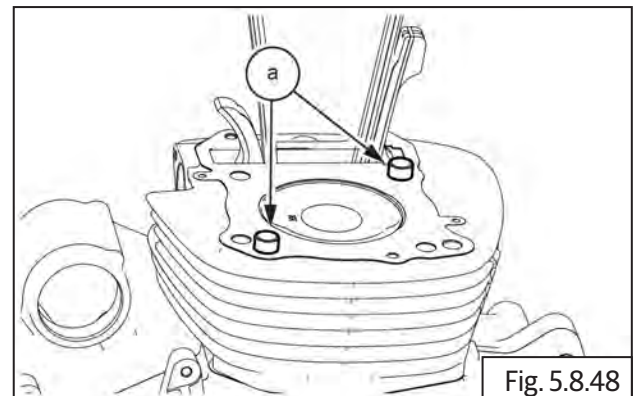

NOTE

- *Cylinder Head Bolts and washers **M10** are **NON REUSABLE**.*
- *Apply engine oil to the threads of the bolt before installation.*

- Install the cylinder head **(a)** over cylinder barrel.

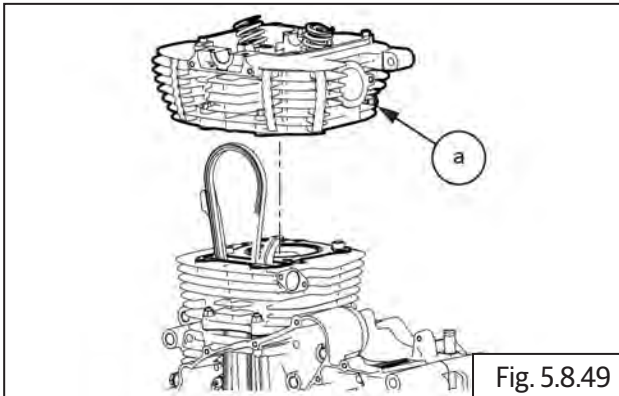

Fig. 5.8.49

- Install cylinder head bolts **(M10) (a)** 4 Nos. along with washers.

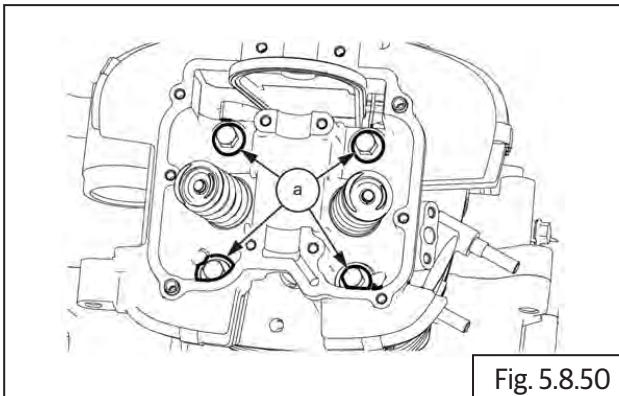



Fig. 5.8.50

	12 mm Socket with Ratchet
Torque	20-25 N-m/2.0-2.5 kgf-m

- Locate and install 2Nos **(M6) (a)** bolts on cylinder head assembly.

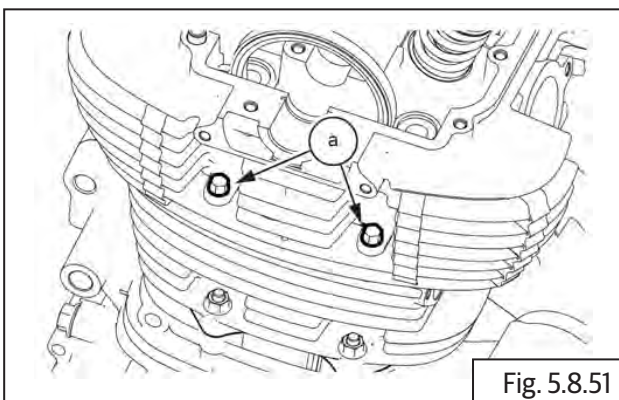



Fig. 5.8.51

	8 mm Socket with Ratchet
Torque	8-12 N-m/0.8-1.2 kgf-m

5.3.14. Timing chain on Crankshaft

- Install the tensioner pad **(a)** on the crankcase groove using a bolt **(M6)**.

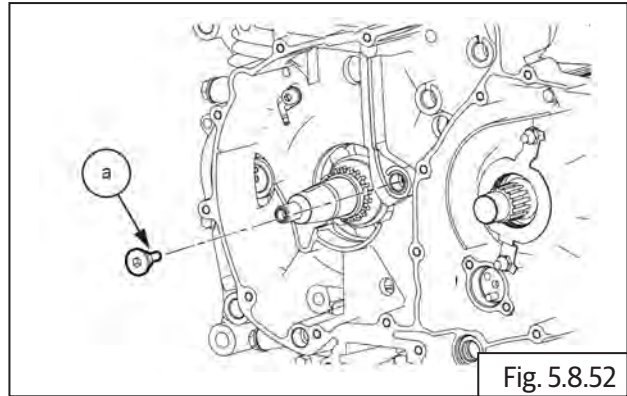



Fig. 5.8.52

	8 mm Socket with Ratchet
Torque	8-12 N-m/0.8-1.2 kgf-m

- Install timing chain front pad **(a)** by pressing and locking.

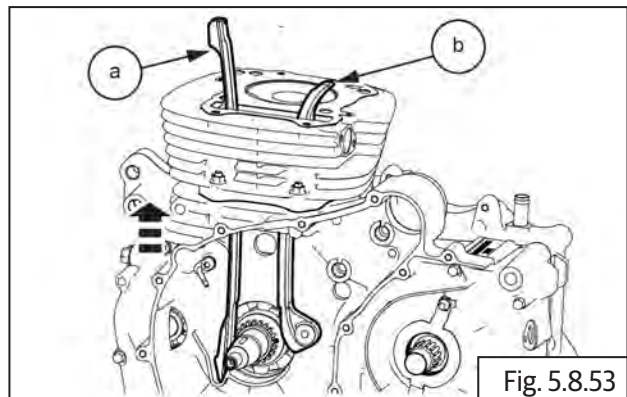

Fig. 5.8.53

- Install timing chain **(a)** on the crankshaft.

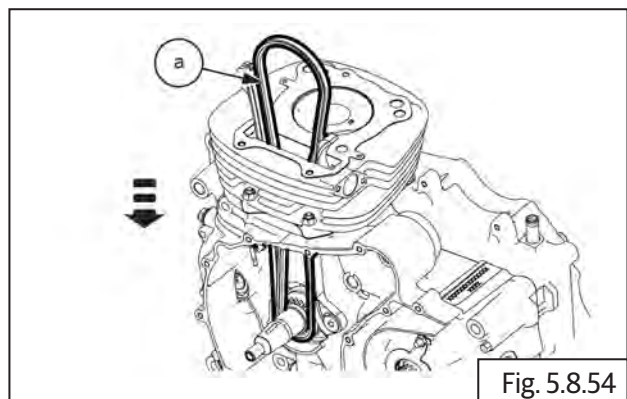
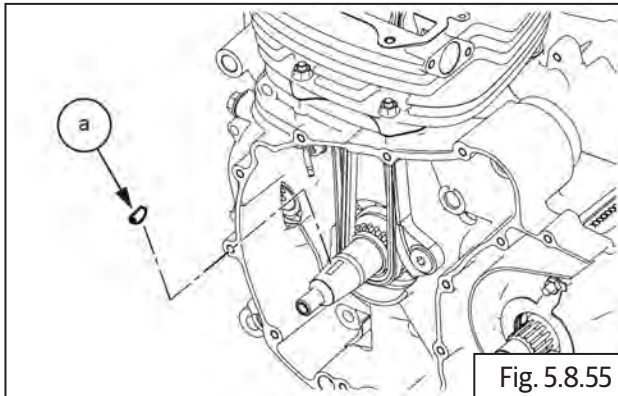

Fig. 5.8.54

5.3.15. Woodruff Key on Crankshaft

- Assemble woodruff key **(a)** on crankshaft and ensure it is facing upwards by rotating crankshaft.



- Install gear starter clutch **(a)** into magneto rotor **(b)** by simultaneously rotating and pushing.

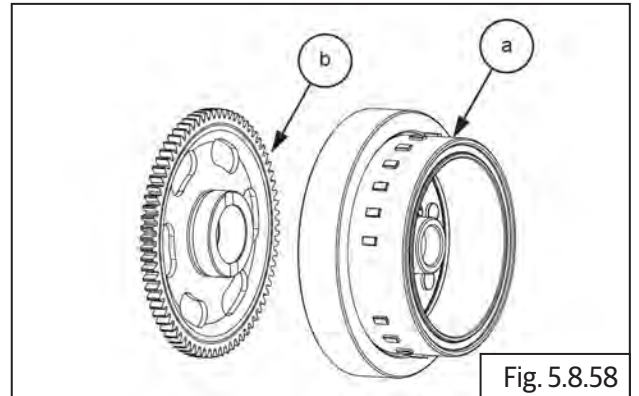

5.3.16. Magneto Rotor on Crankcase

NOTE

- Lubricate starter clutch with engine oil before installation.
- Install starter clutch with outer ring **(a)** into magneto rotor **(b)** using **(M6)** bolts.

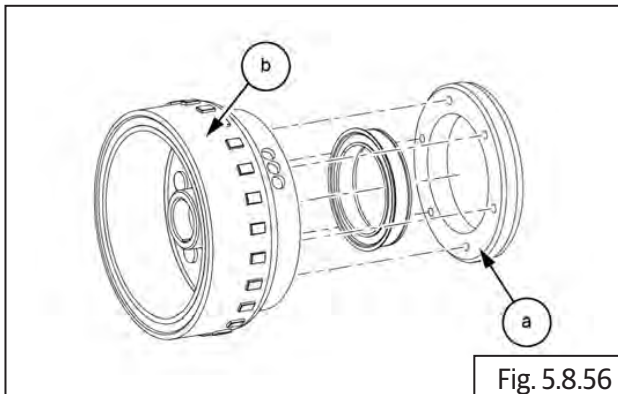

- Locate magneto rotor **(a)** on crankshaft. Ensure the slot provided in the rotor is aligned with woodruff key.

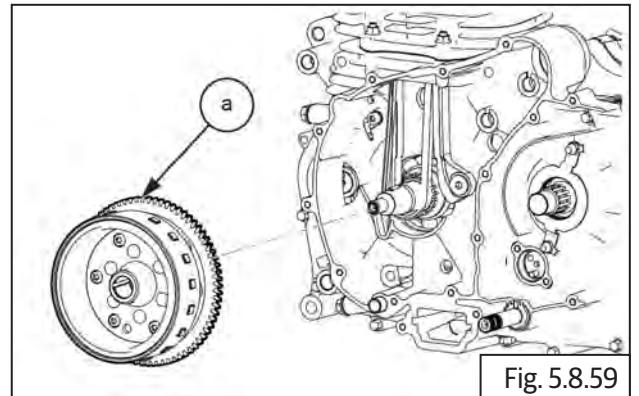

- Install hex flange bolt **(M6)** on magneto rotor.

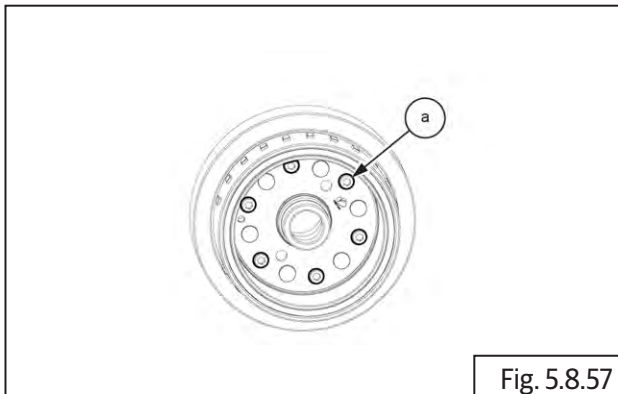

- Locate and install hex flange nut **(a) (M12)** on magneto rotor with washer.

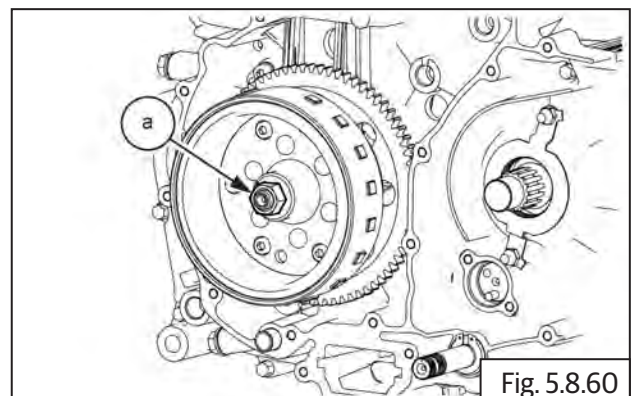

	5 mm Allen Socket with Ratchet
Torque	10-12 N-m/1.0-1.2 kgf-m

	17 mm Socket with Ratchet
Torque	45-55 N-m/4.5-5.5 kgf-m

NOTE

- Ensure Crankshaft & Magneto taper free from oil & foreign particles.
- Taper surfaces has to be cleaned with Isopropyl solution before assembly

5.3.17. Camshaft Assembly

NOTE

- Lubricate camshaft lobe and journals with engine oil before installation.

- Hold the timing chain (a) in stretched condition and gently rotate crankshaft clockwise in order to bring piston in TDC.

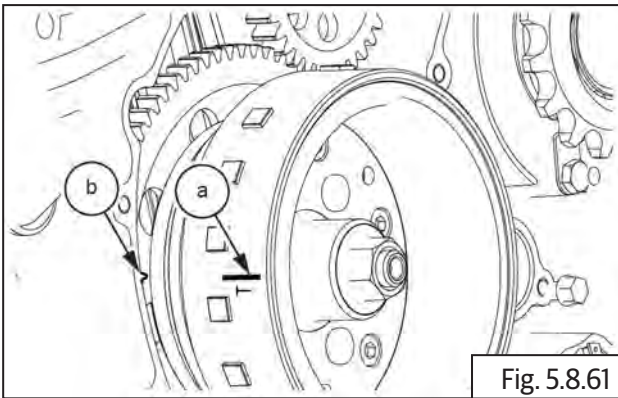

NOTE

- Lock the crankshaft using the special tool from crankcase RH.

! CAUTION

Do not rotate crankshaft anti-clockwise

- Install camshaft assembly (a) on cylinder head.

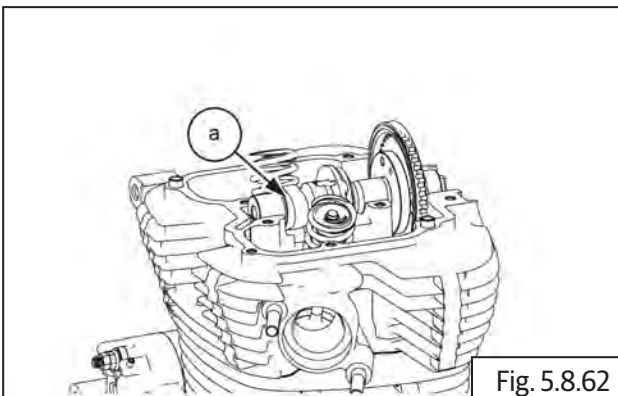

- Install C washer (a) on cylinder head (b).

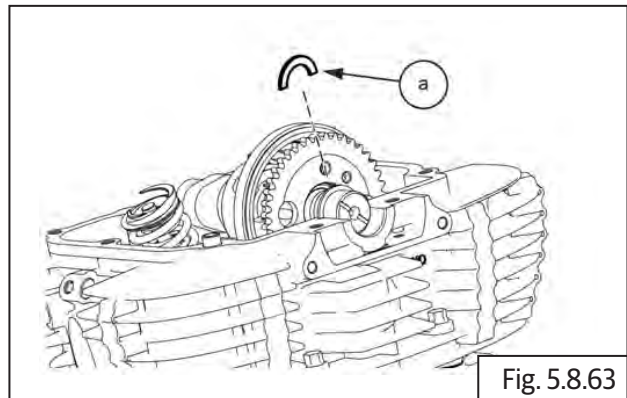

- Install cam chain (b) on the camshaft sprocket (a).

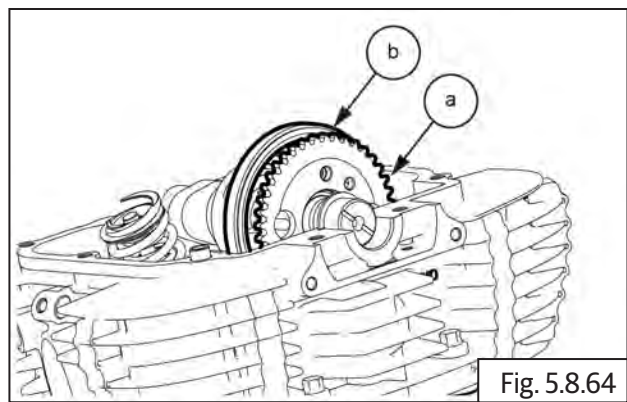

- Locate 1 Nos. bolts (M6) (a) on camshaft sprocket

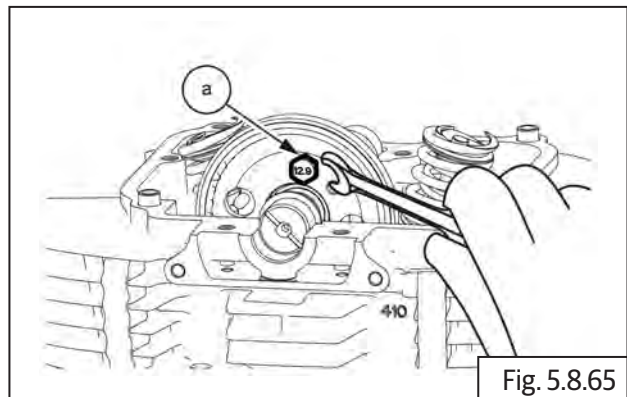

8 mm Socket with Ratchet

Torque

10-12 N-m/1.0-1.2 kgf-m

- Rotate crankshaft in order to access the second bolt (a) on camshaft sprocket

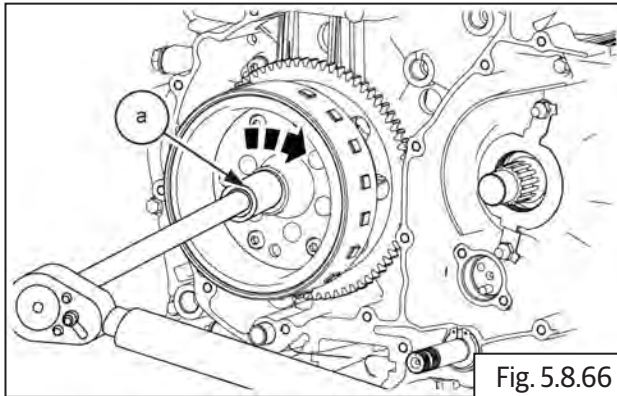

Fig. 5.8.66

- Locate 1 Nos. bolts (M6) (a) on camshaft sprocket

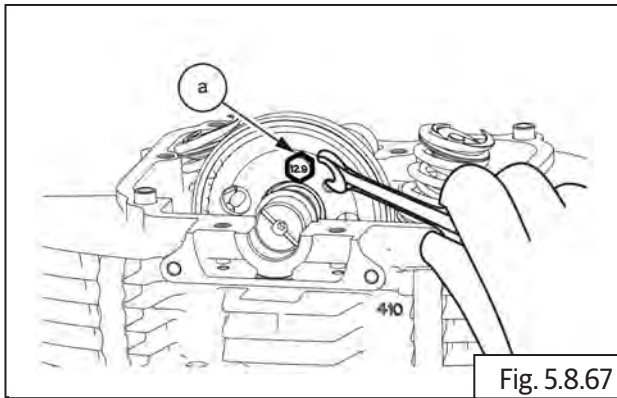

Fig. 5.8.67

	8 mm Socket with Ratchet
Torque	10-12 N-m/1.0-1.2 kgf-m

5.3.18. Rocker Carrier in Cylinder Head

⚠ CAUTION

Ensure the rocker shaft assy direction, Minus shape slot & M6 tap should be facing outside

⚠ CAUTION

Ensure rocker shaft is assembles in the corresponding inlet and exhaust sides as dismantled.

NOTE

- Lubricate rocker arm and rocker arm shafts with engine oil before installation.

- Align the rocker carrier assembly (a) on the cylinder head.

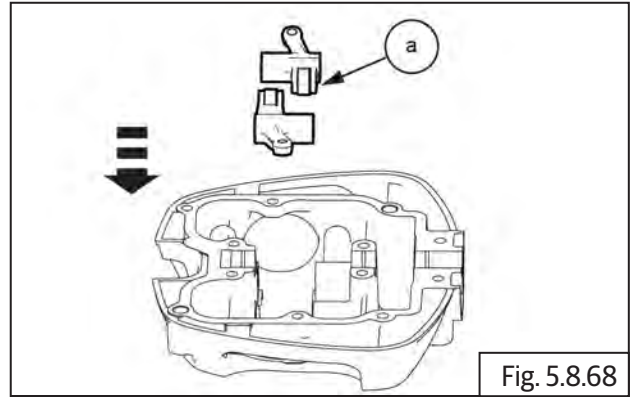

Fig. 5.8.68

⚠ CAUTION

Rocker carrier bolts are one time use only. DO NOT reuse.

- Align rocker arm in carrier (a) and insert spindles (b) in carrier.

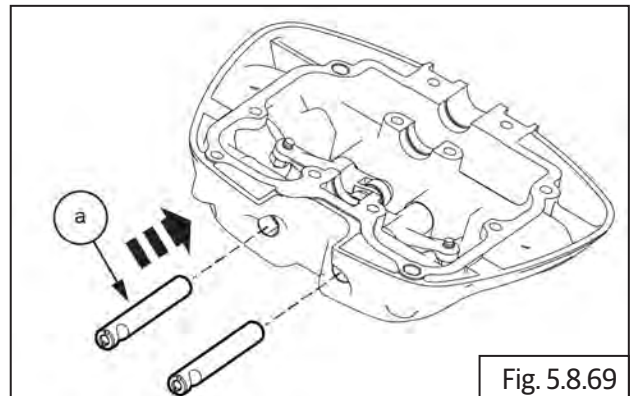

Fig. 5.8.69

- Lock the crank gear using special tool (a).

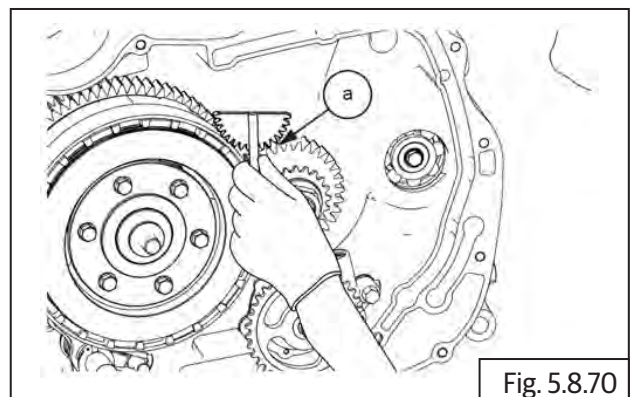
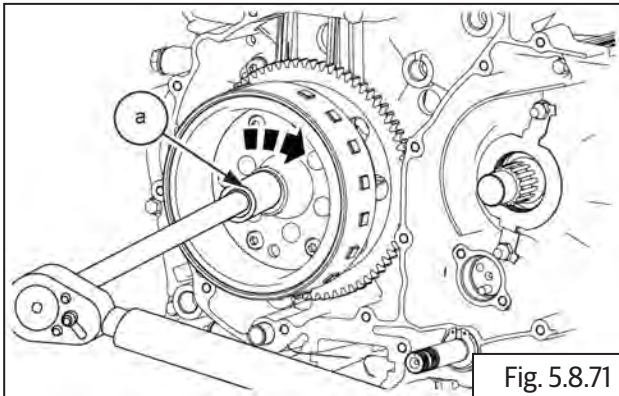
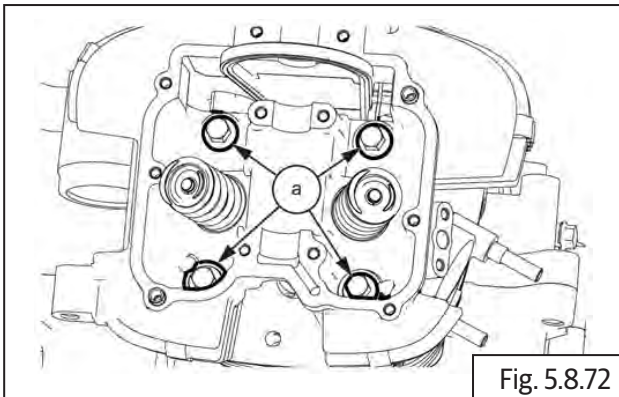



Fig. 5.8.70

- Gently rotate the crankshaft and insert the special tool **(a)** on crankcase RH to lock the crankshaft.



- Install 4 Nos. bolts **(M6) (a)** on rocker carrier in crisscross pattern. Apply engine oil on the threads of the bolt before installation



	8 mm Socket with Ratchet
Torque	10-12 N-m/1.0-1.2 kgf-m

5.3.19. Tappet Clearance Adjustment

- Align the magneto "T" mark **(a)** with the marking **(b)** in the crank case to set TDC.

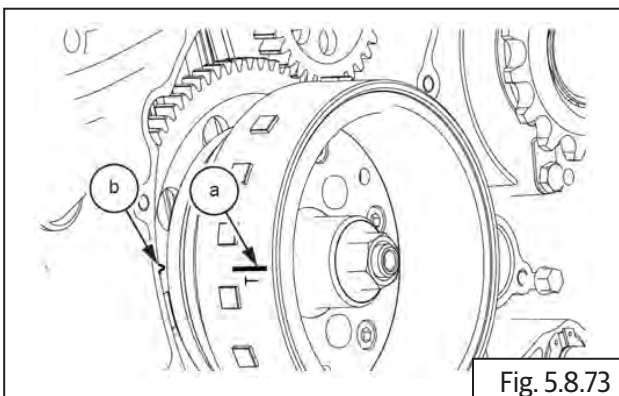

- Loosen tappet adjuster locknut with special tool.

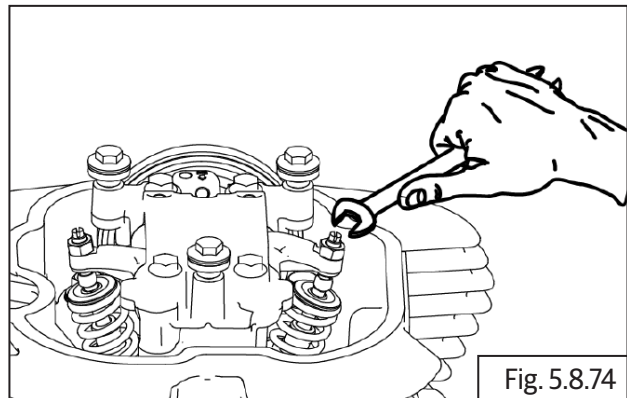

- Insert a screwdriver into the tappet adjusting tool and ensure it is seated correctly on the adjuster screw.

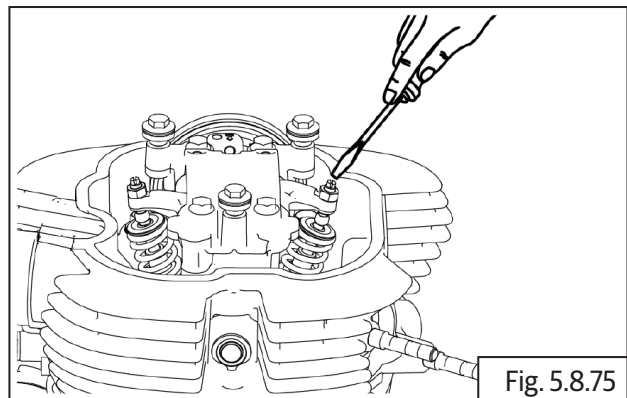

- Insert feeler strip between adjuster screw and valve stem as per thickness mentioned below.

For intake - 0.08 mm

For exhaust - 0.18mm

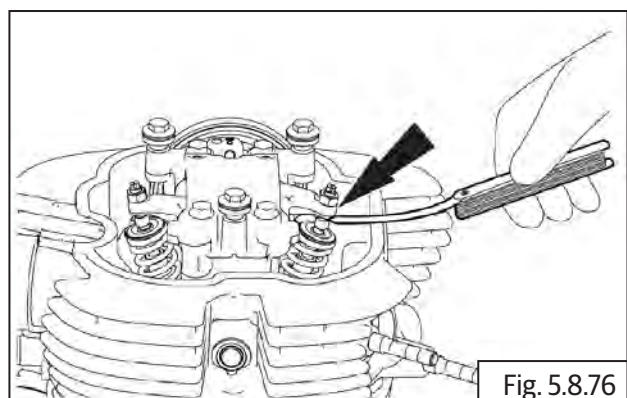

- Gently pull out feeler strip (a) and check if it comes out freely OR with resistance.
- If feeler strip comes out freely tighten the adjuster screw.
- If feeler strip movement is hard loosen the adjuster screw.
- Adjust the screw using screwdriver simultaneously to check the correct and smooth movement of feeler strip.
- After adjusting the tappet remove feeler strip and gently lock the lock nut against rocker arm using the special tool.
- Remove screw driver and both special tools.

NOTE	
<i>Check tappet clearances one more time before locking the lock nut</i>	

⚠ CAUTION	
Do not adjust tappets with less OR no clearance as it will result in poor compression, valve burn-out and wear-out of tappet adjuster foot. Do not adjust tappet with high clearance as will result in noise and insufficient opening of the valves	

5.3.20. Cylinder Head Cover

NOTE	
<ul style="list-style-type: none"> • Ensure the cylinder head cover surface and gasket seating groove are clean. • Ensure sealant is applied in the head gasket before assembly. 	

- Install the cylinder head (a) after applying sealant and ensure it is seated properly.

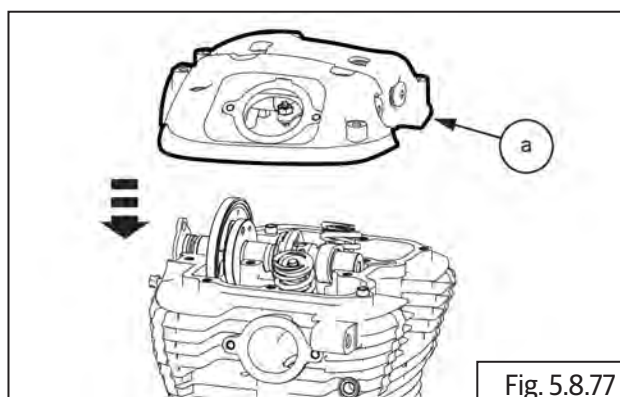

- Install cylinder head cover using new seals, washers and 3 Nos. bolts (a) (M6).

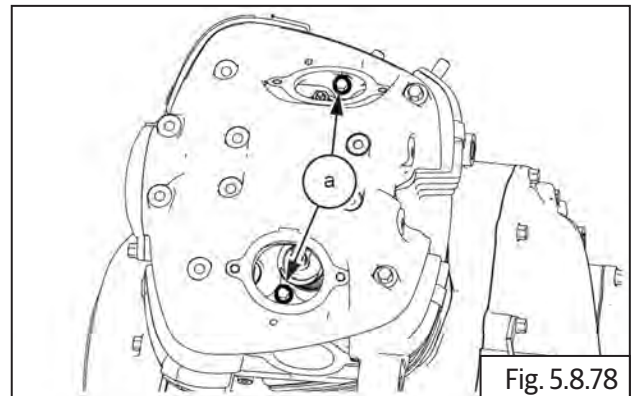

	8 mm Socket with Torque Wrench
Torque	10-12 N-m/1.0-1.2 kgf-m

- Install 2 Nos .hex bolts (M6) (a) onRH side.

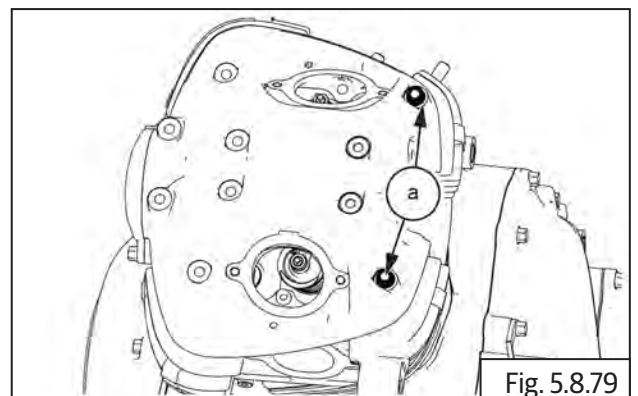

- Install 2 Nos .hex bolts (M6) (a) from RH side.

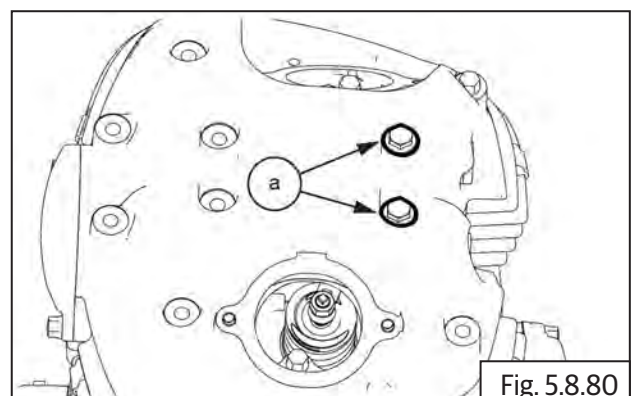

- Install 2 Nos .hex bolts **(M6) (a)** from LH side.

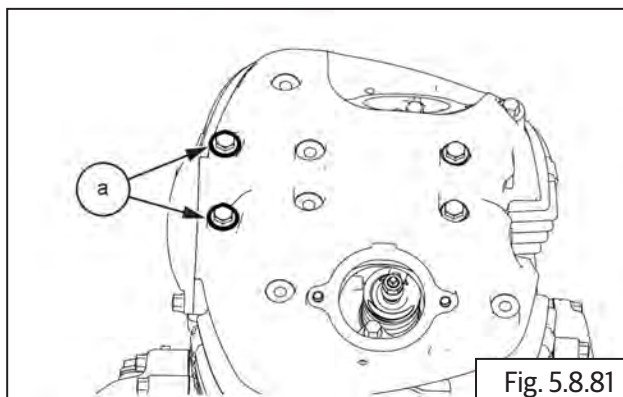

- Install 2 Nos. Hex flange head bolts **(M6) (a)** along with rubber seals and washers from RH side

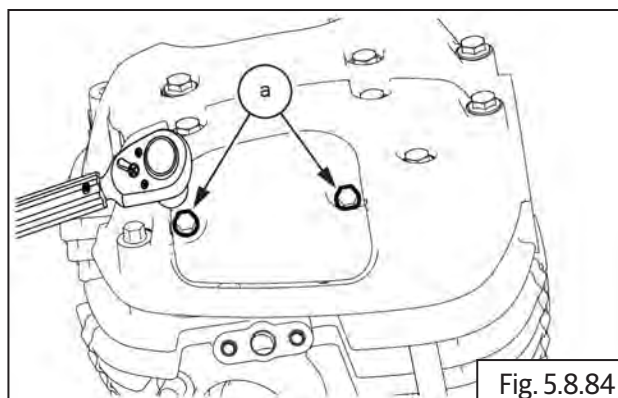

- Install 4 Nos .hex length bolts **(M6) (a)** from LH side.

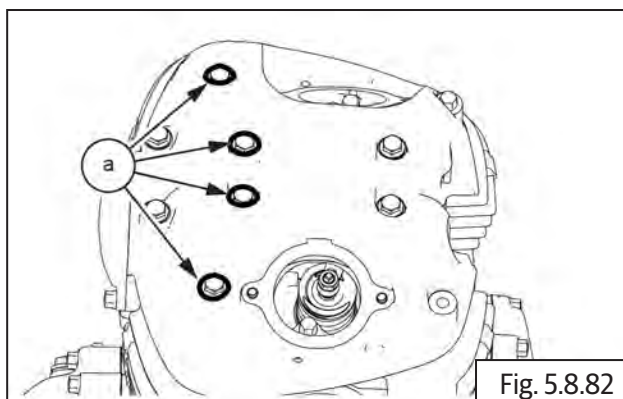

- Install the valve cover **(a)** along with the O-ring **(b)**.

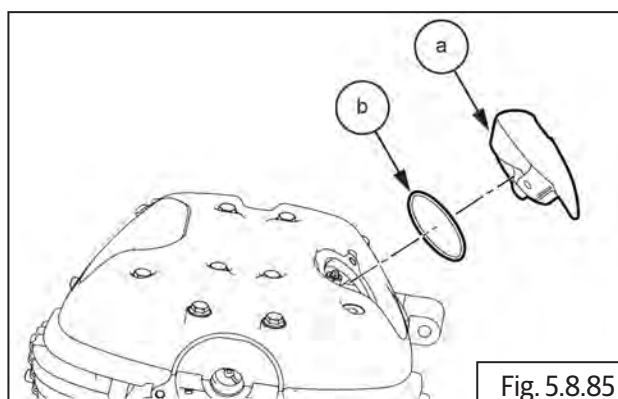

- Install the valve cover **(a)** along with the O-ring **(b)**.

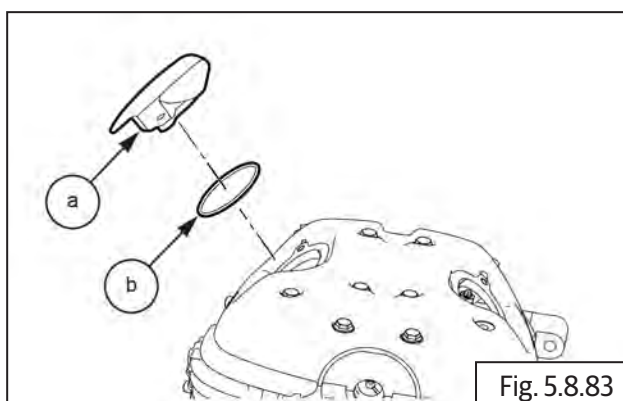

5.3.21. Spark Plug

- Install spark plug **(a)** along with washer on cylinder head.

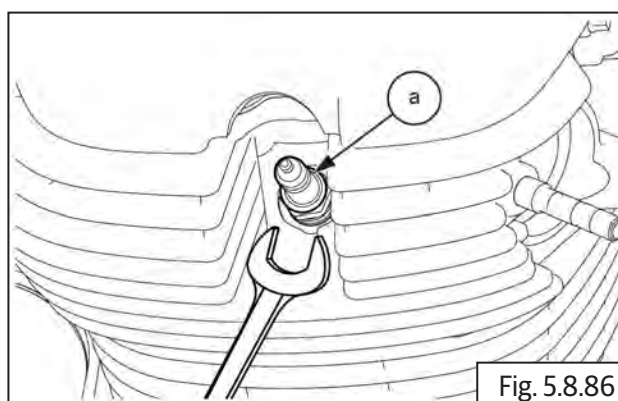

16 mm Deep Socket with Ratchet

Torque

10-12 N-m/1.0-1.2 kgf-m

5.3.22. Star Index

- Locate star index **(a)** with pins **(b)** locating on the selector drum.

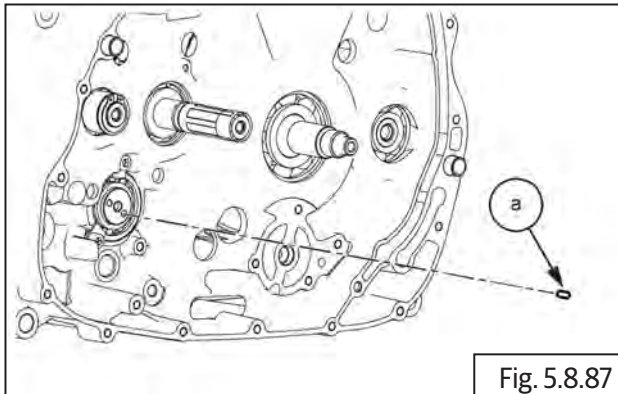

- Locate star index bolt **(a)** and tighten.

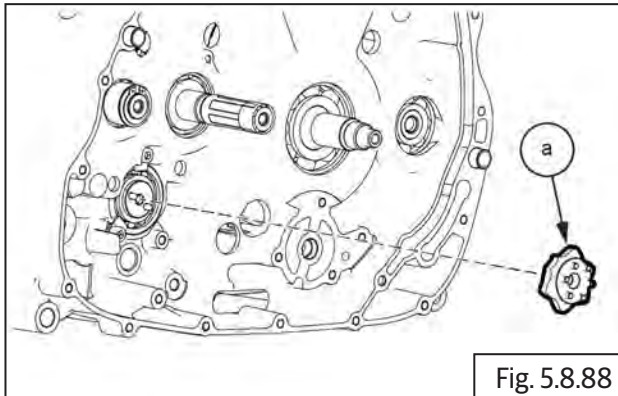

	5 mm Allen Socket with Torque Wrench
Torque	10-12 N-m/1.0-1.2 kgf-m

5.3.23. Star Index Stopper

- Locate spring **(a)** washer **(b)** and stopper arm **(c)** above spring.
- Ensure spring is seated on the groove provide in the stopper arm.

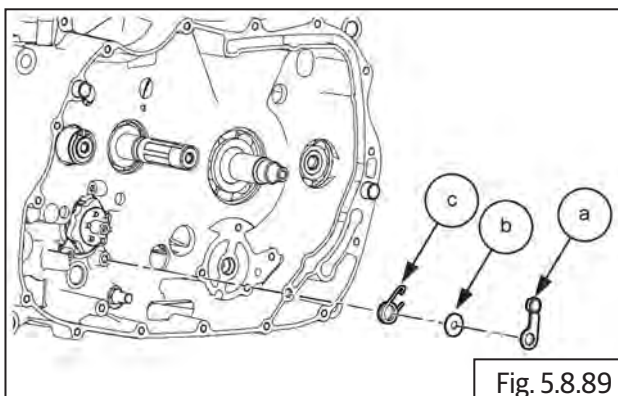

- Locate bolt **(a)** and tighten.

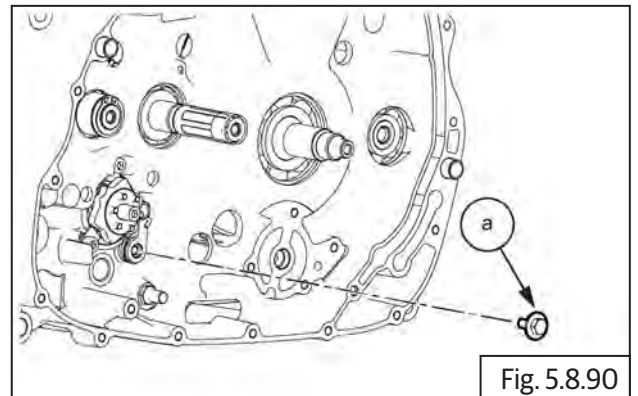

	10 mm Deep Socket with Ratchet
Torque	10-12 N-m/1.0-1.2 kgf-m

5.3.24. Gear Shifter Shaft

- Insert gear shaft **(a)** from RH side of the engine.

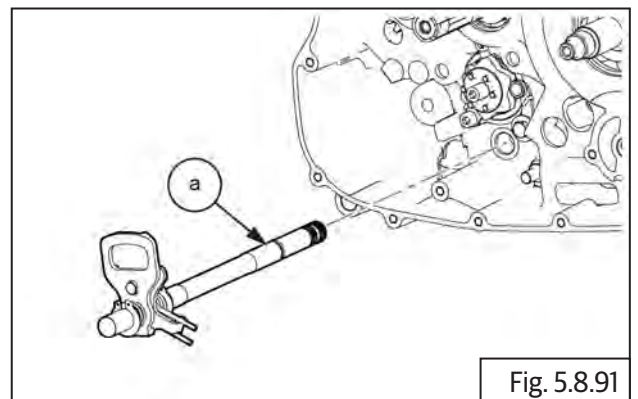

- Locate washer **(b)** and Install circlip **(a)** on shifter shaft **(a)**.

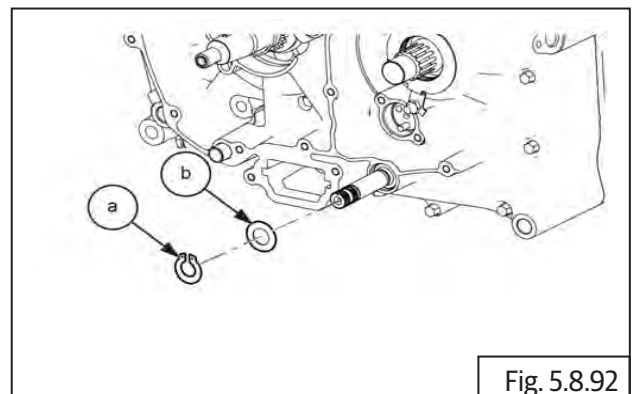

	Circlip plier
--	---------------

5.3.25. Clutch Assembly (LH thread)

- Locate spacer primary gear **(a)** on the clutch housing assembly.

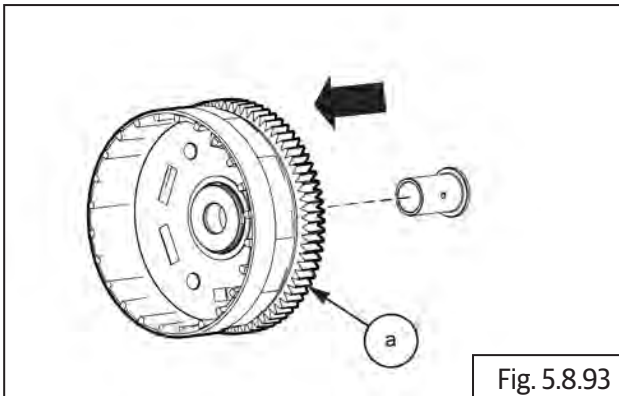

- Install the steel plates **(a)** and thrust plates **(b)** in the same order, in which those were dismantled.

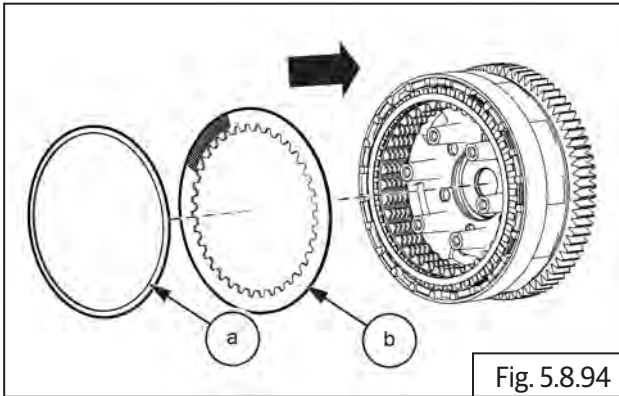

NOTE

- Last friction plate should assemble on clutch housing claw..

- Install the clutch bell **(a)** from clutch housing **(b)**.

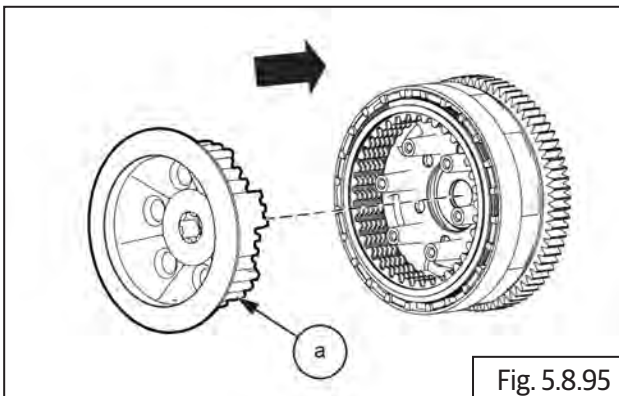

- Install six springs **(a)** from the clutch.

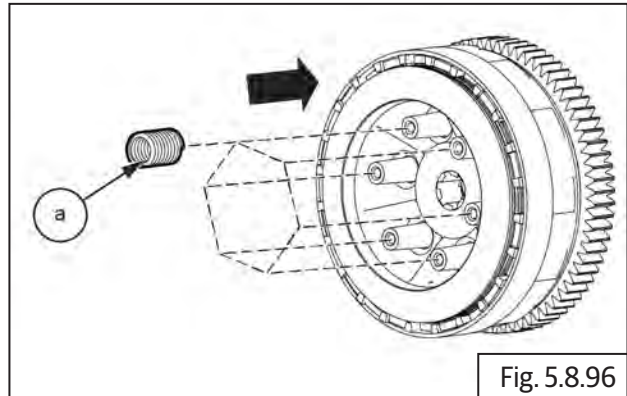

- Install pressure plate **(a)** on the clutch assembly.

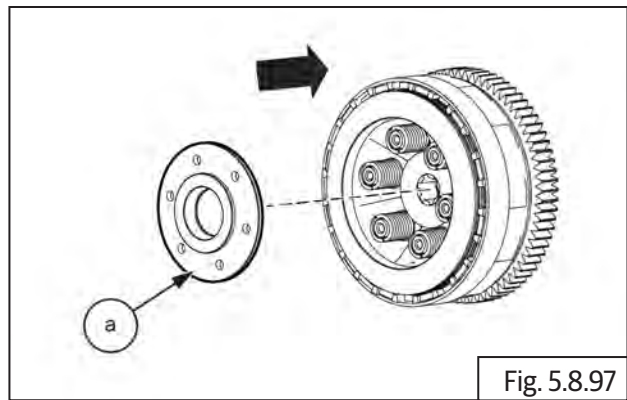

- Install the special tool **(b)** using 2 Nos. Hex bolts **(a)**

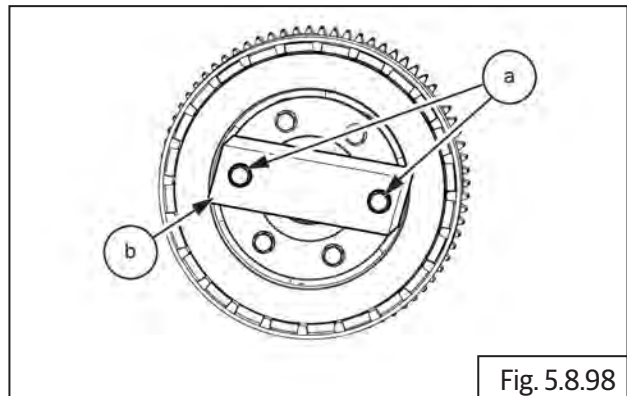

- Install 4 Nos. Hex bolts (a) along with washers to the clutch assembly.

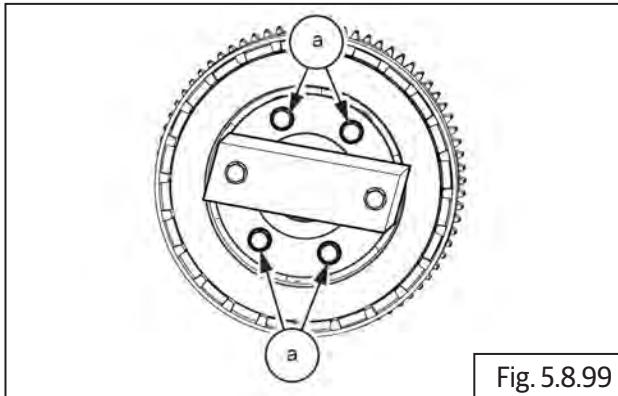

- Install the clutch assembly (a) from the counter shaft.

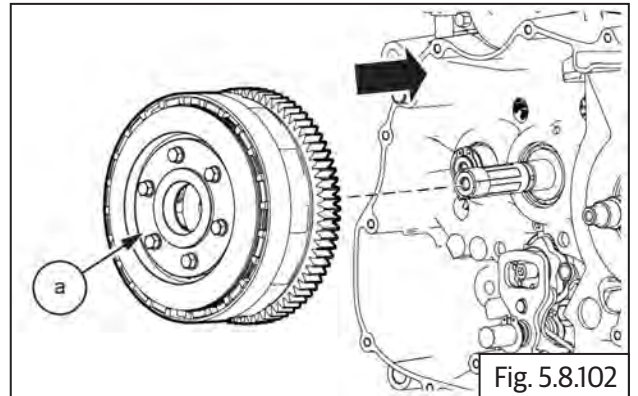

- Loosen and remove 2 Nos. Hex bolts (a) and remove the special tool (b).

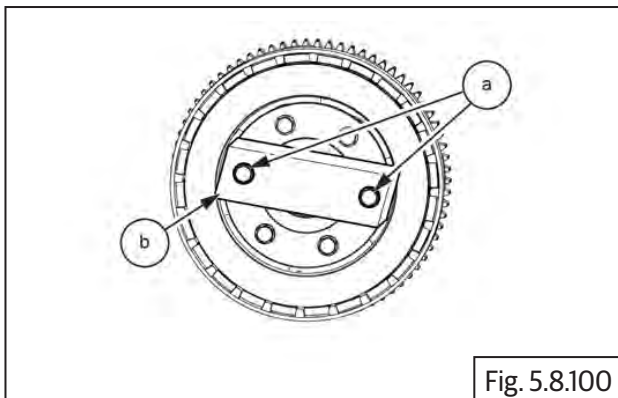

- Install tab washer and tighten the hex "U" nut (a) by locking the counter shaft using special tool.

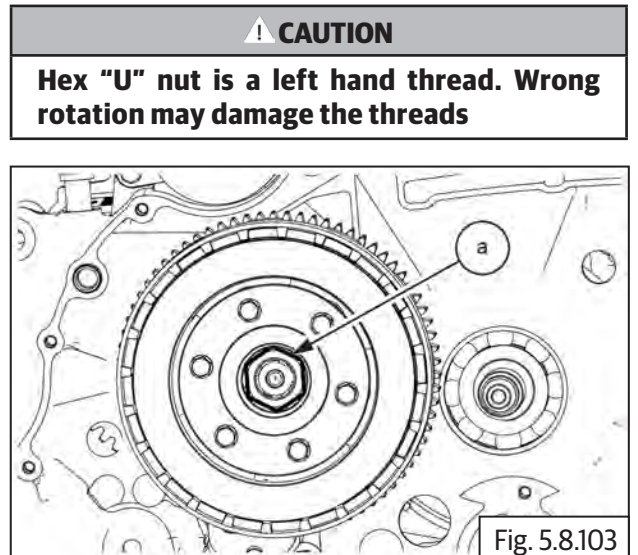

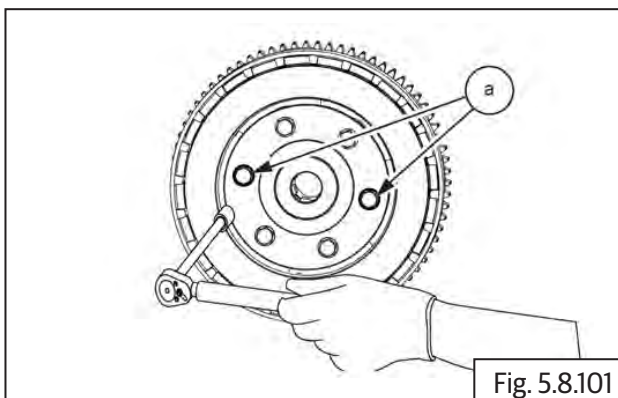

! CAUTION
Hex "U" nut is a left hand thread. Wrong rotation may damage the threads

- Install 2 Nos. Hex bolts (a) along with washers from clutch assembly.

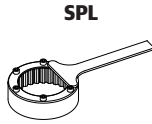

	Part No: ST275332
	Part Name: Crank Gears Locking Tool

	24 mm Socket with Ratchet
Torque	110-130 N-m/11.0-13.0 kgf-m

	8 mm Socket with Ratchet
Torque	8-12 N-m/0.8-1.2 kgf-m

- Install bearing **(a)**.

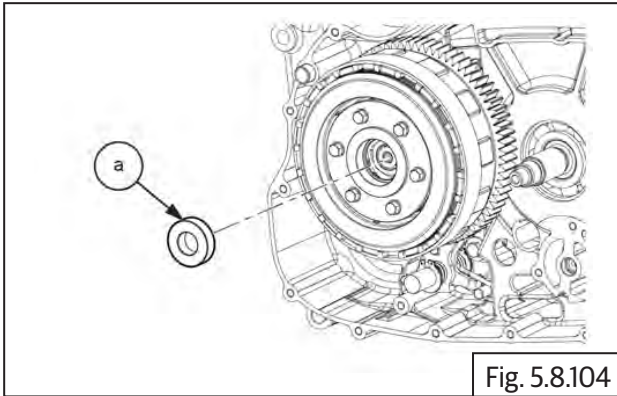

Fig. 5.8.104

5.3.26. Crank gear (LH Thread)

! CAUTION

Ensure metal grading of crank gear and clutch housing gear are the same.

- Apply engine oil and install crank gear **(b)** and washer **(a)** on the crankshaft.
- Ensure the clutch housing gear is correctly meshed with the crankshaft gear.

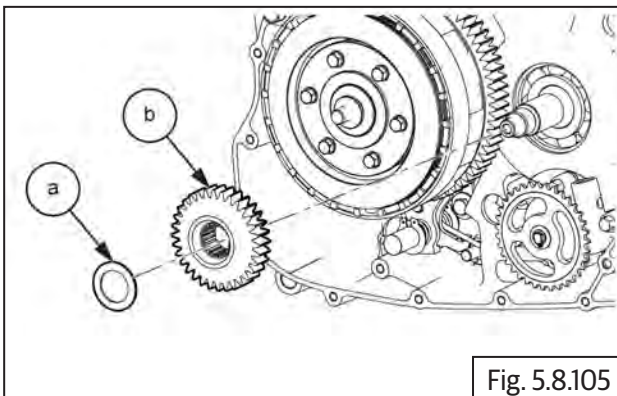

Fig. 5.8.105

- Install washer **(a)** along with oil pump drive sprocket **(b)** and Belleville washer **(c)**.
- Assemble the washer so that the OUT mark is facing the outside of the Crank gear.

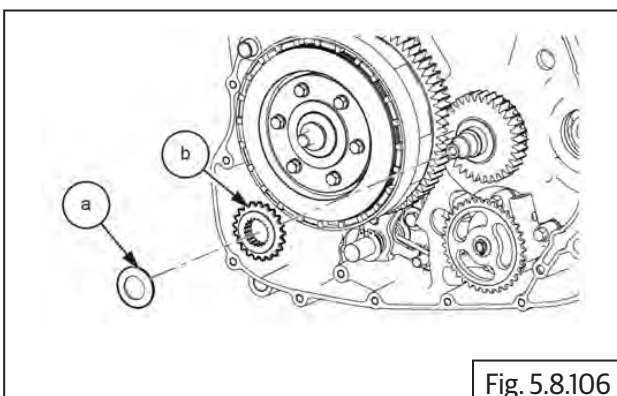

Fig. 5.8.106

- Install the oil pump chain **(a)** from the sprocket.

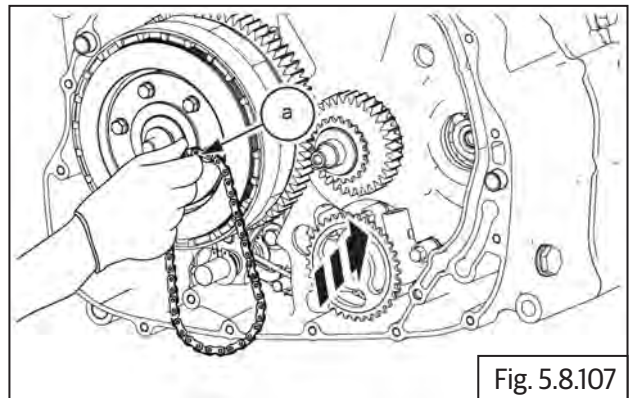

Fig. 5.8.107

- Install the crankshaft nut **(a)** on the oil pump drive sprocket by locking the gear using the special tool.

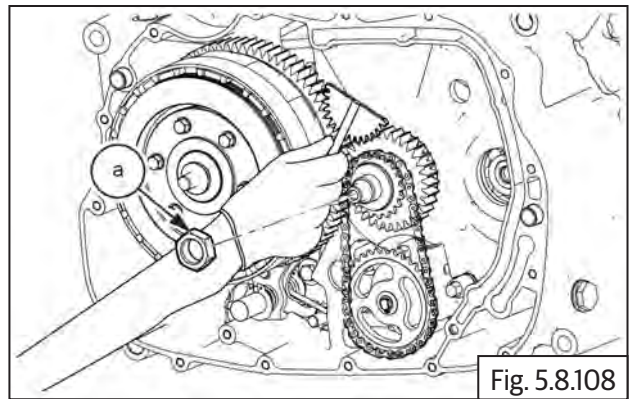
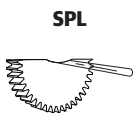



Fig. 5.8.108

	Part No: ST30922/A
	Part Name: Crank Lock Tool

	24 mm Socket with Ratchet
Torque	40-60 N-m/4.0-6.0 kgf-m

5.3.27. Balancer Shaft Bolt

- Lock the crank gear using special tool **(a)**.

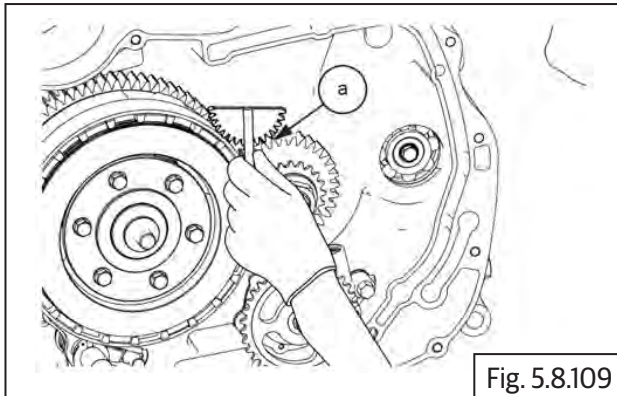

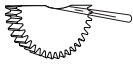
	Part No: ST30922/A
	Part Name: Crank Lock Tool

- Install 2 Nos. washers **(a)** along with bolt **(b)** to the balancer shaft and tighten it.

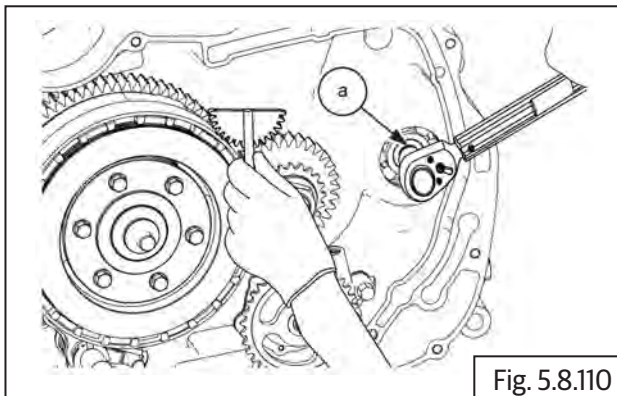

	14 mm Socket with Ratchet
Torque	40-60 N-m/4.0-6.0 kgf-m

5.3.28. Oil Pump

NOTE

- Oil pump does not have any servicable parts hence has to be replaced as an entire assembly.
- Oil pump metal gasket & O ring is one time use only. DO NOT reuse.

- Install oil pump metal gasket **(a)** along with oil pump **(b)** on the crankcase dowel.

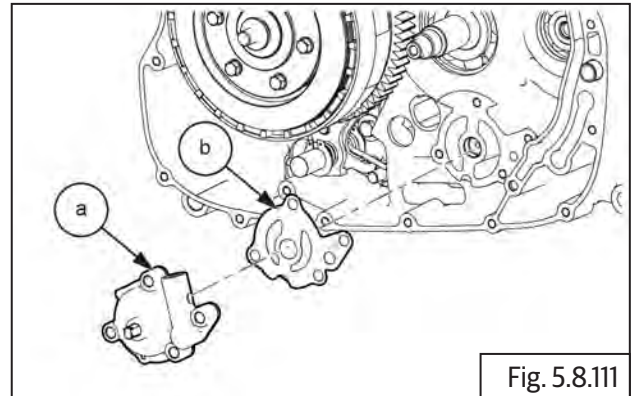

- Install 6 Nos. Hex flange head bolts **(M6)** **(a)** in crisscross pattern.

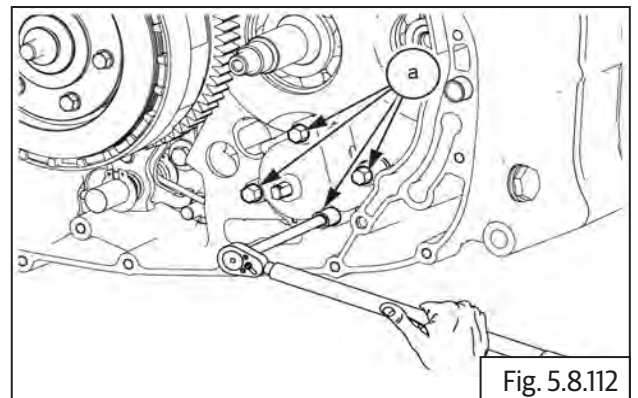

	8 mm Socket with Ratchet
Torque	8-12 N-m/0.8-1.2 kgf-m

- Install the oil pump chain **(a)** and driven sprocket **(b)** along with the washer **(c)**.

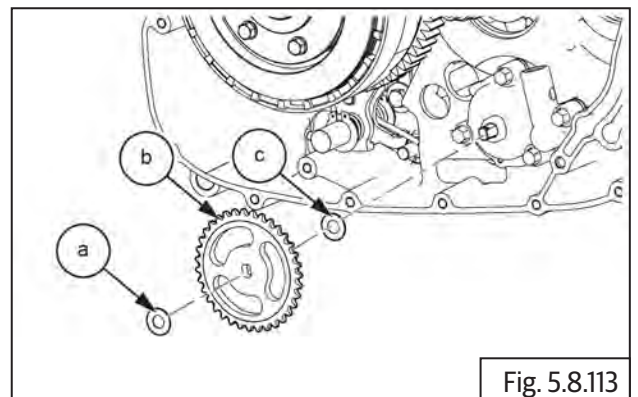

- Install circlip **(a)** on the oil pump.

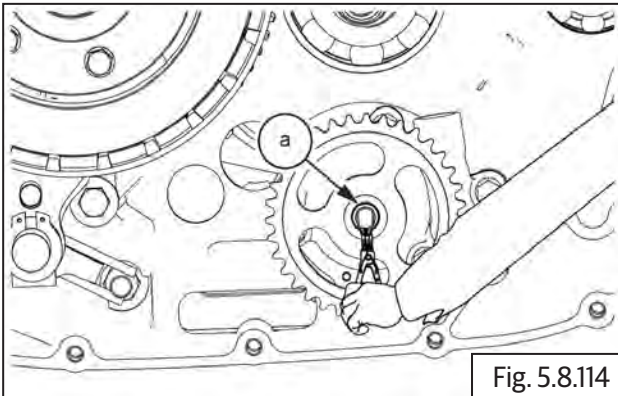

Fig. 5.8.114

5.3.29. Oil Jet

NOTE

- Ensure gearbox is in neutral condition
- Locate and tighten oil jet **(a)** into crankcase.

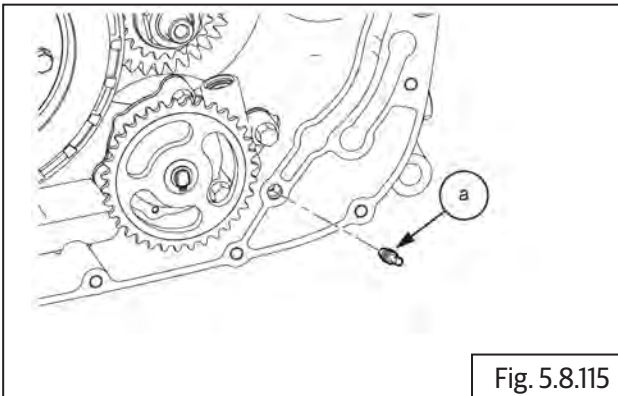



Fig. 5.8.115

	Screw Driver
Torque	0.75-1.25 N-m/0.075-0.125 kgf-m

5.3.30. Oil Level Window

- Locate oil level window inside cover LH **(a)**.

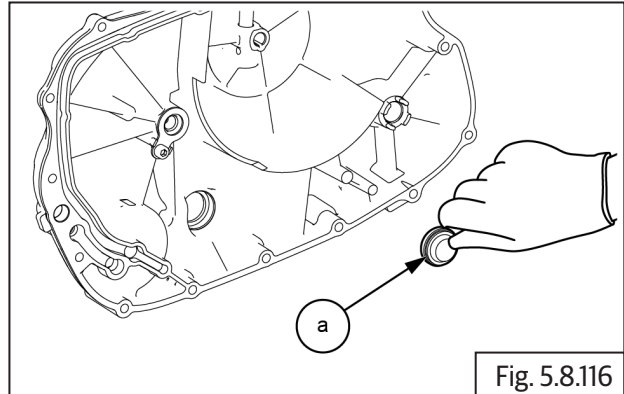

Fig. 5.8.116

- Locate circlip **(a)** in the groove provided.

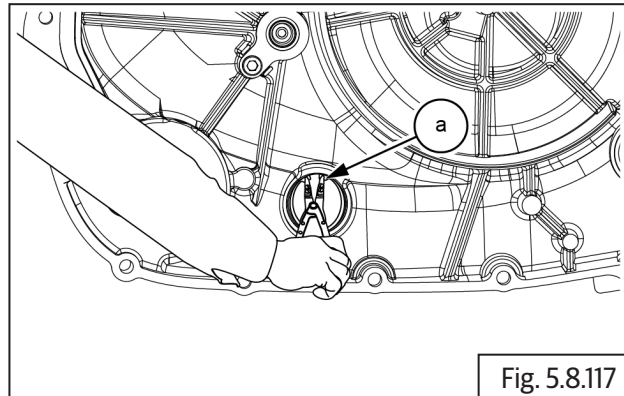

Fig. 5.8.117



Circlip plier

5.3.31. Oil Bypass seal

- Locate oil seal **(a)** in cover LH and fix it firmly using a rubber mallet.

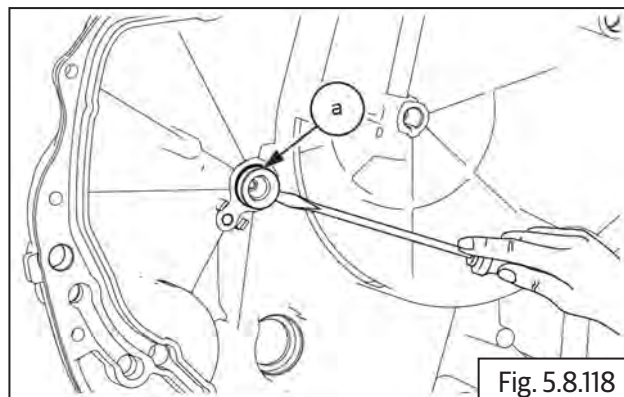

Fig. 5.8.118



Rubber Mallet

- Locate retainer plate **(b)** along with 2 Nos M6 bolts **(a)**.

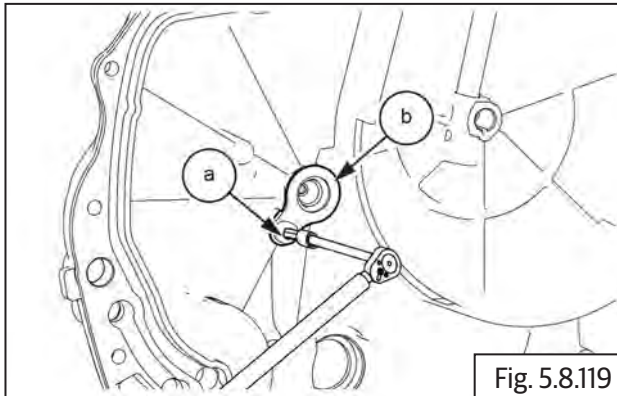

Fig. 5.8.119



5 mm Allen socket with Ratchet

5.3.32. Clutch Actuating Lever Assembly

- Assemble clutch actuating lever **(a)** and spring onto clutch shaft **(b)** on RH cover.
- Rotate shaft fully and assemble actuating lever.
- Locate and tighten Hex head bolt **(M6)** **(a)** in clutch actuating lever assembly **(b)**.

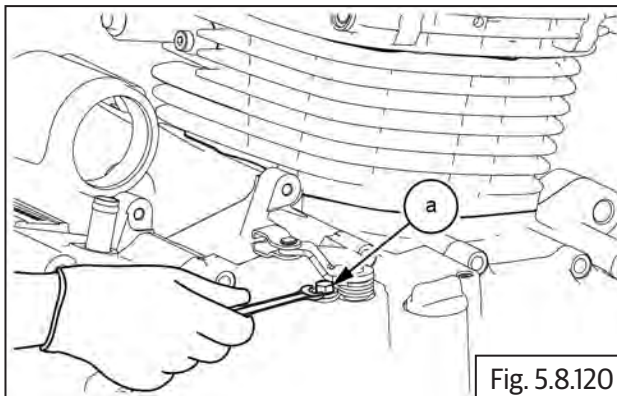

Fig. 5.8.120



10 mm Socket with Torque Wrench

Torque 10-12 N-m/01.0-1.2 kgf-m

5.3.33. Cover crankshaft center

- Install Cover crankshaft center **(a)** along with new O-ring **(a)** using 2 nos. allen bolts in LH cover.

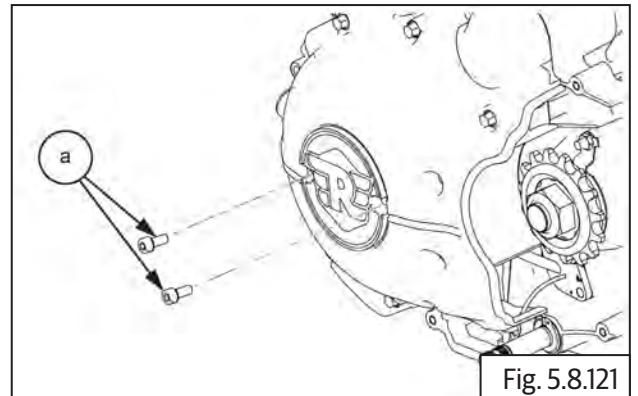

Fig. 5.8.121



14 mm Allen Socket with Ratchet

Torque 18-22 N-m/1.8-2.2 kgf-m

5.3.34. Cover RH

- Install 2 nos dowel pins **(a)** on RH crankcase

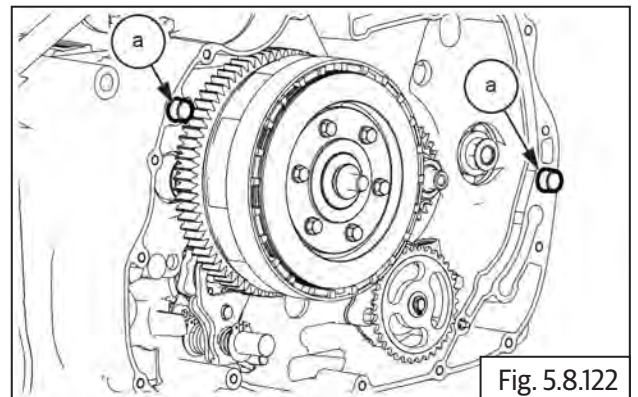
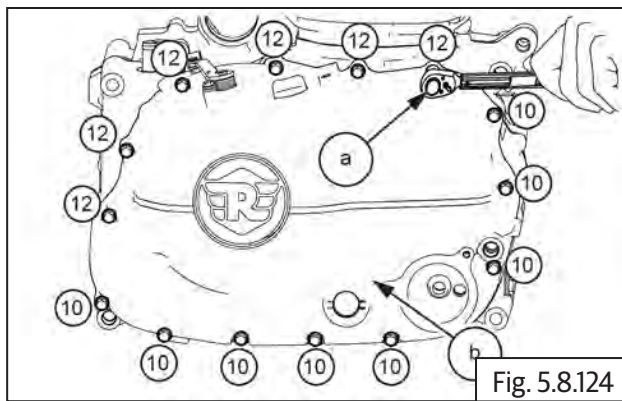
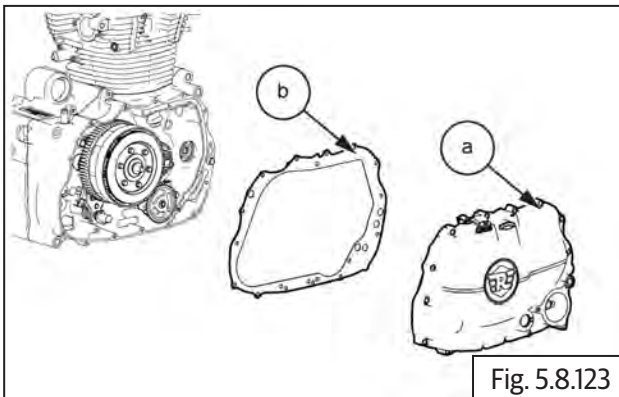

Fig. 5.8.122

- Install the clutch cover **(b)** on the crankcase along with gasket **(a)** and tighten the 18 Nos. bolts **(M6)** in the given sequence.



NOTE

- Soak Oil Filter in engine oil before installation
- Install oil filter **(a)** on the cover RH. The spring in the oil filter should be facing outside.

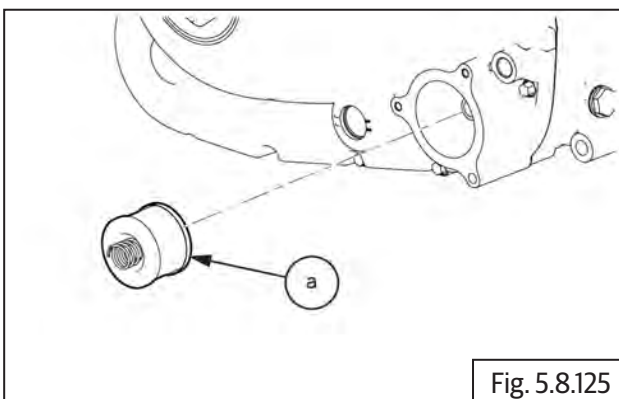

- Install O-Ring **(a)** on the oil filter cover **(b)**.

NOTE

- Oil filter O-Ring is one time use only. **DO NOT** reuse.

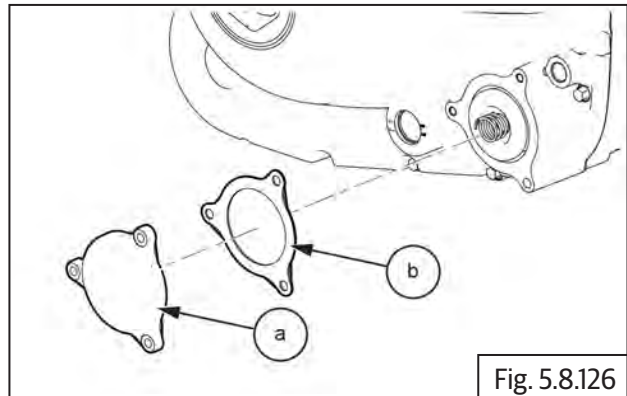

- Install oil filter cover **(a)** on the RH cover and tighten 3 Nos **(M6)** bolts.

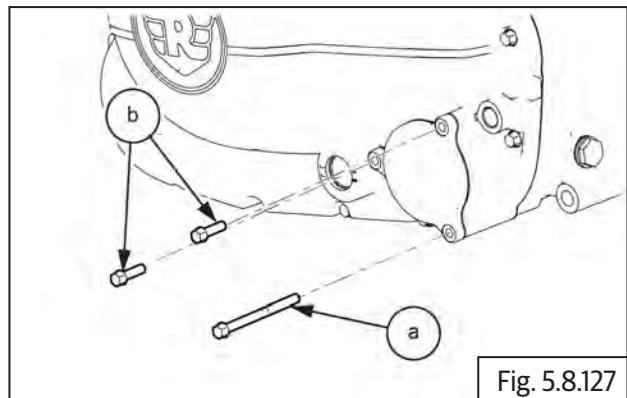

8 mm Socket with Torque Wrench

Torque

10-12 N-m/01.0-1.2 kgf-m

5.3.35. Starter Idler Gear

NOTE
<ul style="list-style-type: none"> Lubricate idler gear shafts with engine oil before installation.

- Install two starter idler gears **(a)** and **(b)** with shafts on LH crankcase.

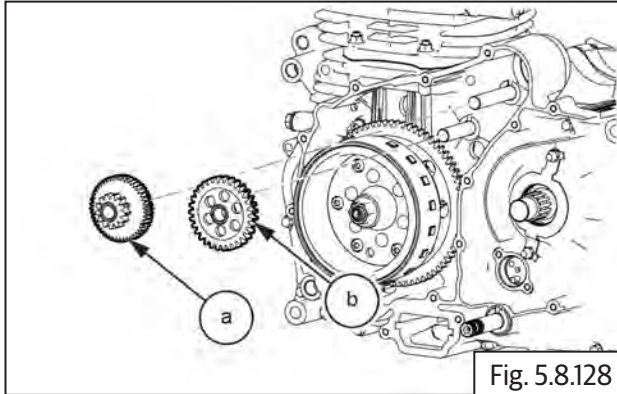

- Install collar **(a)** on each shaft.

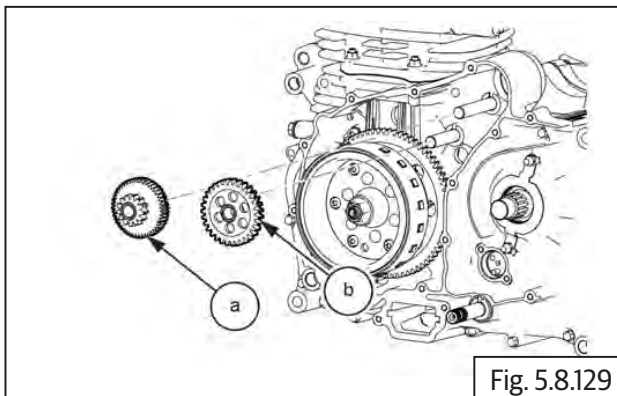

5.3.36. Cover LH

- Install dowel pin **(a)** into the grooves provided in the crankcase LH.

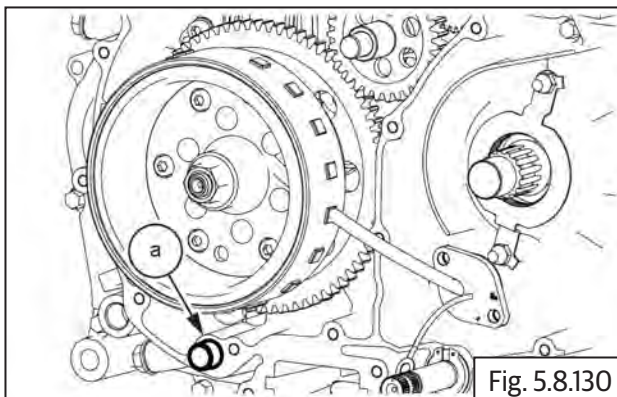

- Apply sealant in gromet.

NOTE
<ul style="list-style-type: none"> Apply Loctite Superflex 24 around the gromet before installation.

- Install new gasket **(a)** into cover LH.

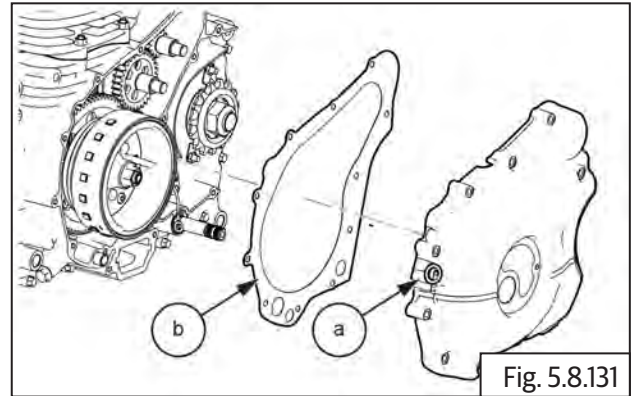

- Install magneto using 14 Nos. bolts **(a) (M6)** in sequence mentioned below.

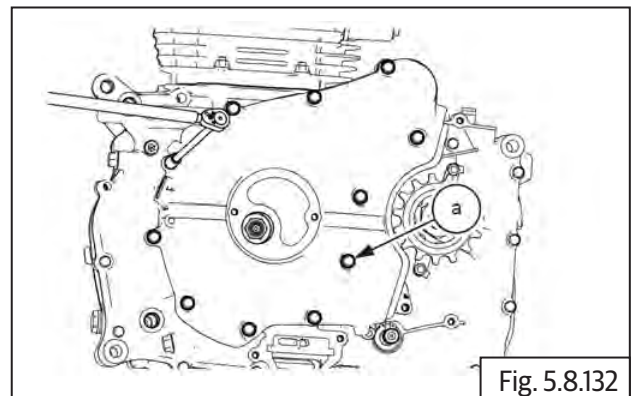

	8 mm Socket with Ratchet
Torque	10-12 N-m/1.0-1.2 kgf-m

5.3.37. Gear Position Sensor

NOTE

- Apply *BONDERITE S-0240* around the O-Ring before installation.

- Install new O-ring **(a)** over Gear Position Sensor **(b)** on the crankcase using 2 Nos. bolts **(c) (M6)** (for **EURO IV Model**).

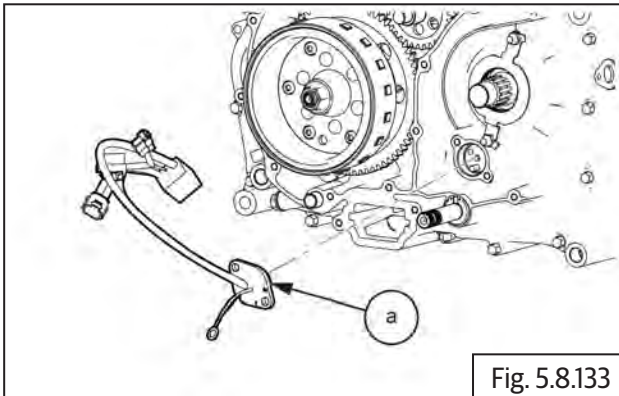

Fig. 5.8.133

- Install new O-ring **(a)** over Gear Position Sensor **(b)** on the crankcase using 2 Nos. bolts **(c) (M6)** (for **EURO V Model**).

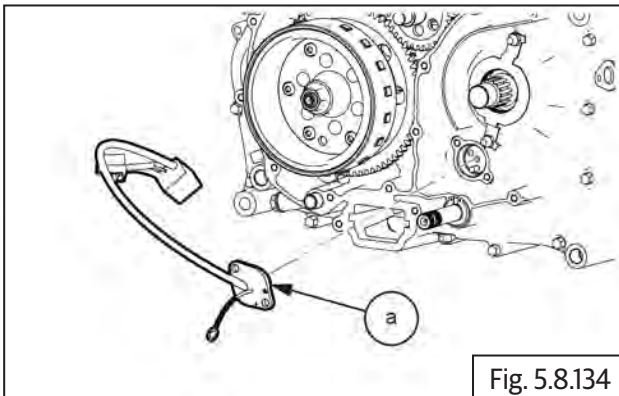

Fig. 5.8.134

- Install retainer-Gear Position Sensor Wire **(a)** using 2 nos bolts.

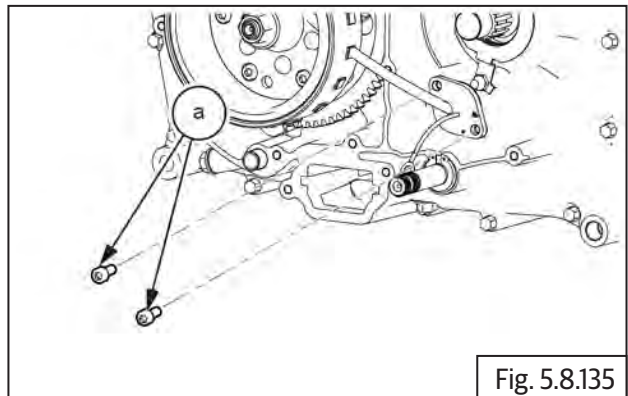

Fig. 5.8.135



8 mm Socket with Ratchet

Torque

10-12 N-m/1.0-1.2 kgf-m

NOTE

- Ensure *ACG wire and GPS wire packaged inside the clamp of gear position sensor*

5.3.38. Starter motor

NOTE

- Inspect O-Ring for damages. Replace if required.
- Apply oil around the O-Ring before installation.

- Install the starter motor **(a)** using 2 Nos. allen bolts **(M6)**.

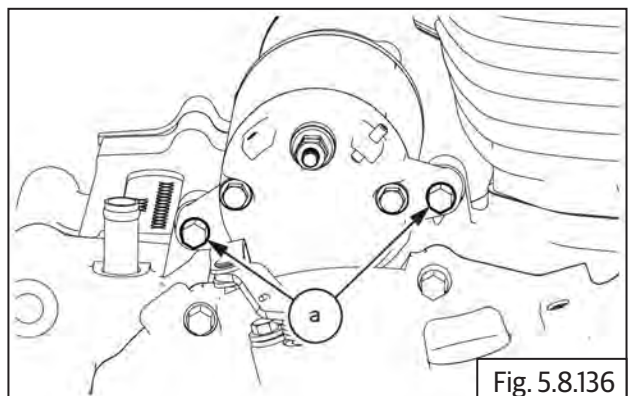

Fig. 5.8.136



5 mm Socket with Ratchet

Torque

10-12 N-m/1.0-1.2 kgf-m

5.3.39. Oil Strainer

- Apply fresh engine oil and insert oil strainer (a) gently till you hear a click sound.

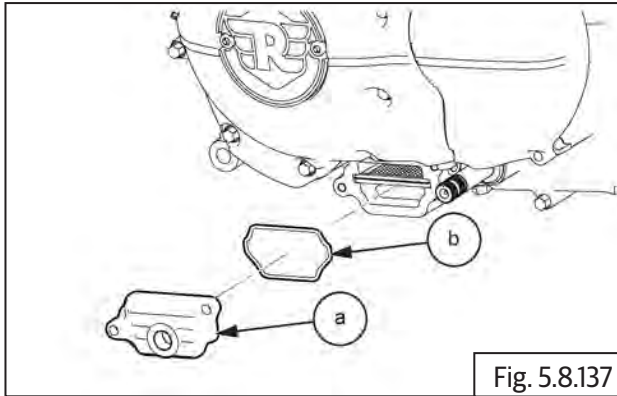

- Place new O-Ring (a) on the strainer cover (b).

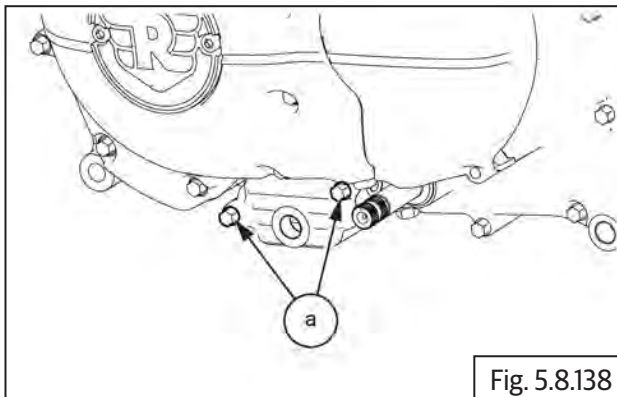

- Refill engine oil with recommended quantity.
- Assemble engine oil filler cap.

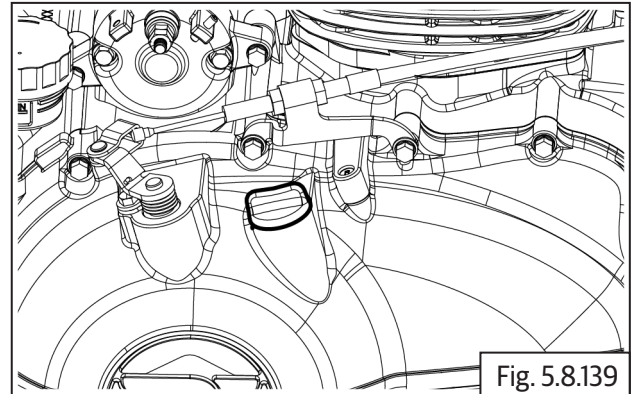

- Start and warm up engine for 2 to 3 minutes and then turn it "OFF".
- Check oil level through oil level window.

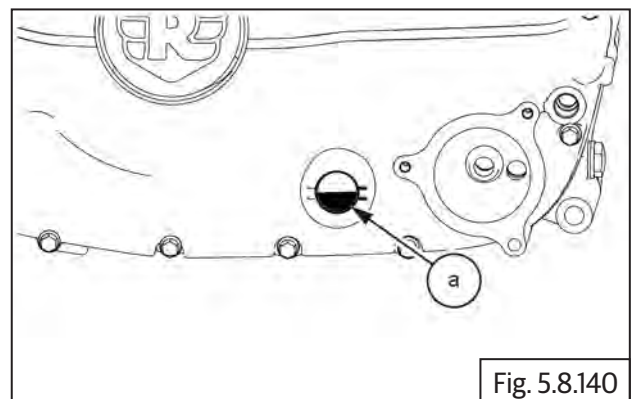

NOTE

- Strainer cap O-Ring is one time use only. DO NOT reuse.
- Apply engine oil on o-ring before assembly

Dry Fill	2.5 Liters / 0.55 Imperial gallon
Grade	SAE 15W50 APISL, JASO MA2, SEMI SYNTHETIC

	8 mm Socket with Ratchet
Torque	8-12 N-m/0.8-1.2 kgf-m

5.3.40. Breather Hose

- Install breather hose (b) using a clamp (a).

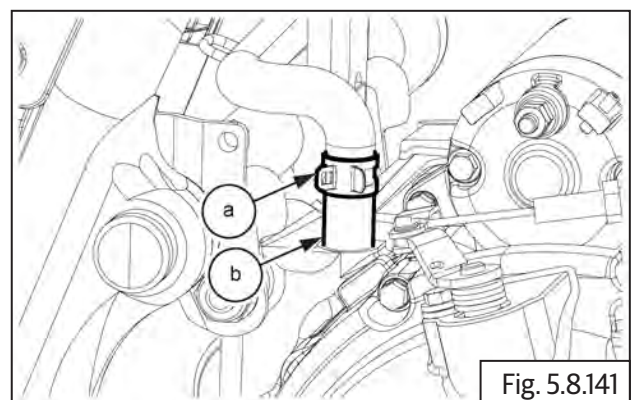

	Nose Plier
--	------------

5.3.41. FD sprocket

- Install the tab washer (a) and "U" nut (c) (M20).

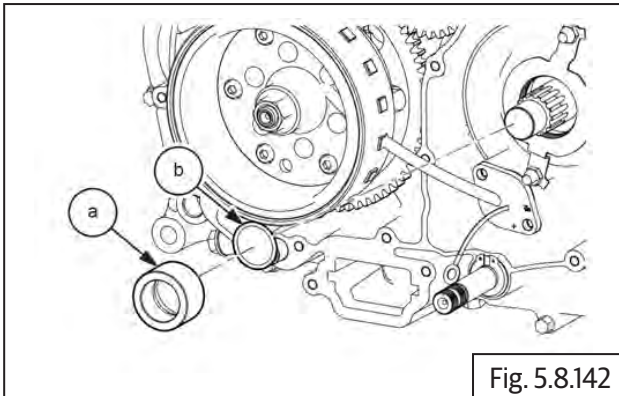

Fig. 5.8.142

- Install the FD sprocket (a).

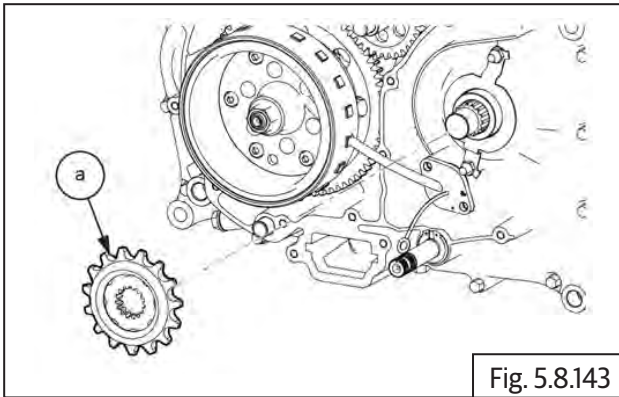

Fig. 5.8.143

- Lock the FD sprocket (a) from rotating using special tool (b).

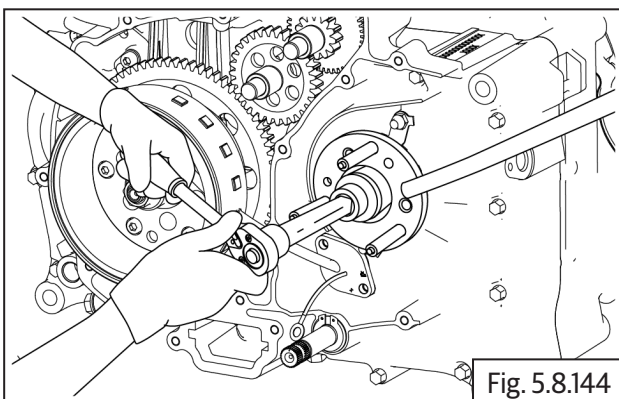

Fig. 5.8.144

	SPL
	Part No: ST-27534-2
Part Name: FD sprocket holder	

	30 mm Socket with Ratchet
Torque	130-160 N-m/13.0-16.0 kgf-m

- Lock using tab washer holder (a).

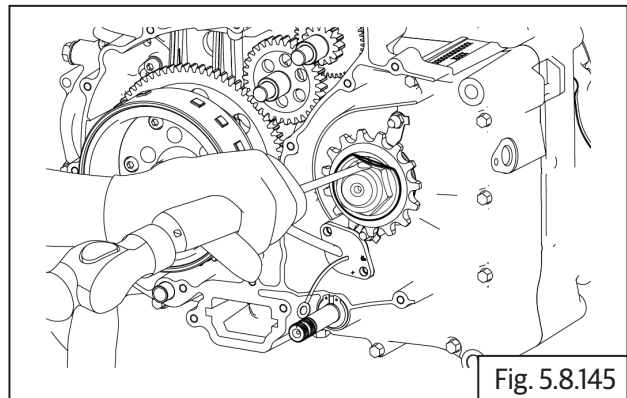

Fig. 5.8.145

	Chisel and Hammer
--	-------------------

5.3.42. Throttle Body

- Install throttle body (b) in inlet manifold using 2 Nos. allen bolts (M5) (a) (for EURO IV Model).

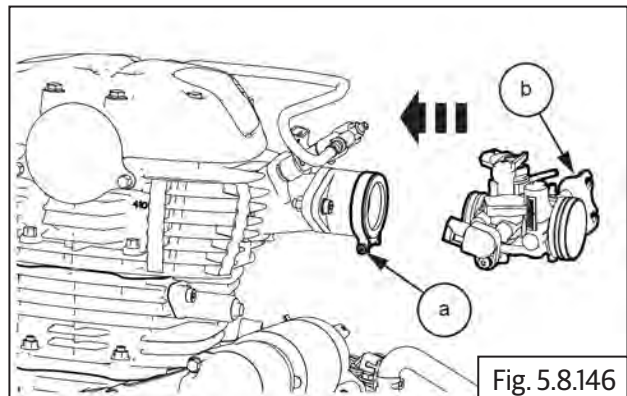

Fig. 5.8.146

- Install throttle body (b) in inlet manifold using 2 Nos. allen bolts (M5) (a) (for EURO V Model).

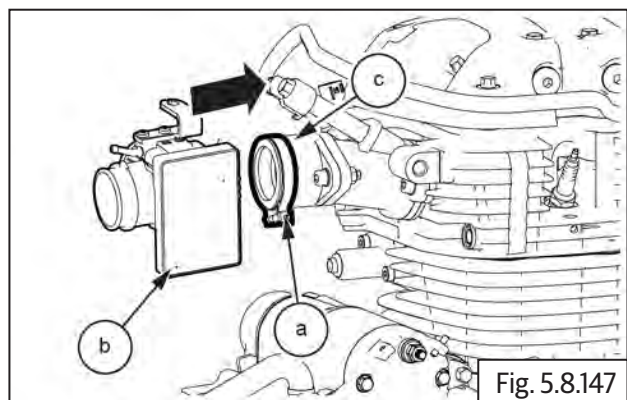
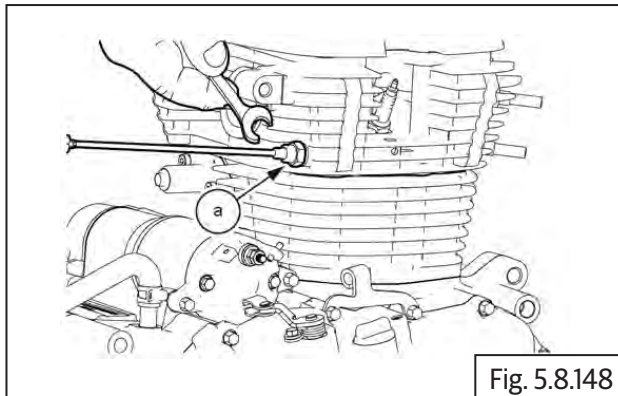



Fig. 5.8.147

	4 mm Allen Socket with Ratchet
Torque	3-7 N-m/0.3-0.7 kgf-m

5.3.43. Engine Oil Temperature/EOT sensor

- Install the EOT sensor **(a)** along with the O-ring using circlip and special tool.



	17 mm Open end spanner
Torque	15-20 N-m/1.5-2.0 kgf-m

5.3.44. Oil Cooler

- Align the oil cooler inlet & outlet pipes **(a)** on RH and LH crankcase.

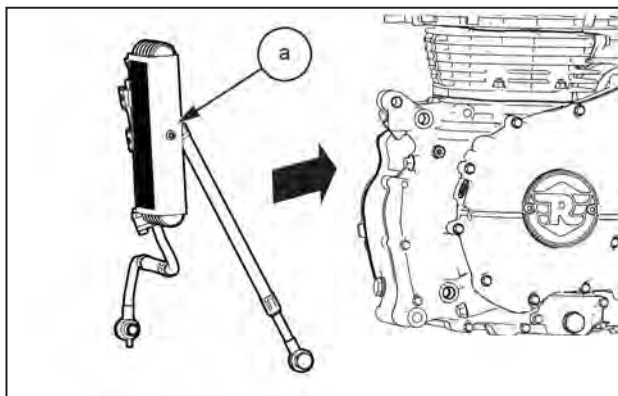

- Install the 1 No. banjo bolt **(a)** on LH and RH crankcase.

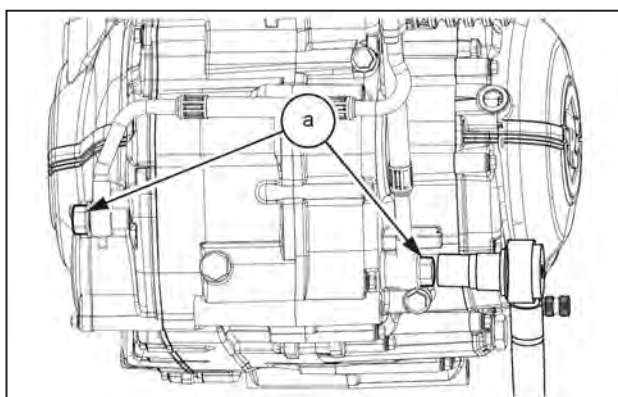

ENGINE ASSEMBLY TO FRAME

Engine Assembly to Frame

CONTENTS	PAGE
5.4 Engine Assembly to Frame.....	129
5.4.2. Engine Mounting Final Torque.....	130
5.4.3. Cradle Frame Mountings.....	130
5.4.4. Gear Position Indicator Sensor	131
5.4.5. FD Sprocket	132
5.4.6. FD Sprocket Cover	133
5.4.7. Gear Shift Linkage	133
5.4.8. Breather Hose Connection	134
5.4.9. Spark Plug Suppressor Caps	134
5.4.10. Starter Motor Connections	134
5.4.11. Magneto/Side Stand Switch Connectors	134
5.4.12. Exhaust Pipe on Cylinder Head.....	135
5.4.13. Hego/Oxygen Sensor Connectors	136
5.4.14. Throttle Body.....	136
5.4.15. Air Filter Housing to Throttle Body.....	136
5.4.16. Injector Connections	137
5.4.17. Throttle Cable.....	137
5.4.18. Fuel Tank.....	137
5.4.19. Drain Hose	137
5.4.20. EVAP Connections to Fuel Tank	138
5.4.21. Fuel Hose (Fuel Pump to Injector).....	138
5.4.22. Fuel Pump Connector	138
5.4.23. Battery Connections.....	140
5.4.24. Rider Seat Assembly on Frame	140
5.4.25. Pillion Backrest and Seat Assembly on Frame	141

Engine Assembly to Frame

CONTENTS

PAGE

5.4.26. Side Panel LH.....	141
5.4.27. Side Panel RH	141
5.4.28. Drain Bolt and Engine Oil Re-fill.....	142

5.4 Engine Assembly to Frame

5.4.1. Engine to main frame

⚠ WARNING

DO NOT tighten bolts during initial installation.

- Support engine suitably and firmly on a flat jack and ensure it is stable.
- Locate jack **(a)** along with engine **(b)** below the frame.

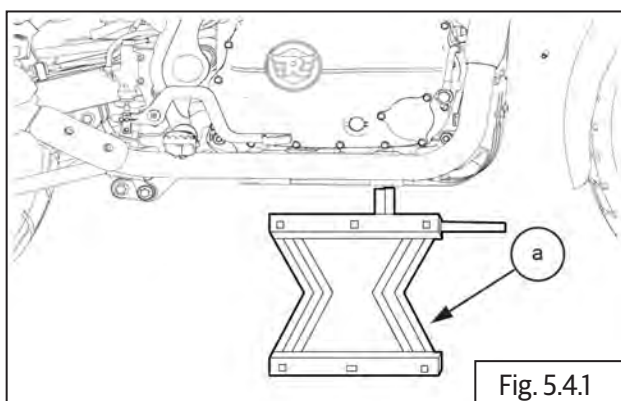

- Lift the jack slowly and align mounting holes of frame with mounting hole on engine.
- Insert Hex flange bolt long **(M10) (a)** into mounting holes on the main frame rear top, insert washer **(b)** and nut **(c)** on other side.

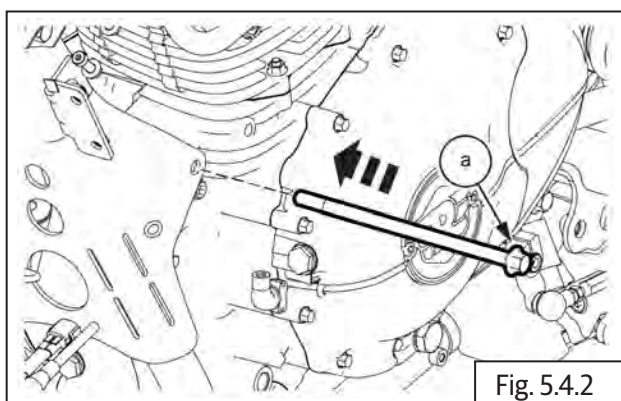

- Insert Hex head bolt **(M10) (a)** into mounting holes on rear frame bottom.
- Assemble washer **(b)** and nut **(c)** on bolt. **DO NOT TIGHTEN FULLY.**

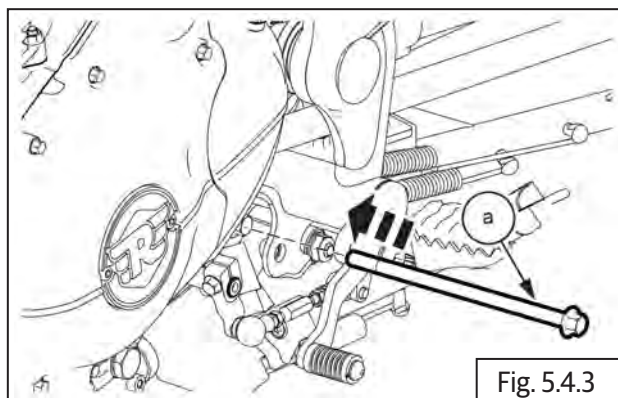

14 mm Ring spanner and 14 mm Hex socket with Ratchet

- Insert Hex head bolt **(M10) (a)** into mounting holes on rear frame **(b)** top.
- Assemble washer and nut **(c)** on bolt. **DO NOT TIGHTEN FULLY.**

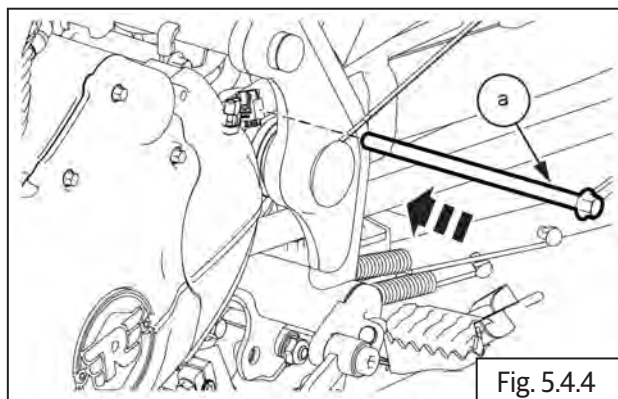

14 mm Ring spanner and 14 mm Hex socket with Ratchet

5.4.2. Engine Mounting Final Torque

- Hold Hex nut **(M10)** and tighten the bolt to specified torque.

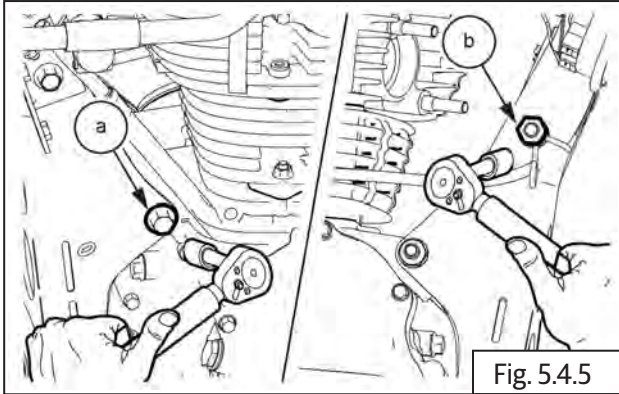

Fig. 5.4.5

	14 mm Ring spanner and 14 mm Hex socket with Torque wrench
Torque	45-55 N-m/4.5-5.5 kgf-m

- Tighten Hex head bolt **(M10)** **(a)** into mounting holes on frame rear bottom to torque.

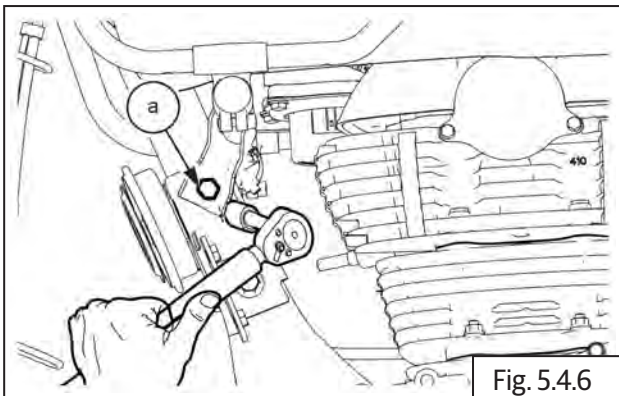

Fig. 5.4.6

	14 mm Ring spanner and 14 mm Hex socket with Torque wrench
Torque	45-55 N-m/4.5-5.5 kgf-m

- Tighten Hex socket bolts **(M10)** **(a)** with nut **(b)** on top rear frame **(c)** to engine.

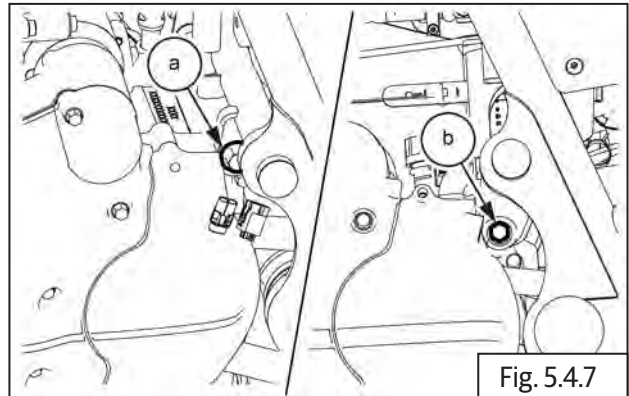

Fig. 5.4.7

	14 mm Ring spanner and 14 mm Hex socket with Torque wrench
Torque	45-55 N-m/4.5-5.5 kgf-m

5.4.3. Cradle Frame Mountings

- Align cradle frame **(a)** to engine **(b)** and main frame.

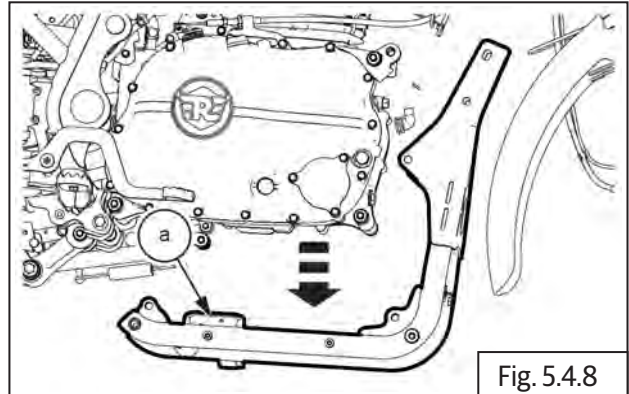
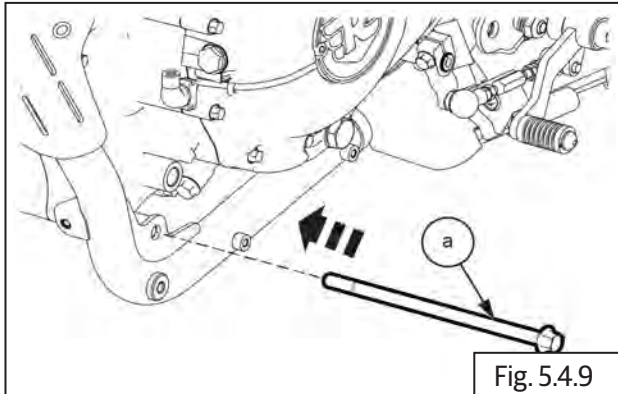



Fig. 5.4.8

- Locate 1 No long bolt along with nut **(a)** on cradle frame bottom to engine. **DO NOT TIGHTEN FULLY.**



	14 mm Ring spanner and 14 mm Hex socket with Torque wrench
Torque	45-55 N-m/4.5-5.5 kgf-m

- Locate 1 No hex head bolt **(a)** on cradle frame RH bottom to frame **(b)**. **DO NOT TIGHTEN FULLY.**

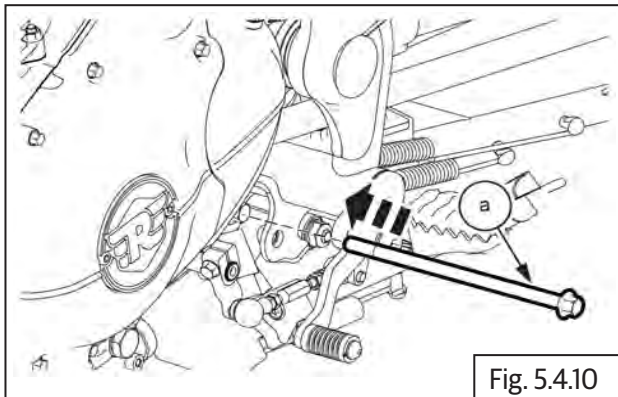

	12 mm Hex socket with Torque wrench
Torque	22-28 N-m/2.2-2.8 kgf-m

- Locate 1 No hex head bolt **(a)** along with nut on cradle frame LH bottom to frame. **DO NOT TIGHTEN FULLY.**

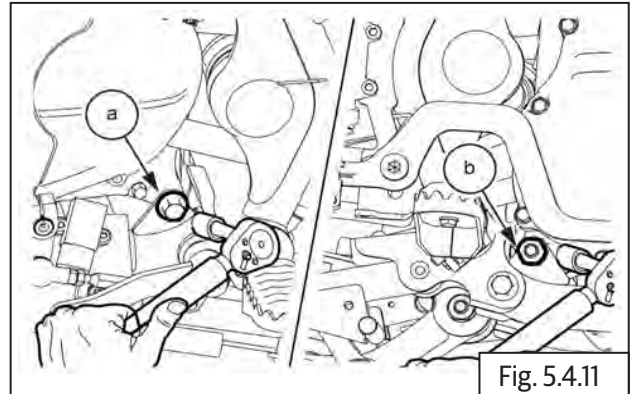

	14 mm Ring spanner and 14 mm Hex socket with Torque wrench
Torque	45-55 N-m/4.5-5.5 kgf-m

5.4.4. Gear Position Indicator Sensor

- Connect gear position sensor **(a)** to connector located behind engine.

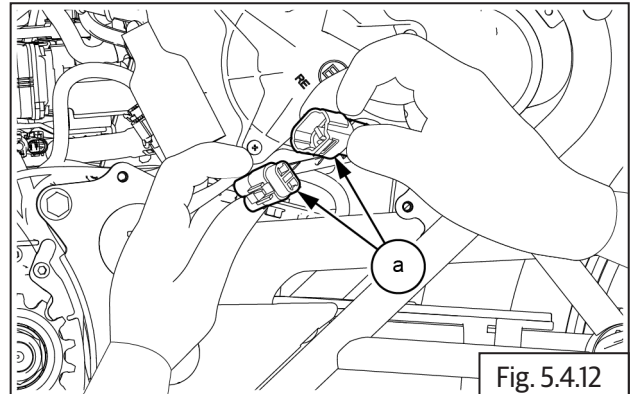

5.4.5. FD Sprocket

⚠ CAUTION

Ensure gear is in **NEUTRAL** position before assembling.

- Locate FD sprocket **(a)** to drive shaft.

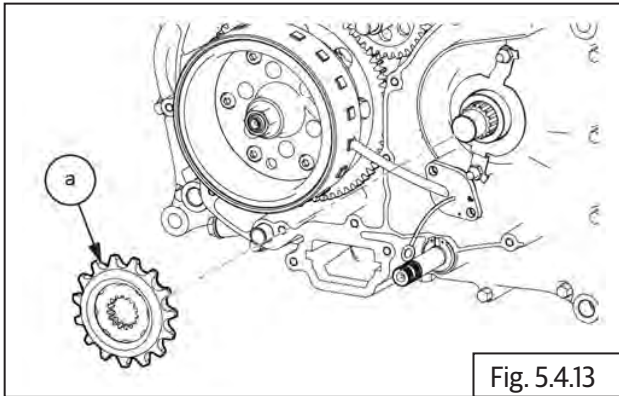

- Loosen rear wheel mountings and chain adjusters and push rear wheel into swing arm to increase chain slack.
- Position rear chain over FD sprocket teeth properly.
- Assemble chain **(a)** on FD sprocket **(b)**.

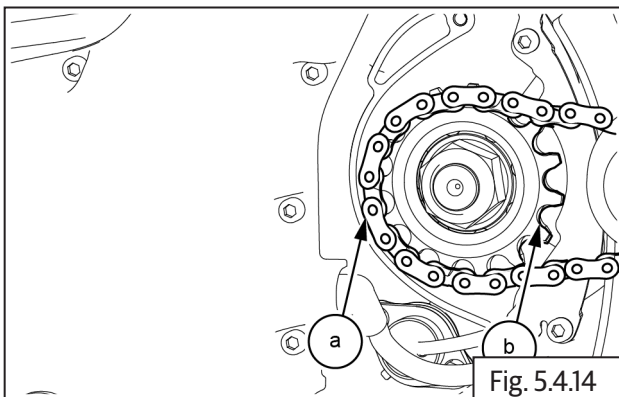

- Apply rear brake **(a)**.

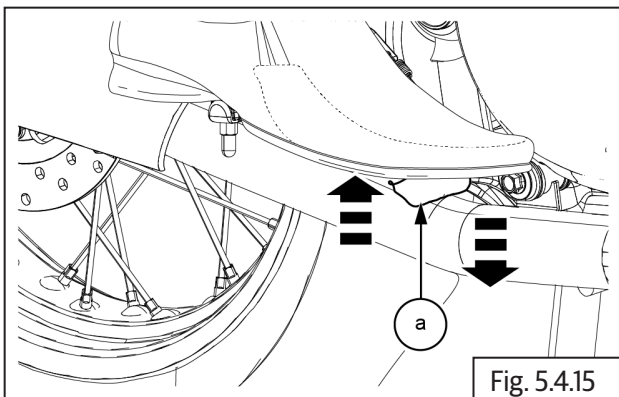

- Locate FD sprocket U nut **(a)** along with tab washer and tighten it.

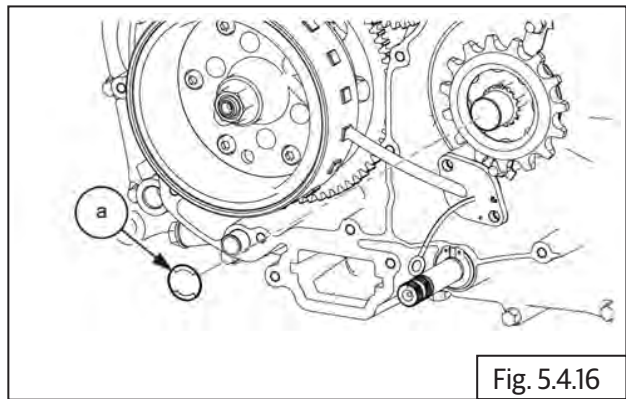

	30 mm socket and Torque wrench
Torque	130-160 N-m/13.0-16.0 kgf-m

- Adjust rear chain tension to specification: 30 mm to 40 mm ([section 6.8.9](#)).

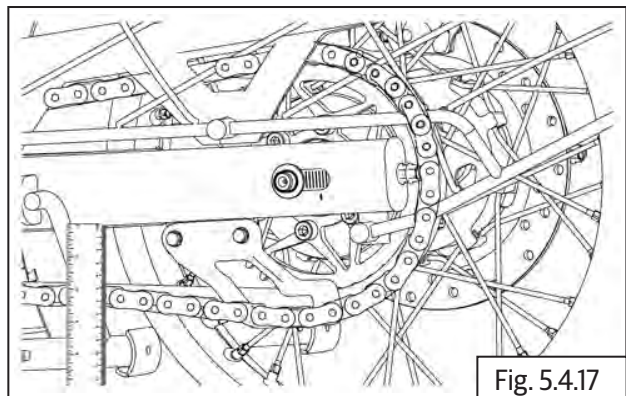

- Tighten rear wheel axle nut **(a)** ([section 6.8.8](#)).

5.4.6. FD Sprocket Cover

- Assemble FD sprocket cover **(a)** on crankcase LH.
- Locate 2 Nos. Hex socket head bolts **(M6) (b)** on FD sprocket cover and tighten in a crisscross pattern to specified torque.

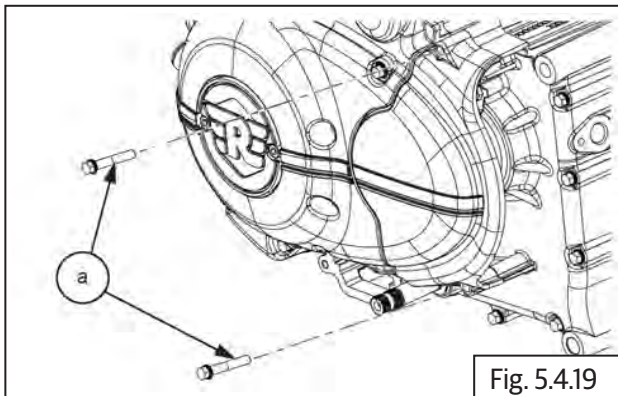
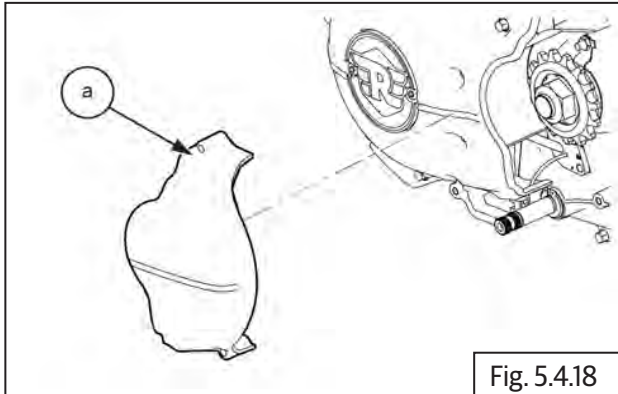

	5 mm Allen socket and Torque wrench
Torque	8-12 N-m/0.8-1.2 kgf-m

5.4.7. Gear Shift Linkage

- Align dot mark in shaft serration with the slot in gear pedal linkage
- Locate Hex bolt **(M6) (a)** to install gear pedal linkage

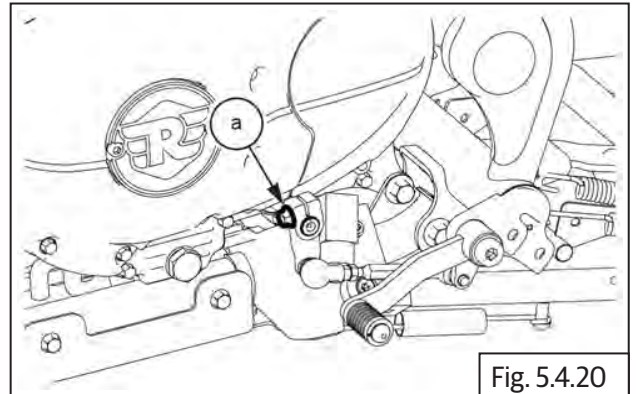

	10 mm Socket with Ratchet
Torque	8-12 N-m/0.8-1.2 kgf-m

- Locate Hex bolt **(M10) (a)** on gear lever and tighten to specified torque.

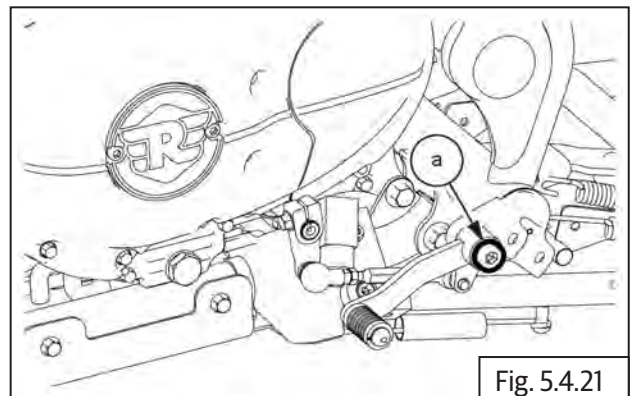

	14 mm socket with Torque wrench and 17 mm Ring SPanner
Torque	21-29 N-m/2.1-2.9 kgf-m

5.4.8. Breather Hose Connection

- Insert breather hose **(b)** on the tube into crankcase plug **(c)**. Position the clip **(a)** on hose correctly.

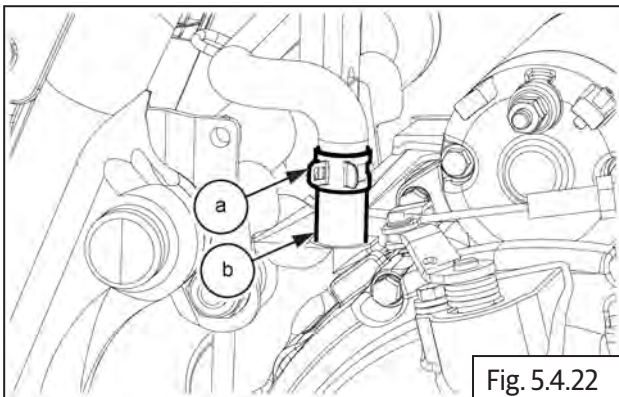

	Nose plier
---	------------

5.4.9. Spark Plug Suppressor Caps

- Gently insert spark plug suppressor **(a)** into spark plug **(b)**.

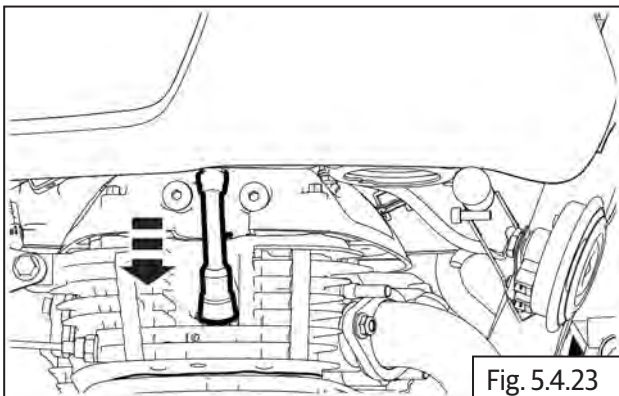

5.4.10. Starter Motor Connections

- Connect starter motor negative (-) cable **(a)** to terminal.
- Assemble 2 Nos. Hex flange head bolts **(M6) (b)** into starter motor tighten firmly.

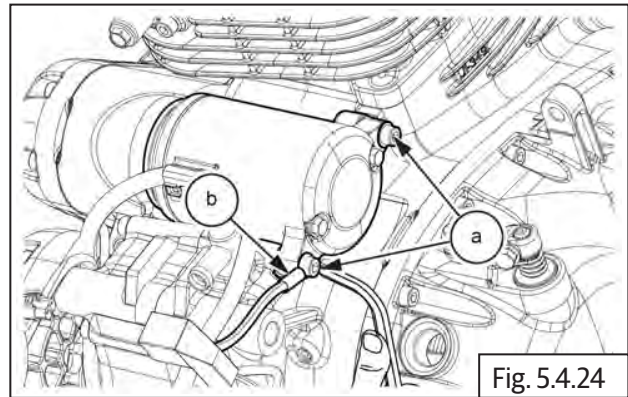

	10 mm Socket with Ratchet
Torque	8-12 N-m/0.8-1.2 kgf-m

- Connect positive (+) cable **(a)** to starter motor terminal. Assemble Hex nut **(M6) (b)** and tighten firmly, duly ensuring the cable/terminal does not rotate.
- Slide protective cap over terminal on starter motor.

5.4.11. Magneto/Side Stand Switch Connectors

- Connect magneto sensor connector located on rear of the engine.

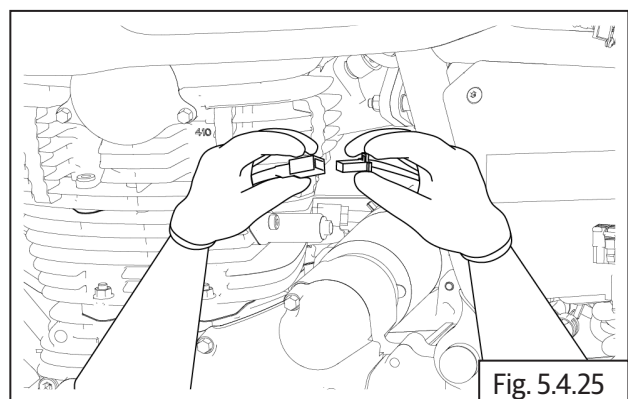

- Connect side stand switch connector **(a)** located on rear top of engine.

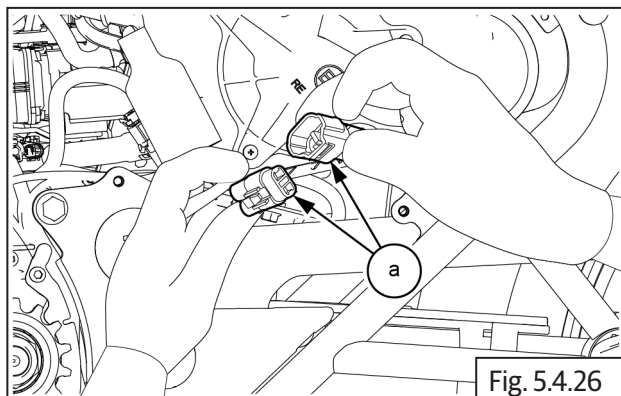

Fig. 5.4.26

5.4.12. Exhaust Pipe on Cylinder Head

- Locate exhaust pipe **(a)** into exhaust manifold on the cylinder head and ensure the exhaust pipe flange is properly located on the studs.

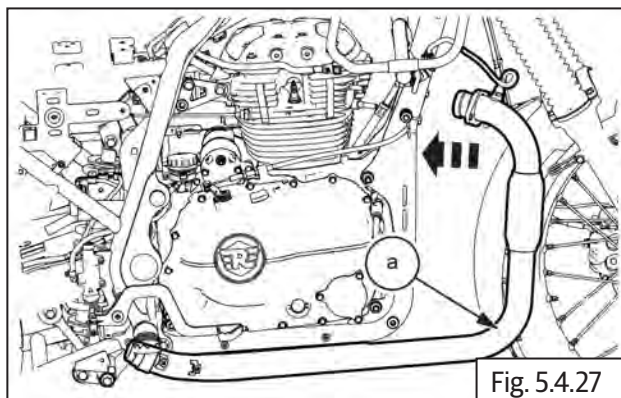

Fig. 5.4.27

- Assemble 2 nos hex nuts **(a)** on the studs and hand tight it to align the rear end mounting.

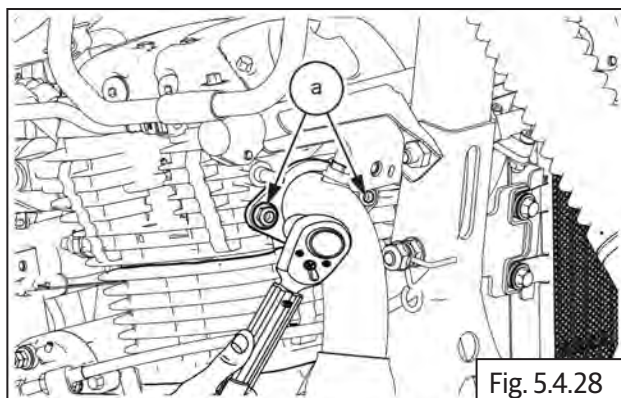



Fig. 5.4.28

	14 mm socket with ratchet
---	---------------------------

- Tighten the clamp bolt **(a)** at exhaust header pipe outer end.

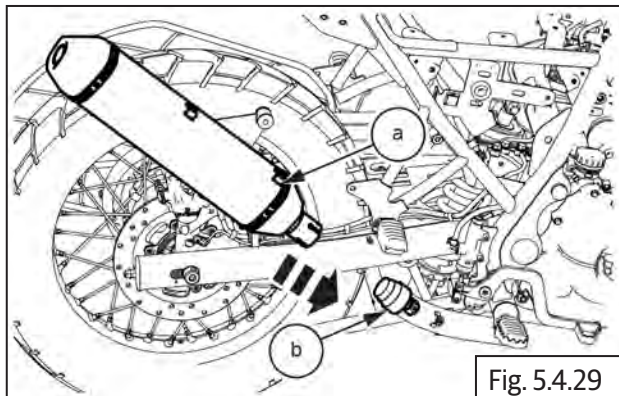



Fig. 5.4.29

	12mm socket with ratchet
Torque	28-35 N-m/2.8-3.5 kgf-m

8.4.1. Silencer

- Insert the silencer in the catalytic converter outer pipe.

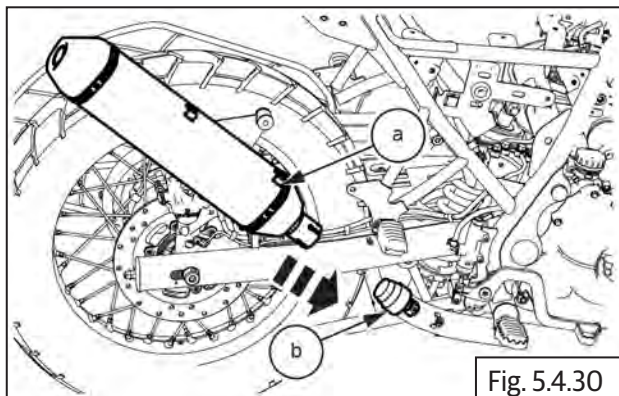

Fig. 5.4.30

- Locate the mounting hole in the frame and insert **(M8)** bolt **(a)** and tighten it.

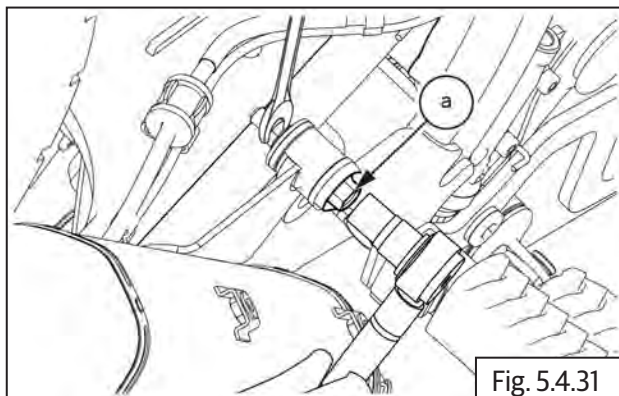

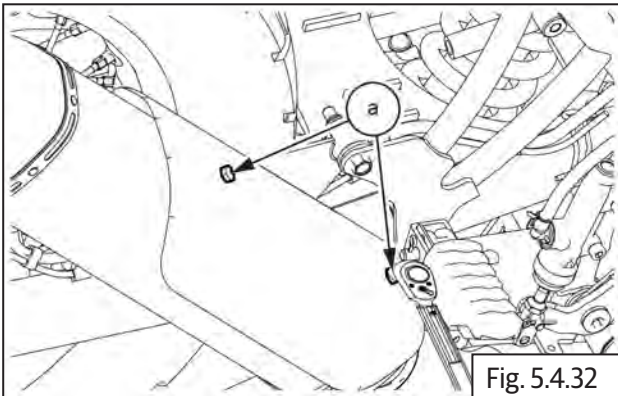



Fig. 5.4.31

	12 mm socket with ratchet
Torque	21-29 N-m/2.1-29 kgf-m

- Locate the silencer guard back plate **(a)** and fix it in the silencer with 3 Nos **(M6) (b)** hex socket bolts..



	10 mm socket with ratchet
Torque	10-12 N-m/1.0-1.2 kgf-m

5.4.13. Hego/Oxygen Sensor Connectors

- Ensure Hego/oxygen sensor are tightened fully on exhaust pipe.
- Connect Hego/Oxygen sensor connector **(a)** in frame **(b)**.
- Ensure connectors are locked properly. (There is a "Click" sound when locked).

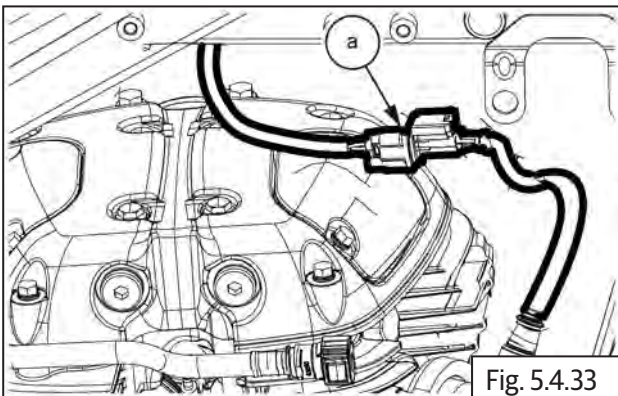

5.4.14. Throttle Body

- Insert throttle body **(b)** into intake manifold flange **(a)**

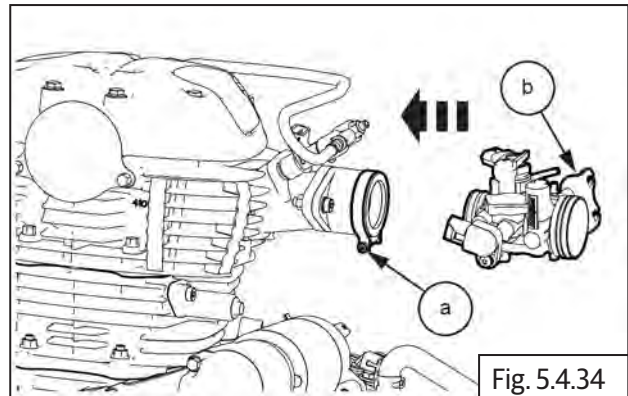

- Connect wiring harness coupler to ECU.

5.4.15. Air Filter Housing to Throttle Body

- Insert throttle body rear end in the air box opening.

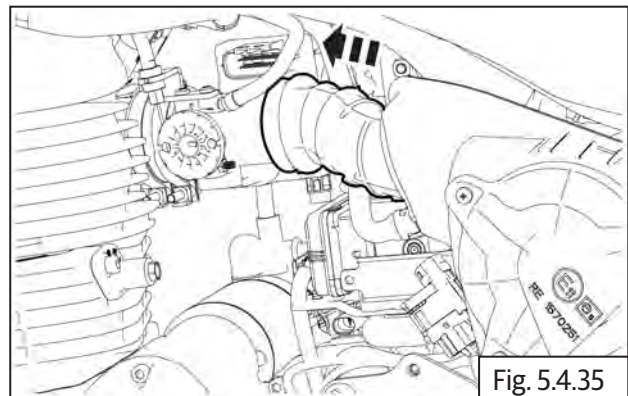

- Tighten the lock clip **(a)**.

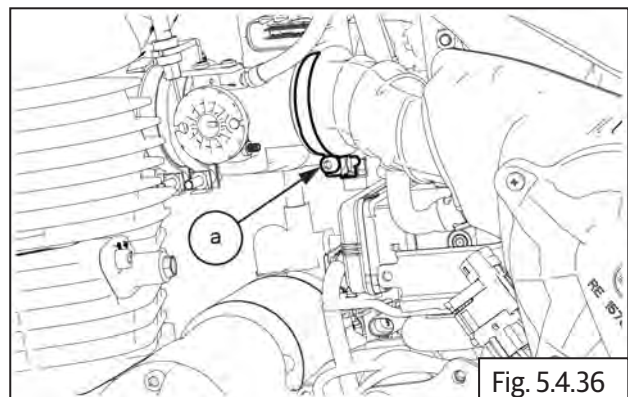

5.4.16. Injector Connections

- Connect injector connector **(a)** located on inlet manifold **(b)**.

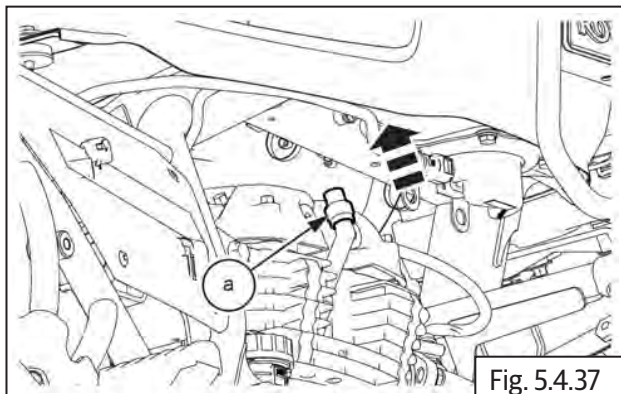

- Connect idle EVAP hoses into throttle body.

5.4.17. Throttle Cable

- Insert cable **(a)** into the slot in the bracket in the throttle body and ensure the adjuster is fully into the bracket on throttle body.

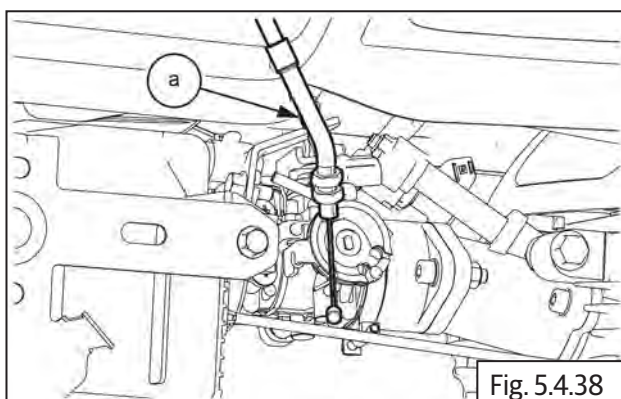

- Assemble lock nut on the inner cable.
- Ensure inner cables is seated properly in the eyelets at throttle body end and handlebar end. Gently rotate throttle rotor at handlebar and ensure they are operating properly.

- Tighten the checknut **(a)** sufficiently.

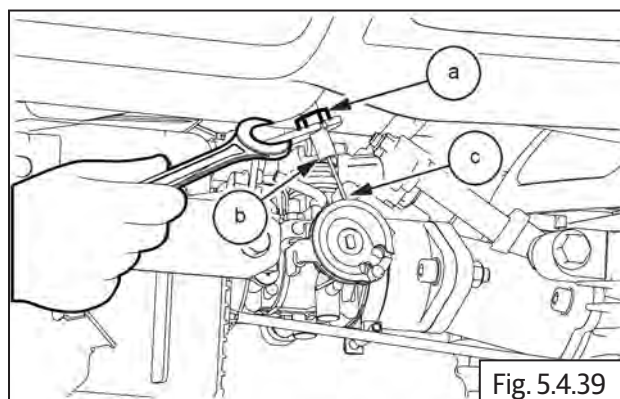

12 mm Open end spanner

5.4.18. Fuel Tank

- Hold and slide fuel tank **(a)** into frame guide **(b)** and ensure bush in fuel tank are aligned into guide in frame.

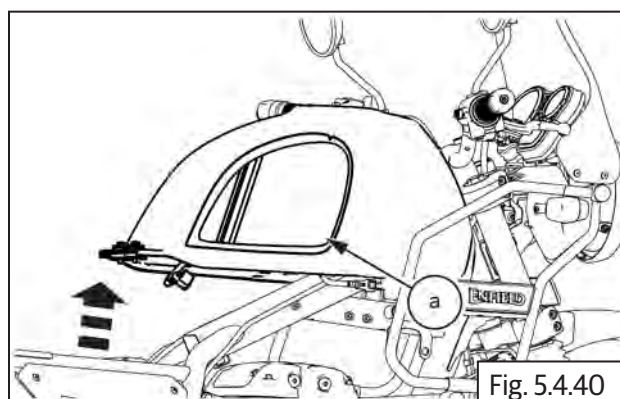

5.4.19. Drain Hose

- Gently lift fuel tank and connect drain hose connection **(a)** to fuel tank.

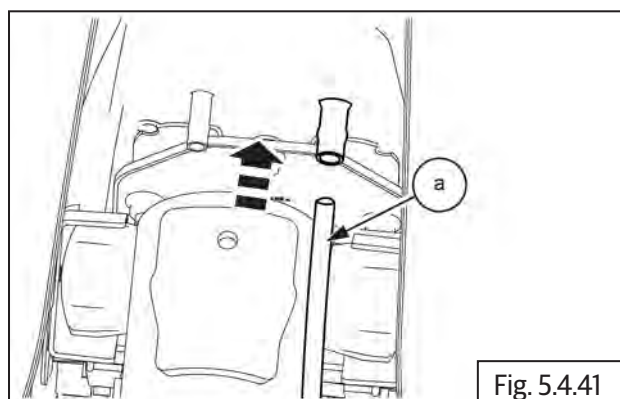

5.4.20. EVAP Connections to Fuel Tank

- Connect EVAP connection hose **(a)** to fuel tank **(b)**.

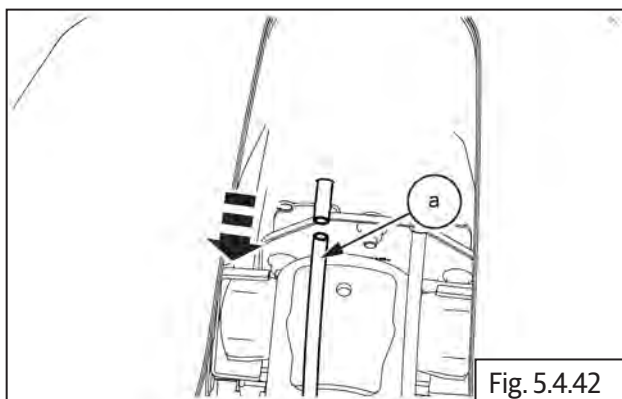

5.4.21. Fuel Hose (Fuel Pump to Injector)

- Connect fuel hose **(a)** into quick fix connector **(b)** and ensure lock button is locked with a click sound.

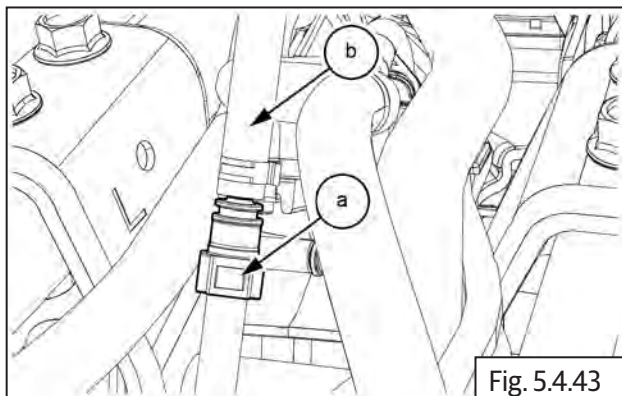

5.4.22. Fuel Pump Connector

- Connect fuel pump connector **(a)** into fuel pump **(b)**.

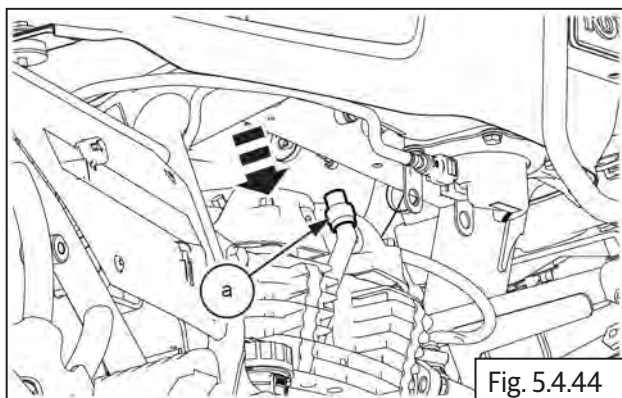

- Gently lower the fuel tank into frame.
- Locate and tighten 1 No. Hex head bolts **(M5) (a)** on rear end of fuel tank **(b)**.

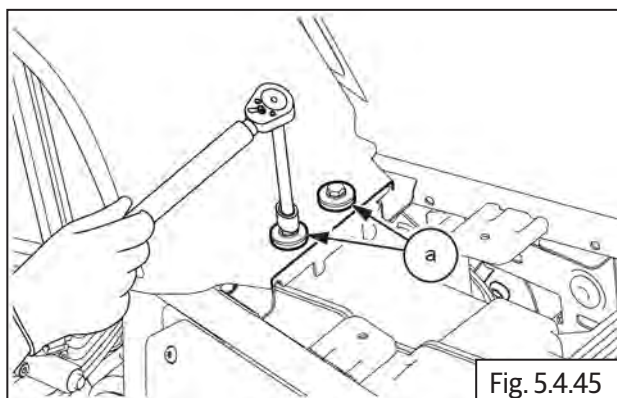

	10 mm Socket with Ratchet
Torque	10-12 N-m/1.0-1.2 kgf-m

- Insert inner cable into the cable guide **(b)** in clutch cover assembly and ensure the adjuster **(a)** is fully inside the guide in clutch cover assembly.

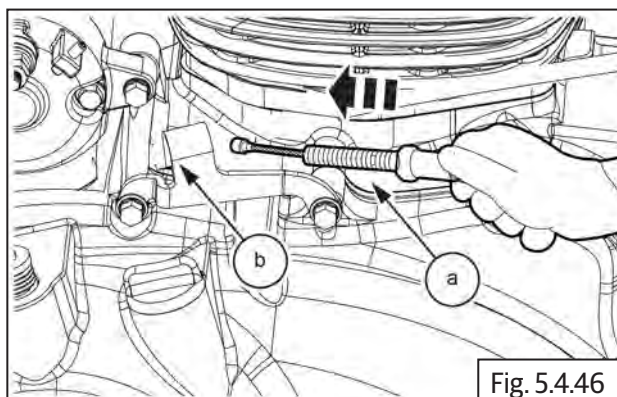

- Assemble adjuster nut **(a)** on the adjuster and tighten by a few threads.

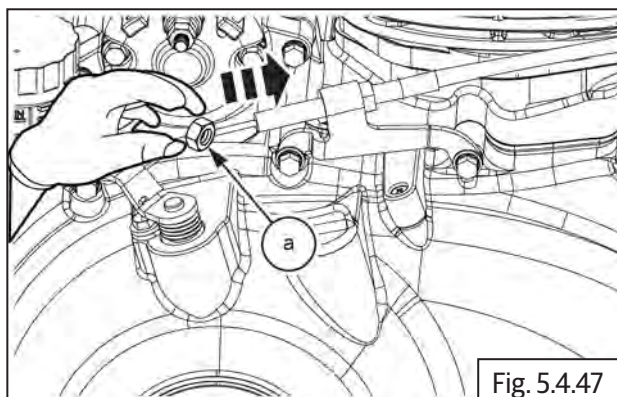

- Assemble protective rubber boot (a) on clutch cable inner (b).

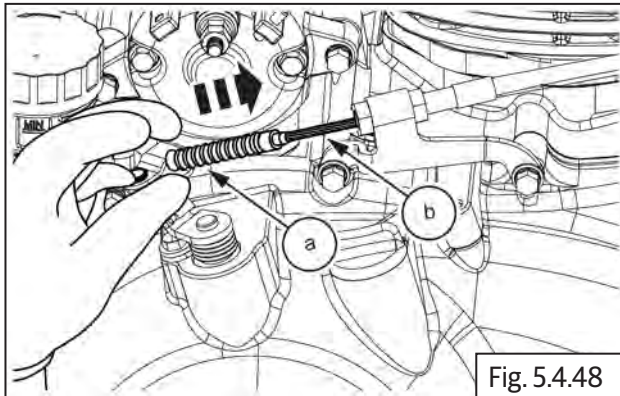

Fig. 5.4.48

- Gently locate inner cable (a) into clevis (b) in clutch actuator shaft (c).

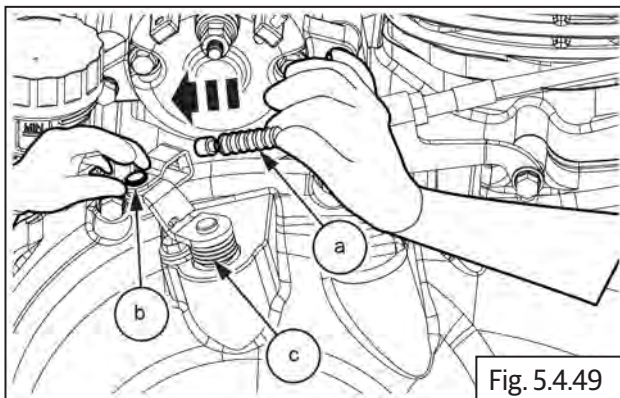

Fig. 5.4.49

Clutch Cable Free Play Adjustment

- Loosen lock nuts (a) completely in clutch cable (b).

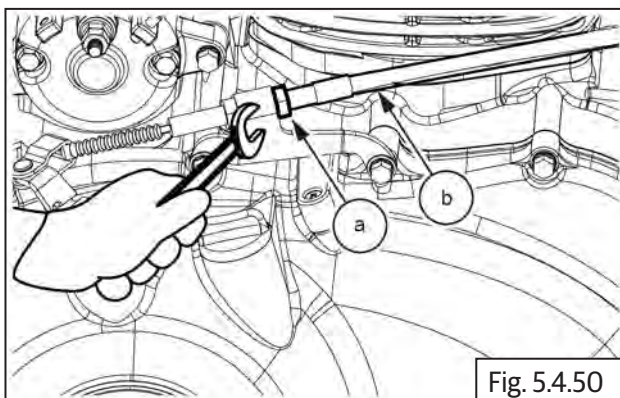



Fig. 5.4.50

	12 mm Double end spanner
---	--------------------------

- Tighten the adjuster at lever end fully.
- Adjust free play at engine to give zero free play. Tighten adjuster nuts (a) in clutch cable (b) at cover RH to recommended torque.

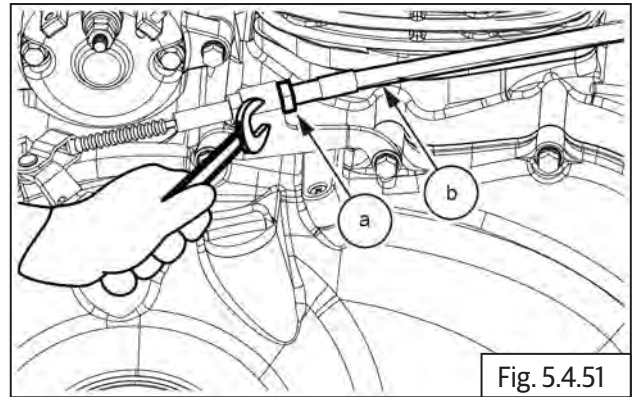



Fig. 5.4.51

	12 mm open end torque wrench
Torque	4-8 N-m/0.4-0.8 kgf-m

- Set steering to full left position, pull and release lever three times. Adjust ball end to give a free play of 10-12mm.

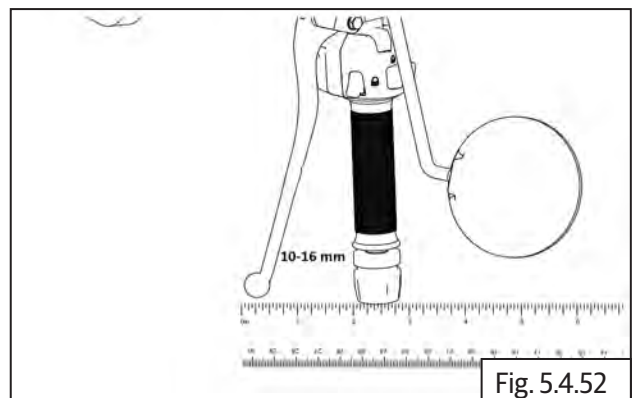

Fig. 5.4.52

- Actuate clutch lever three times and check for free play again for 10-12mm. Adjust if required.
- Check gap of 3-6mm at adjuster nut at cable end. If found to be irregular, adjust at engine end.

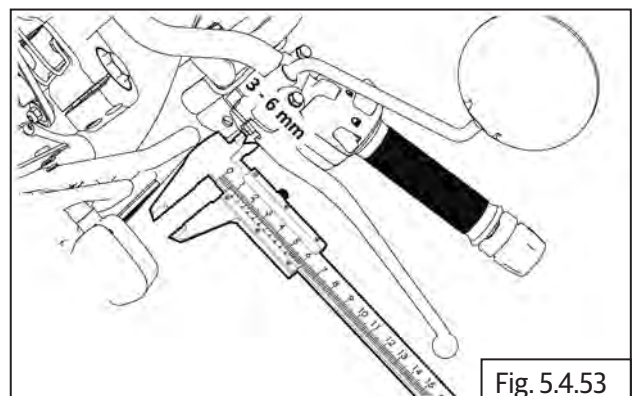
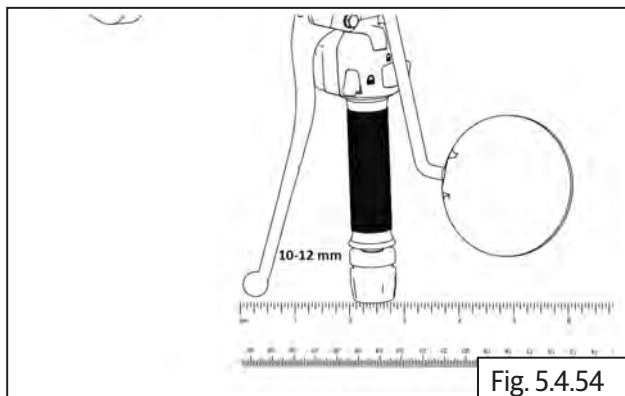

Fig. 5.4.53

- Position steering in straight position. Acutate clutch lever three times and check for free play of 10-16 mm.



- Ensure there is free hand movement at clutch actuating arm when the handlebar is at full left position

5.4.23. Battery Connections

NOTE

- Ensure ignition and stop switches are in OFF position before connecting battery cables.
- Connect battery positive (+) terminal **(a)** and tighten Hex head bolt **(M6)**.

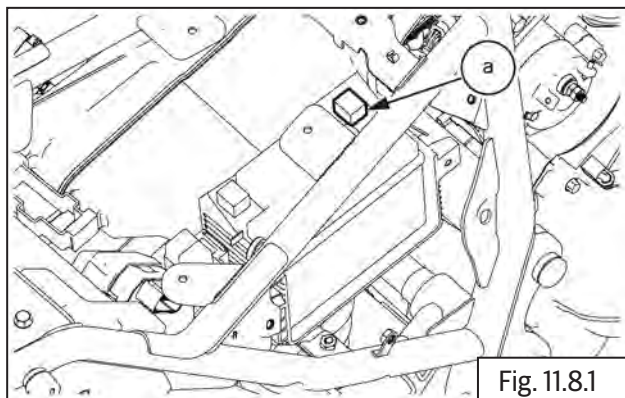

10 mm Double end spanner

- Connect battery negative (-) terminal **(a)** and tighten Hex head bolt **(M6)** in battery.

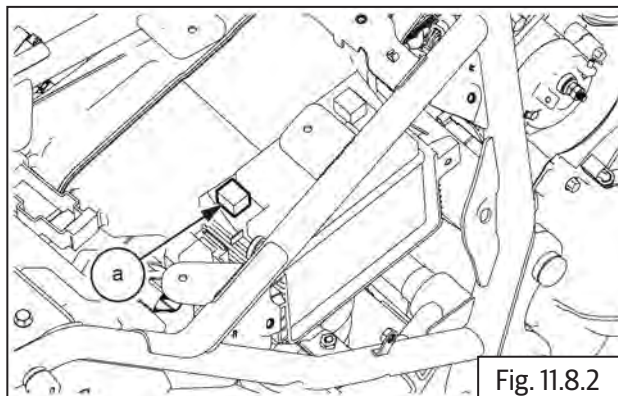

10 mm Double end spanner

- Clean and apply recommended agents on battery terminals.

5.4.24. Rider Seat Assembly on Frame

- Ensure mounting holes **(a)** of the seat are aligned with frame.

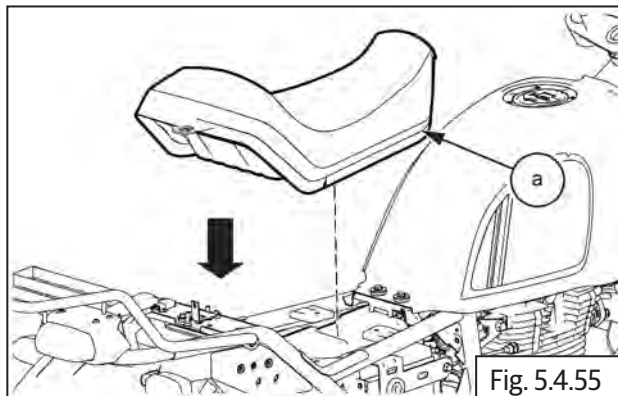

5.4.25. Pillion Backrest and Seat Assembly on Frame

- Locate the grab rail **(a)** over the pillion seat and make sure the holes are aligned.

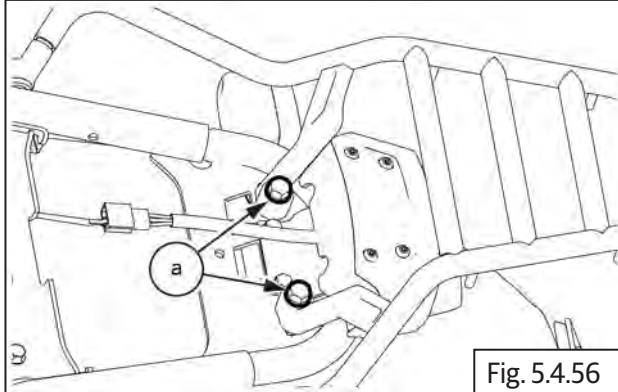

- Locate the pillion seat **(a)** over the frame.

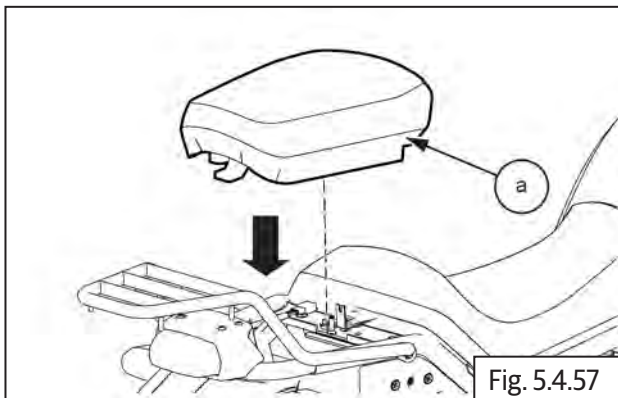

- Insert the bolts **(a)** and tighten it.

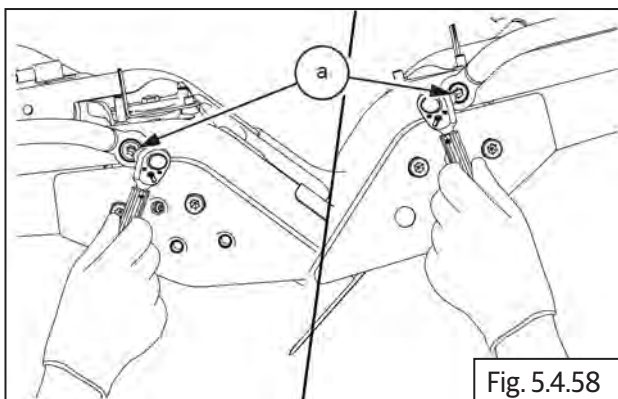

5.4.26. Side Panel LH

- Align LH panel to fit into frame **(a)** and lock it.

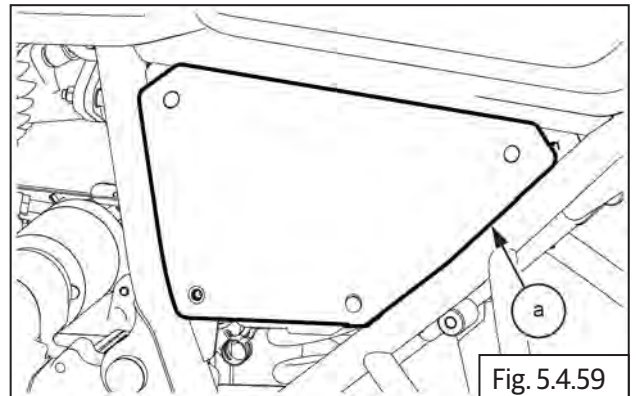

- Install 3 Nos. Hex socket button head screws **(a)** (except left bottom one).

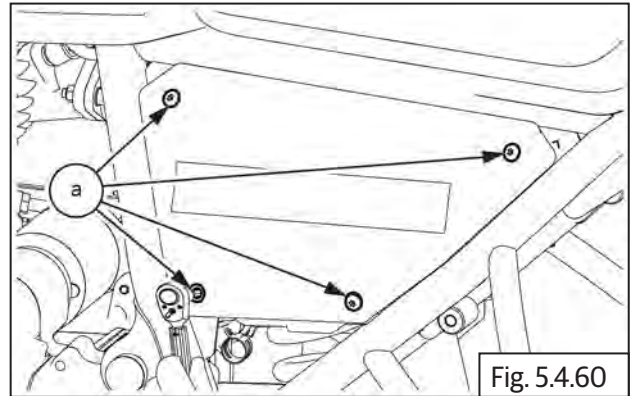

5.4.27. Side Panel RH

- Locate side panel RH into frame and lock in its position.

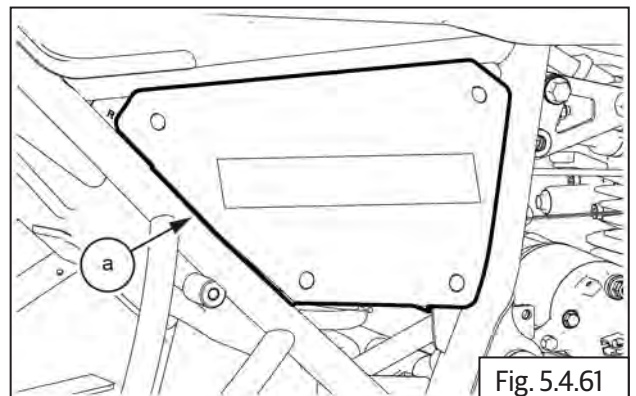

- Install 3 Nos. Hex socket button head screws **(a)** (except left bottom one)

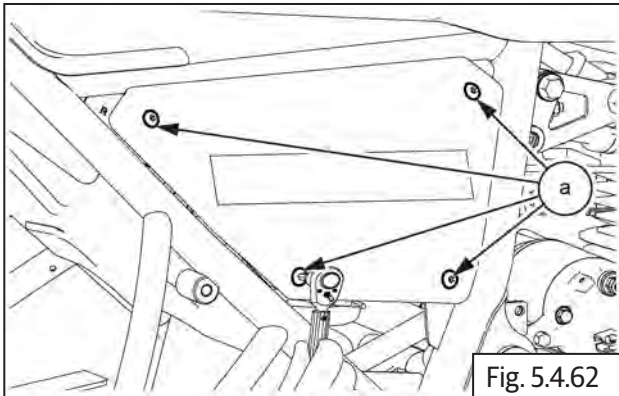

	5 mm Allen Key
---	----------------

5.4.28. Drain Bolt and Engine Oil Re-fill

- Insert strainer **(a)** into the frame.

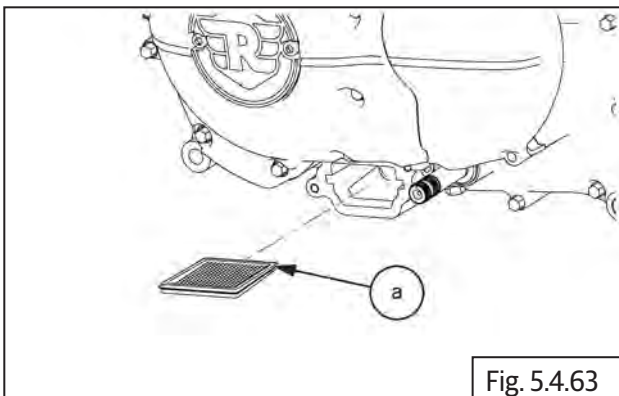

- Install O-ring **(b)** strainer cap **(a)**.

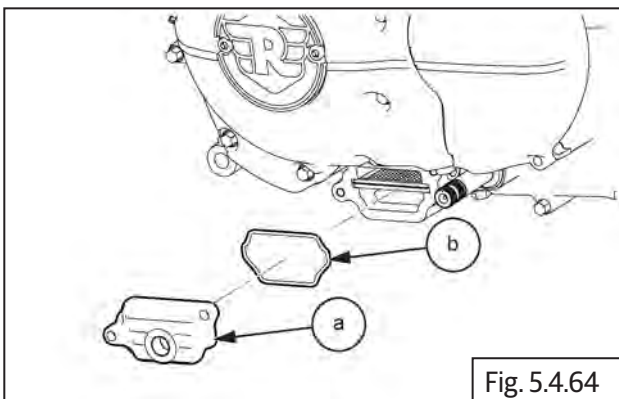

- Align and tighten the 2 Nos. bolt **(a)** **(M6)**

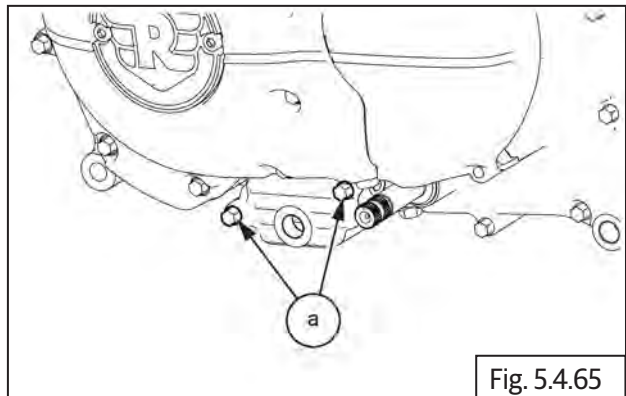

Dry Fill	2.5 Liters / 0.55 Imperial gallon
Grade	SAE 15W50 APISL, JASO MA2, SEMI SYNTHETIC

	8 mm Socket with Ratchet
Torque	8-12 N-m/0,8-1.2 kgf-m

- Refill engine oil with recommended quantity.
- Assemble engine oil filler cap **(a)**.

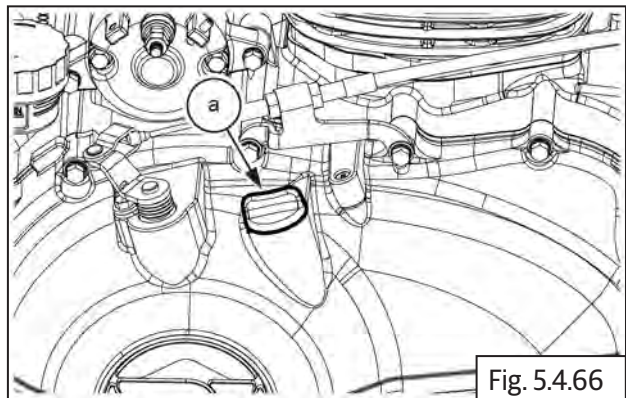

- Start and warm up engine for 2 to 3 minutes and then turn it off.
- Check oil level through oil level window.

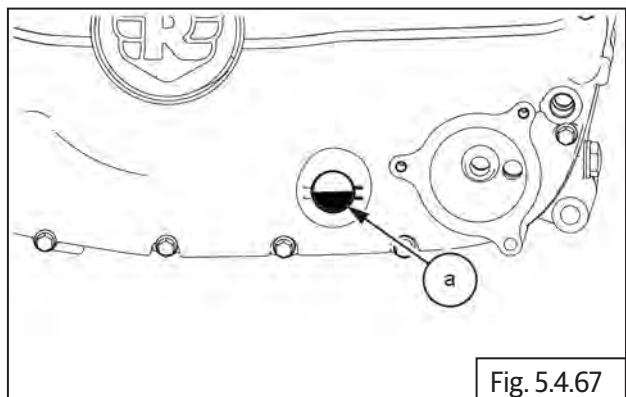

ENGINE INSPECTION

CONTENTS	PAGE
5.5 Engine Inspection	145
5.5.1. Cylinder Head	145
5.5.2. Cylinder Barrel	148
5.6.3 Crankcase	149
5.5.3. Clutch Components	150
5.5.4. Shifter Forks.....	151
5.5.5. Selector Drum.....	152

5.5 Engine Inspection

NOTE

- Remove off carbon deposits by scraping gently.
- Use soft blunt objects to clean.
- Wash components with recommended solvents.
- Ensure area is clean and dry before inspection.

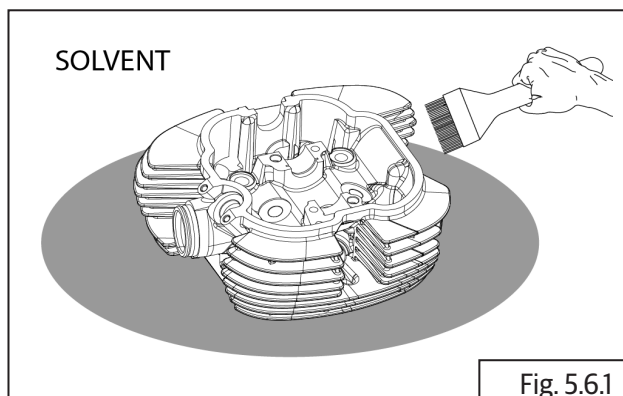

5.5.1. Cylinder Head

Cylinder Head Inspection

- Inspect cylinder head carefully for any cracks, blow holes or damages - especially in the inlet and exhaust ports.
- Place thick straight edge across cylinder head gasket seating surface.
- Insert pointed feeler gauge of 0.05 mm thickness between straight edge and cylinder head.
- Inspect and ensure 4 locations (**a, b, c, d**) on cylinder head are at same level.

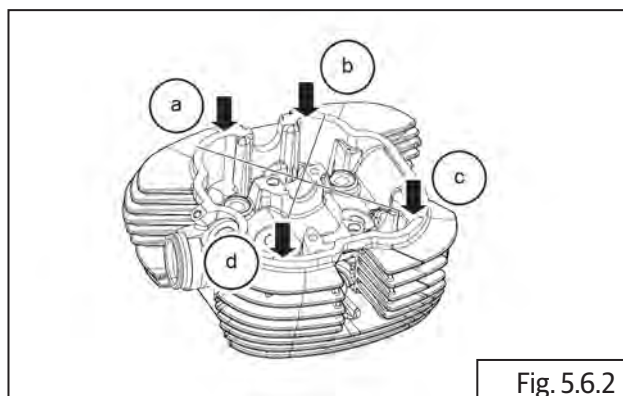

- Ensure feeler enters properly at marked places.

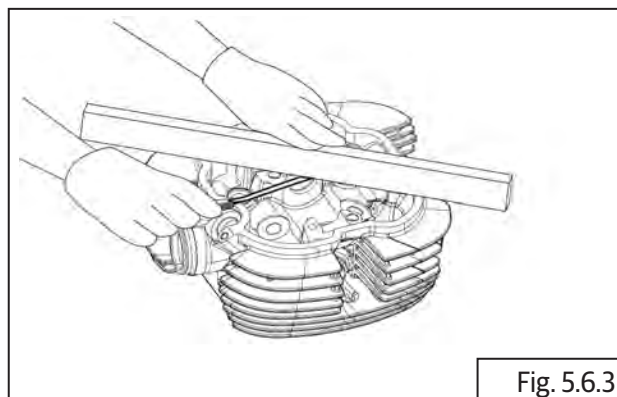

Thick straight edge and Feeler gauge

Service limit:	0.05 mm
----------------	---------

Rocker Cover to Cylinder Head Seating Surface

- Place the thick straight edge across the rocker cover gasket seating surface.
- Insert pointed feeler gauge of 0.05 mm thickness between straight edge and cylinder head at the marked places.

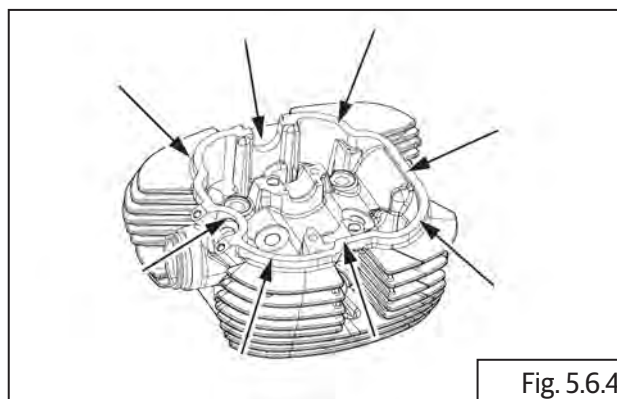

- Ensure feeler enters properly at marked places.

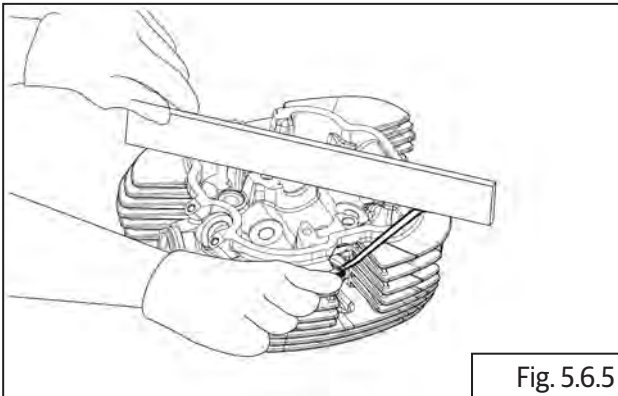

Fig. 5.6.5



Thick straight edge and Feeler gauge

Service limit:

0.01 mm

Rocker Cover

- Place thick straight edge across the rocker cover.
- Insert pointed feeler gauge of 0.05 mm thickness between straight edge and rocker cover.
- Inspect and ensure 4 locations **(a, b, c, d)** on rocker cover are at same level.

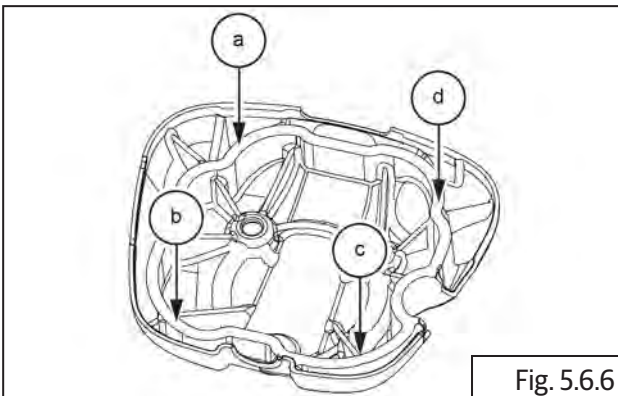

Fig. 5.6.6



Thick straight edge and Feeler gauge

Service limit:

0.05 mm

Camshaft Journal OD

- Measure camshaft journal OD **(a)**.

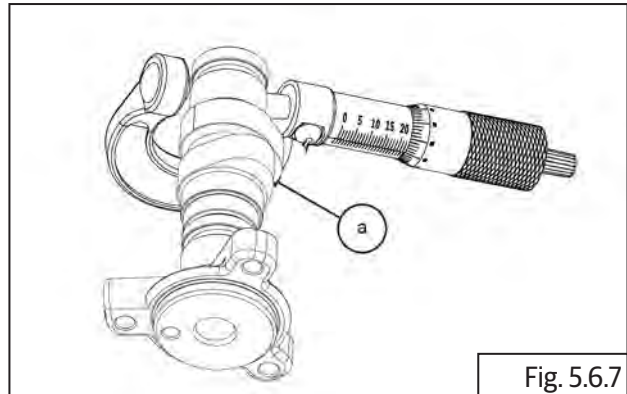

Fig. 5.6.7



Micrometer

Service Limit:

23.930 mm

Camshaft Lobe

- Inspect cam lobes for scoring, wear-out and scratches.
- Measure height of each cam lobe **(a)**.

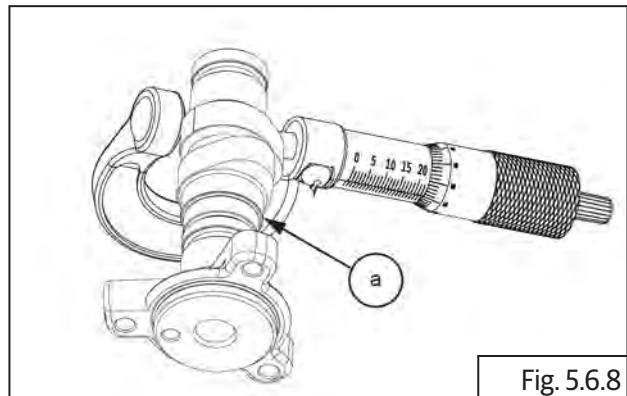

Fig. 5.6.8



Micrometer

Service limit (Intake):

35.460 mm

Service limit (Exhaust):

34.930 mm

Valve Inspection.

- Check each valve for wear, burn or distortion at its face and stem end. Replace valve, if necessary.
- Check valve stem end face for pitting and wear.
- When it is worn out, replace the valve.

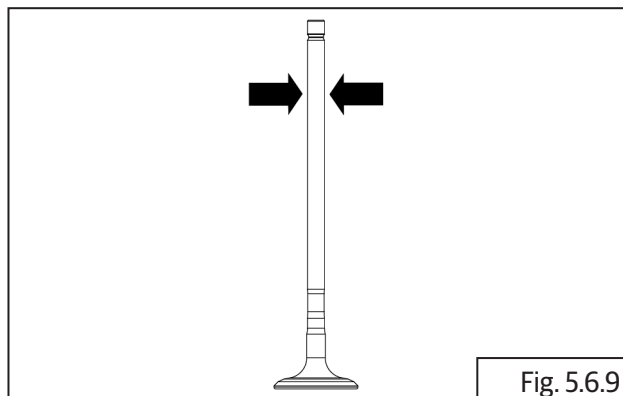

Valve Guide ID (Inlet and Exhaust)

- Using micrometer and bore gauge, measure the ID of the valve guides at the top and bottom working area inside the guides.

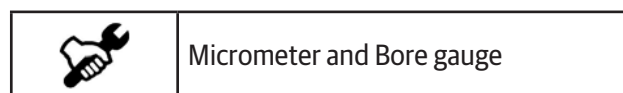
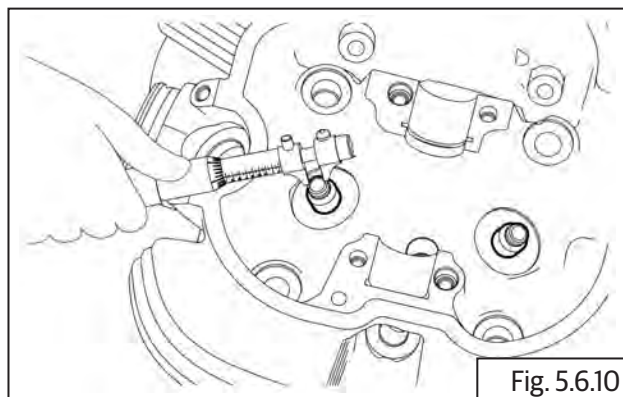

Service Limit Intake	6.070 mm
Service Limit Exhaust:	6.100 mm

Valve Spring (Inlet and Exhaust)

- Measure load on installed and working condition.

Installed Load	
Minimum:	154.100 N-m
Maximum:	174.100 N-m

Working Load	
Minimum:	431.300 N-m
Maximum:	461.300 N-m

Valve Stem OD (Inlet and Exhaust Valve)

- Measure diameter at marked places along the length of each stem.

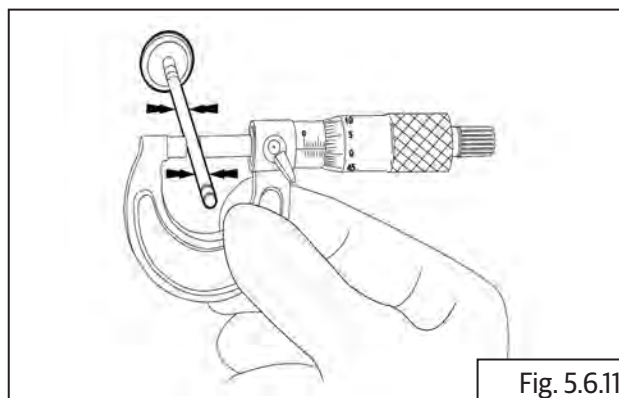

Inlet Valve Stem	
Measuring Point	Service Limit
Stem OD Top	5.945 mm
Stem OD middle	5.945 mm
Stem OD bottom	5.945 mm
Bend	0.010 mm

Exhaust Valve Stem	
Measuring Point	Service Limit
Stem OD Top	5.920 mm
Stem OD middle	5.920 mm
Stem OD bottom	5.920 mm
Bend	0.010 mm

5.5.2. Cylinder Barrel

Cylinder Barrel Bore ID

- Check cylinder bore to piston working area for scoring, seizure marks and/or excessive wear.
- Measure the cylinder bore at the top, middle and bottom at the rings working area using a bore gauge.
- Measure at both across and along the gudgeon pin axis.

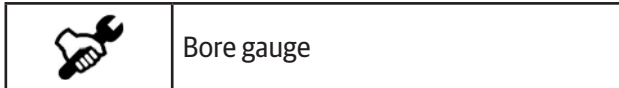
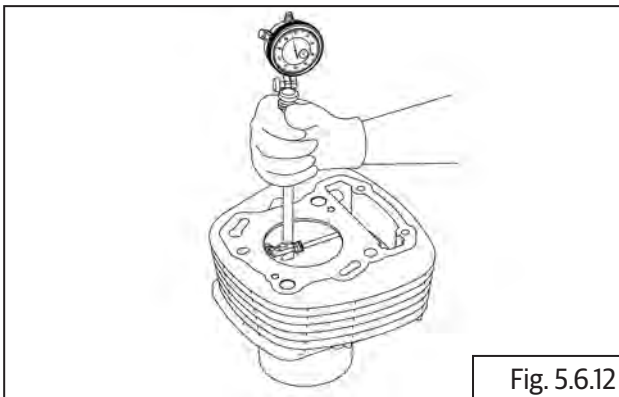

Measuring points	Service Limit
(ID) Top of Piston working area	72.09 mm
Top of Piston working area	72.09 mm
(ID) Middle of Piston working area	72.09 mm
(ID) Bottom of Piston working area	72.09 mm
Bottom of Piston working area	72.09 mm
Barrel Bore Service Limit	72.09 mm

Service Limit	72.09
---------------	-------

Piston OD

- Measure and record both LH and RH cylinder piston OD at three levels - Top, Middle, and Bottom using Micrometer.

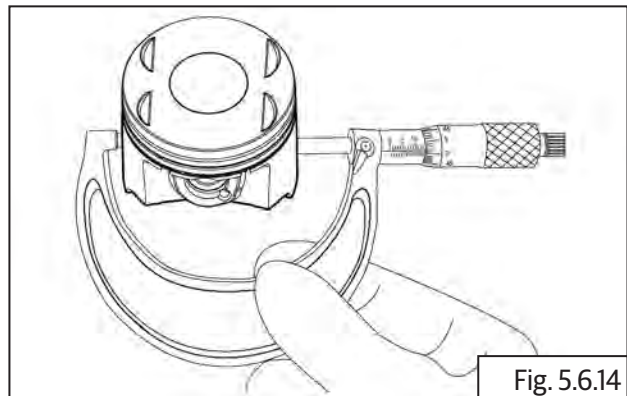
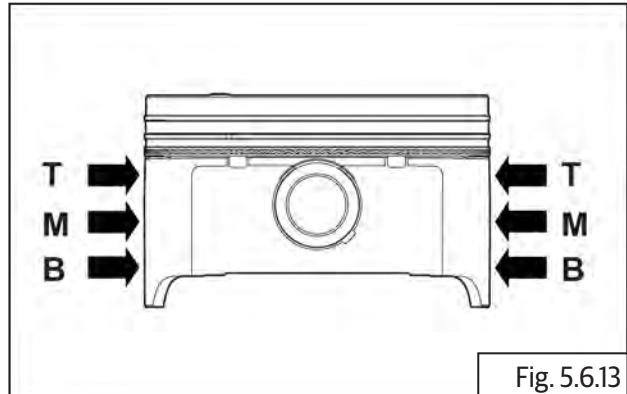

Service Limit	71.895 mm
---------------	-----------

Piston Pin Bore ID

- Measure both LH and RH cylinder piston pin bore (a) inner diameter using inside micrometer (b).

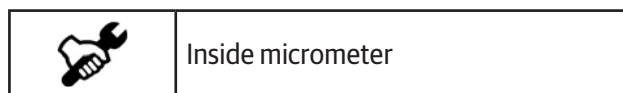
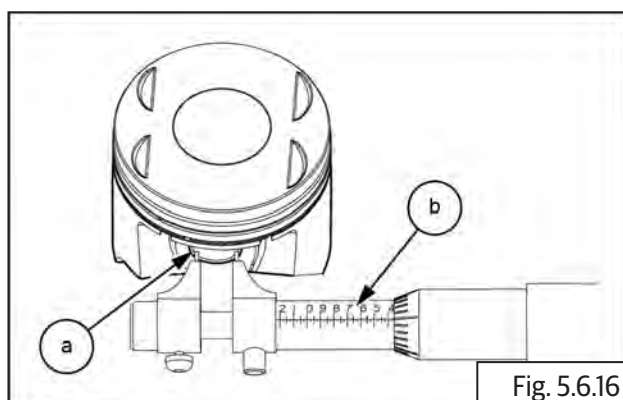
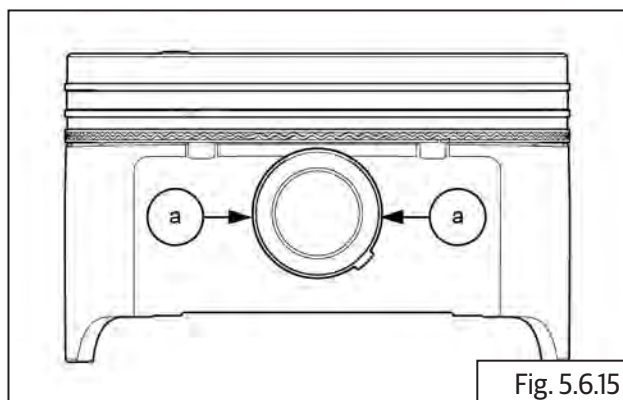

Service Limit	19.997 mm
---------------	-----------

Piston Ring End Gap

- Position the piston rings at their respective locations at the top of the cylinder barrel and ensure they are seated "squarely" inside the cylinder barrel.

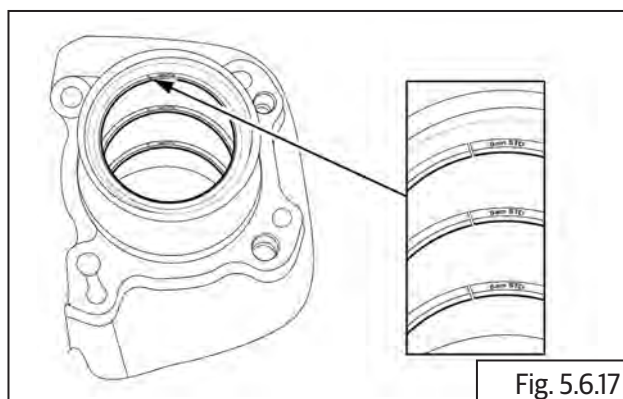

- Measure piston rings end gap (a) using feeler gauge (b).

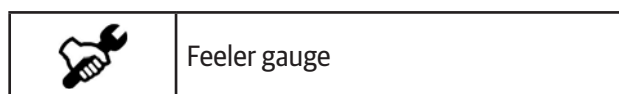
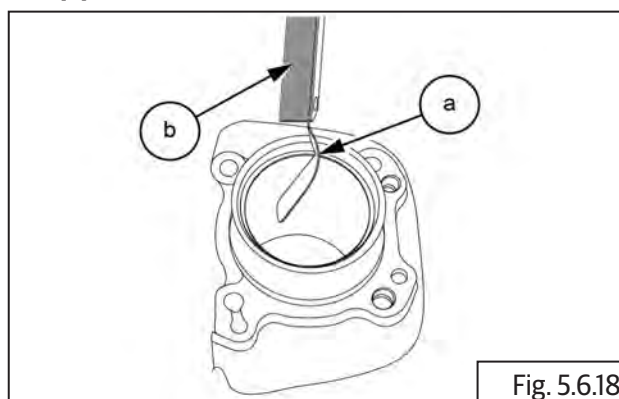

Measuring Points	Service Limit
Piston ring top 1	0.6mm
Piston ring top 2	0.7 mm

5.6.3 Crankcase

Connecting Rod Small End ID

- Measure the connecting rod small end inner diameter (a).

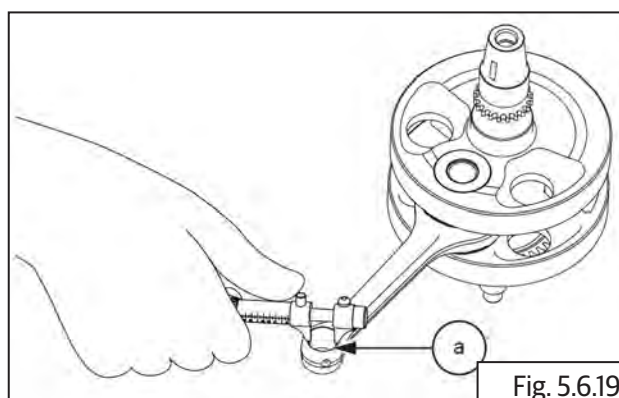

Service Limit	20.042 mm
---------------	-----------



5.5.3. Clutch Components

Friction plate

- Inspect the clutch plates visually for uneven wear, seizure and discoloration.
- Measure the thickness of the friction plate **(a)** at 4 locations marked by arrows.

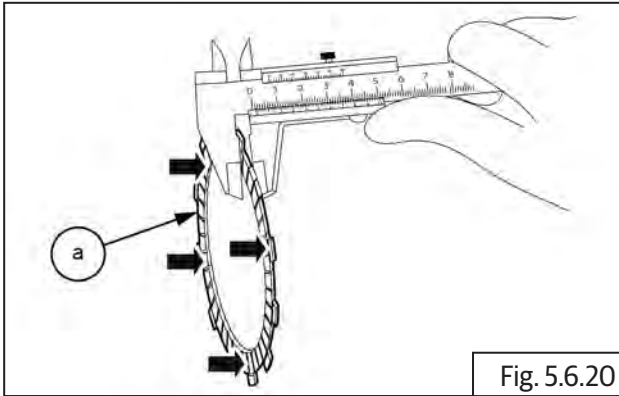

	Vernier caliper
---	-----------------

Service Limit:	2.80 mm
Bend	0.3 mm

Steel Plate

- Measure the thickness of the steel plates **(a)** at different locations.

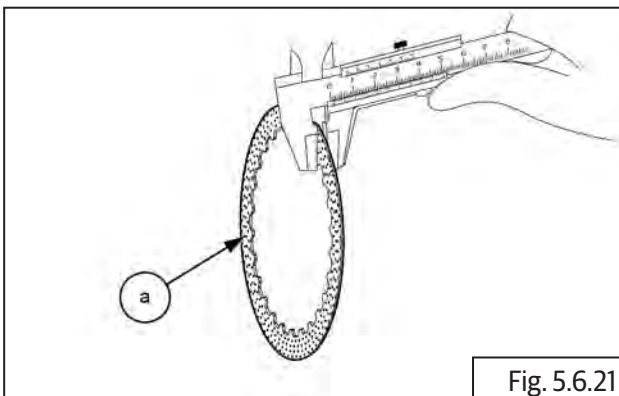

	Vernier caliper
---	-----------------

Service Limit:	1.50 mm
Bend	0.3 mm

Spring

- Measure the length of the spring in decompressed condition using a vernier caliper..

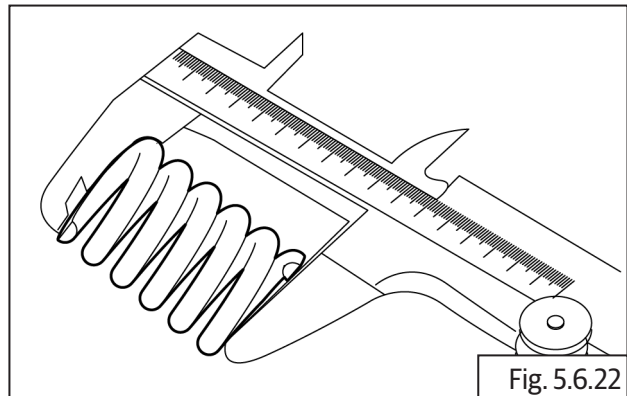



	Vernier Caliper
---	-----------------

Service Limit:	44.30 mm
----------------	----------

Clutch Hub Washer

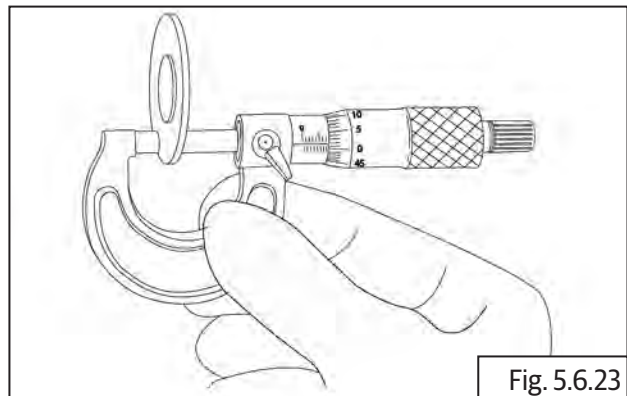
- Measure width of the washer using a micrometer.
- Make sure the washer is free of dents and burrs. Replace if found damaged.



	Micrometer
---	------------

Service Limit:	1.95 mm
----------------	---------

Center Clutch

- Inspect the clutch hub for any scratches, abnormal wear or damage of the lugs.

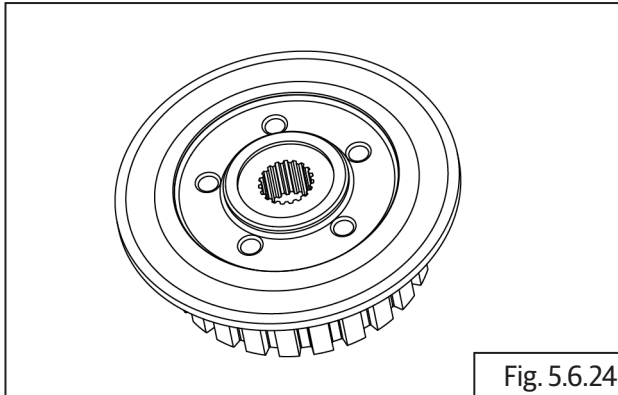

- Visually inspect outer component clutch center for any scratches, wear or damage.

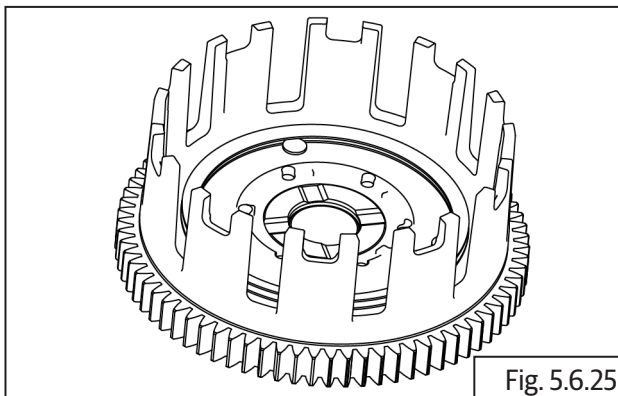

Pressure Plate

- Visually inspect pressure plate for any, wear, bends, lug breakage, heat marks or damages.

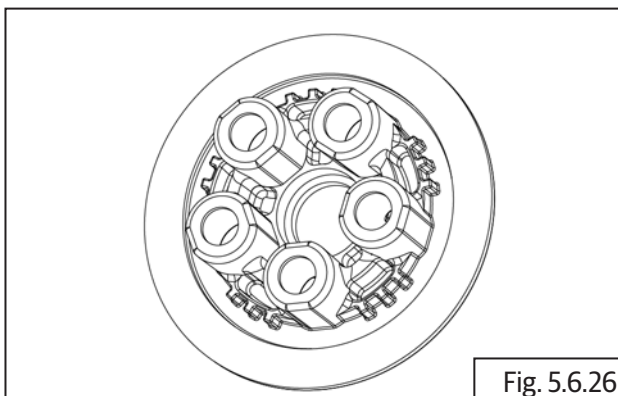

5.5.4. Shifter Forks

- Measure the pegs on shifter forks **(a)** using micrometer for wear.

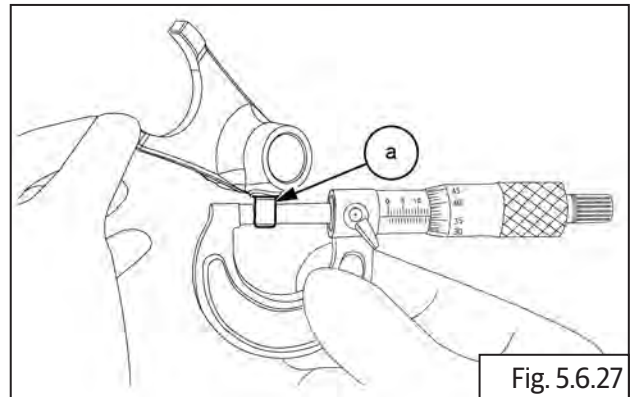

Micrometer

Service Limit:

7.80 mm

- Visually inspect the shifter fork machined lugs **(a)** for damage, excessive wear out scoring and replace if damaged.

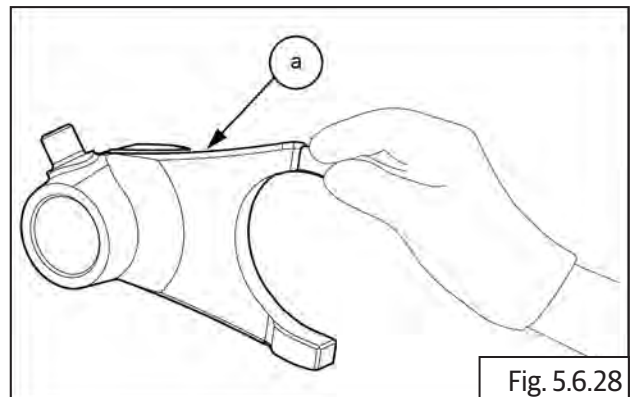

5.5.5. Selector Drum

- Inspect the shifter fork working grooves in the selector drum for any damages, chipped ends etc. Measure the grooves in their working area for excessive wear out.

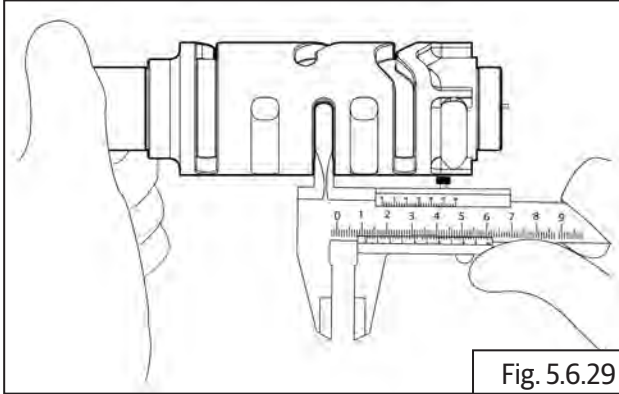

Service Limit:	7.90 mm
----------------	---------

CHASSIS

6.CHASSIS

CONTENTS	PAGE
6.1. AIR FILTER BOX ASSEMBLY	156
6.2. CONTROL CABLES	163
6.3. HANDLEBAR	176
6.4. EXHAUST PIPES AND SILENCERS.....	186
6.5. FOOTRESTS/STANDS/SAREEGUARD	192
6.6. MUDGUARD AND NUMBER PLATES.....	199
6.7. SIDE PANELS AND RIDER SEAT	206
6.8. WHEELS.....	212
6.9. SUSPENSION.....	237
6.10. SUBFRAME	266
6.11. TROUBLESHOOTING	274

AIR FILTER BOX

CONTENTS	PAGE
6.1 Air Filter Box	157
Dismantling	157
6.1.1. Air Filter Element from housing.....	157
6.1.2. Air filter Housing from frame.....	158
Inspection	158
Assembly	159
6.1.3. Air filter housing on frame.....	159
6.1.4. Air filter Element into housing	160

6.1. Air Filter Box

Dismantling

6.1.1. Air Filter Element from housing

- Remove 3 hex socket button head screws **(a)** (M5) from the LH side panel (Left bottom is a dummy).
- Pull out the side panel gently to release from the grommet in the frame:

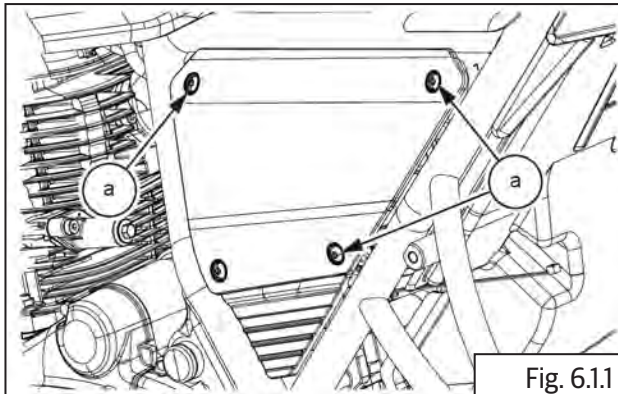

Allen Key 4mm

- Pull out the canister hoses **(a)** and **(b)** from the calmps.

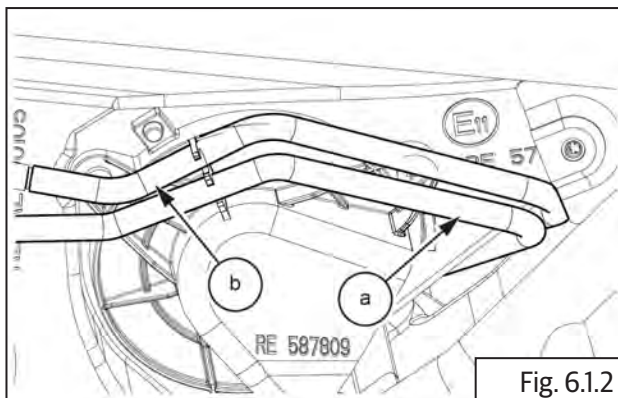

- Loosen and Remove the 3 Pan head screws **(a)** (M5) from the air filter cover.

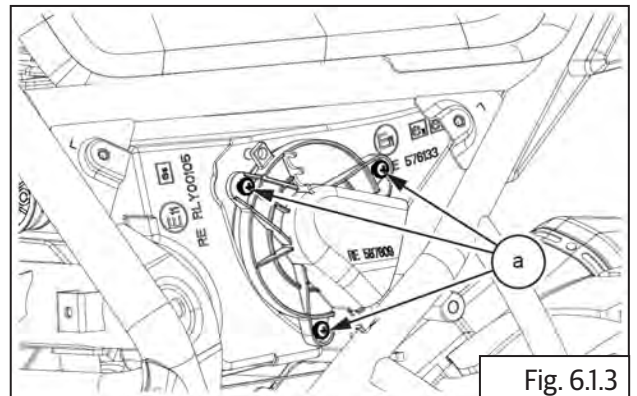

Allen Key 4mm

- Remove Cover **(a)**.

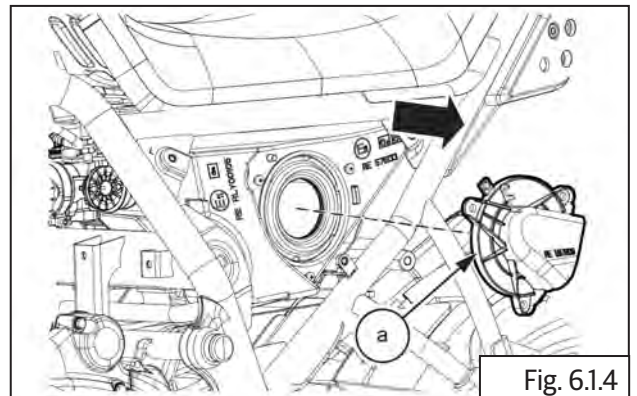

- Remove air filter element from housing.

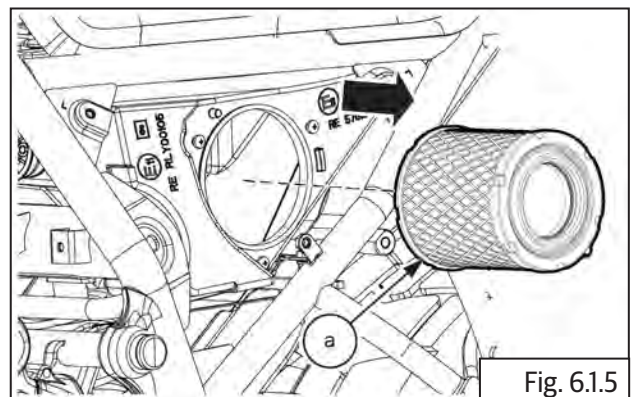

6.1.2. Air filter Housing from frame

- Remove the canister. (Refer caniser dismantling)
- Disconnect battery terminals and remove from air filter housing. (refer electricals section for dismantling battery)
- Remove 2 flanged hex bolts **(a)** **(M6)** and remove mudguard.

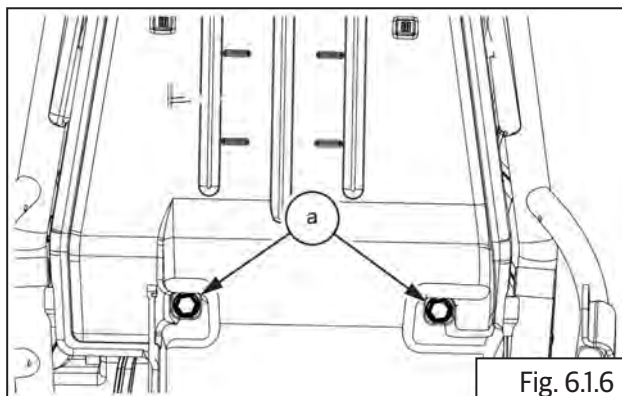

10 mm Socket with Ratchet

NOTE

Ensure the wiring connections are removed.

- Disconnect breather hose from air filter housing.
- Loosen throttle body worm clip sufficiently.
- Remove RR unit with its rubber holder from air filter housing.
- Loosen and remove 3 flange hex bolts **(a)** **(M8)** holding the cross bar below air filter housing to frame.

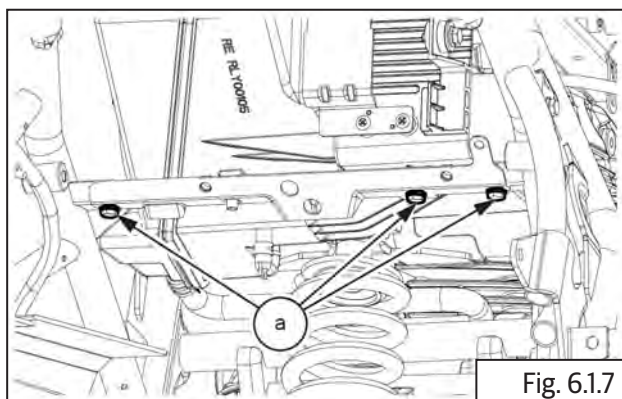

12mm Socket and Ratchet

- Remove cross bar **(a)** from bottom of the frame.

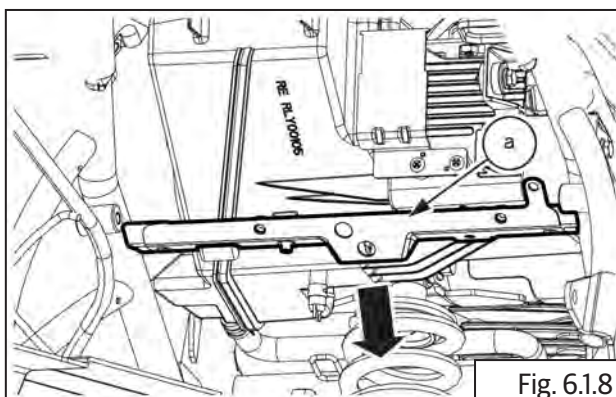

- Remove air filter housing from rear side of the frame.

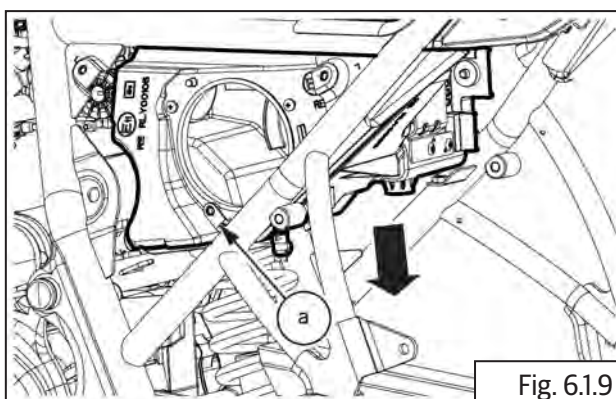

Inspection

- Inspect air filter box assembly for any damages or cracks
- Inspect air intake bellows for any damages, cracks and/or brittleness of the bellows.
- Inspect rubber seals, hoses for cuts, cracks or damages. Replace seals and rubber parts whenever they are removed.
- Inspect air filter element carefully for any deformation, damages, heavy clogging with dirt, soggy condition, and/or foreign particles embedded in the element. Replace if any of these conditions are observed

Clean

- Clean air filter element (a) after first 500 Kms (300 Miles) and later based on the periodic maintenance schedule OR more frequently if motorcycle is used in dusty/off-road conditions.
- Gently tap filter element (a) with minimum force to dislodge heavy/embedded dust particles.
- Using low pressure compressed air, blow air from out side to inner side to remove fine dust particles.

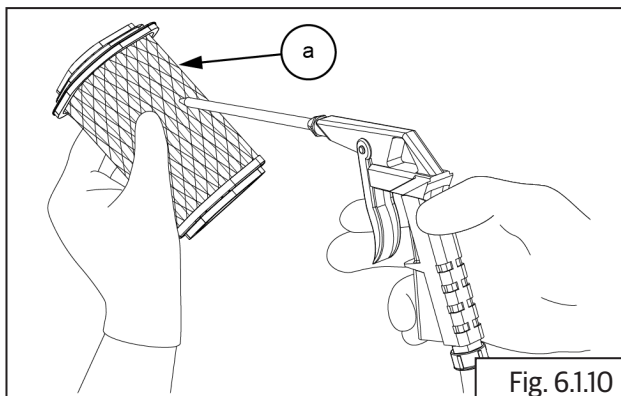

CAUTION
DO NOT wash the element in water, gasoline or any solvents.

- Clean the air filter housing internals, with a soft damp cloth to remove dust.

Replace

- Replace all O-rings, rubber beadings, seals, gaskets, rubber parts etc., whenever air filter assembly is serviced.
- Replace air filter element every 20,000 Kms 12,000 Miles) or earlier if motorcycle is used in dusty/off road conditions.

Assembly

6.1.3. Air filter housing on frame

- Position air filter housing (a) on frame from rear side.

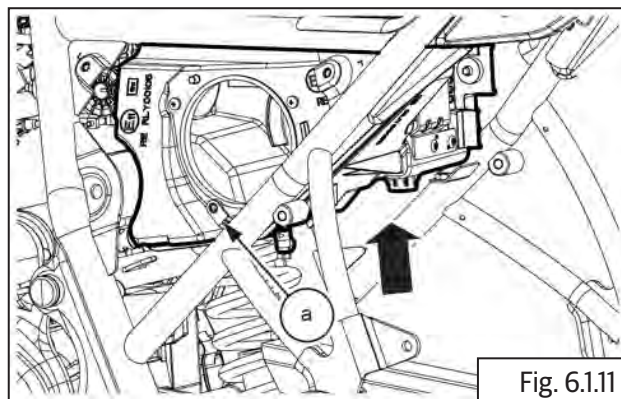

- Locate cross bar (a) under air filter housing.

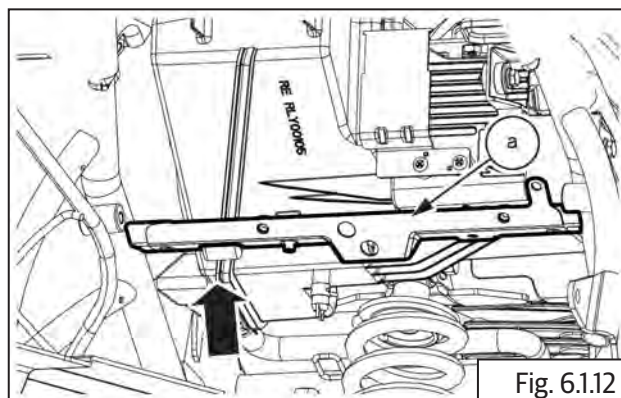

- Install 3 flange hex bolts (a) (M8) on the cross bar and install the air filter housing to the frame.

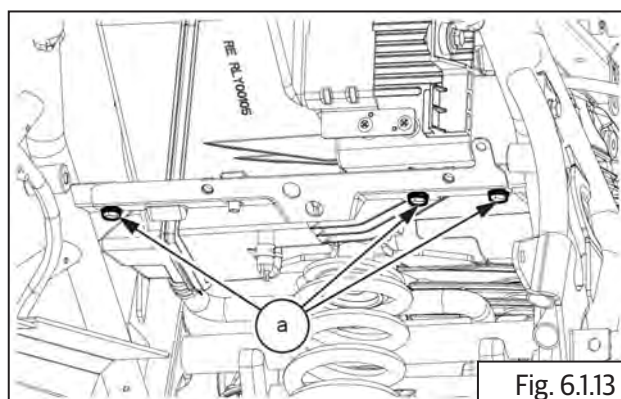

	10 mm Socket with Ratchet
Torque	10-12Nm(1.0-1.2 KgM.)

- Align mudguard and install using 2 flanged hex bolt **(a)** (M8) at bottom.

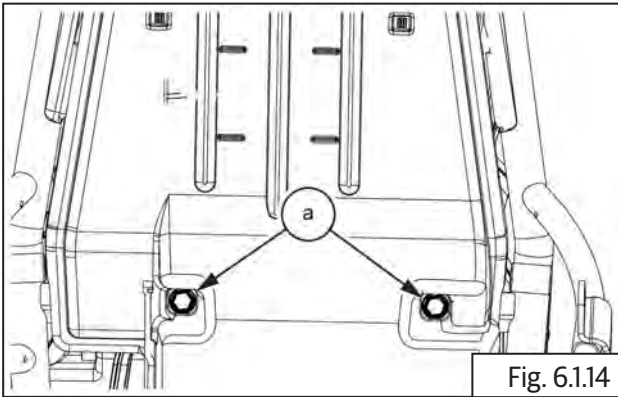

Fig. 6.114

- Locate cover on the air filter housing by aligning three mounting holes.

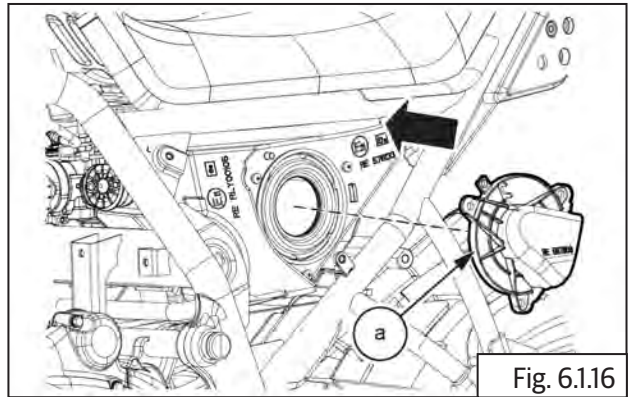

Fig. 6.116

	10 mm Socket with Ratchet
Torque	10-12Nm(1.0-1.2 KgM.)

- Install air filter cover with 3 screws **(a)**.

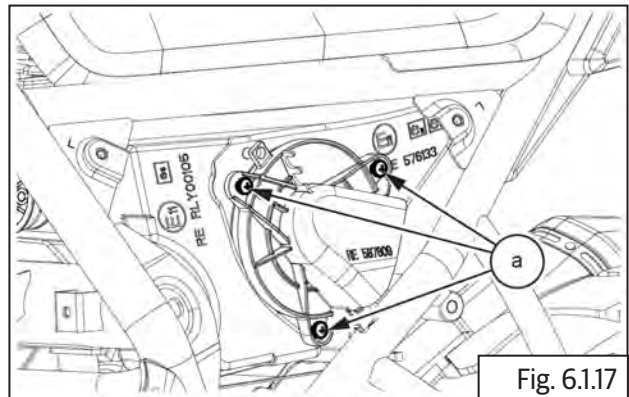

Fig. 6.117

- Assemble battery, connect terminals, locate battery in housing. (Refer electricals section for battery assembly).
- Install the canister (Refer canister assembly)

6.1.4. Air filter Element into housing

- Align air filter element in housing such that the open end of the element is facing outside.

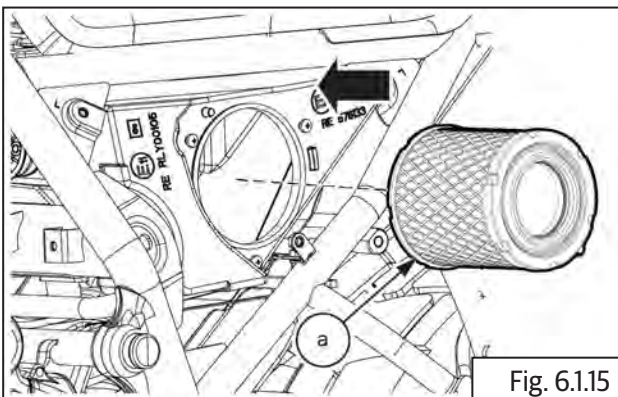

Fig. 6.115

	Philips head screw driver
--	---------------------------

- Connect canister hoses **(a)** and **(b)** to the clamps on the air filter cover.

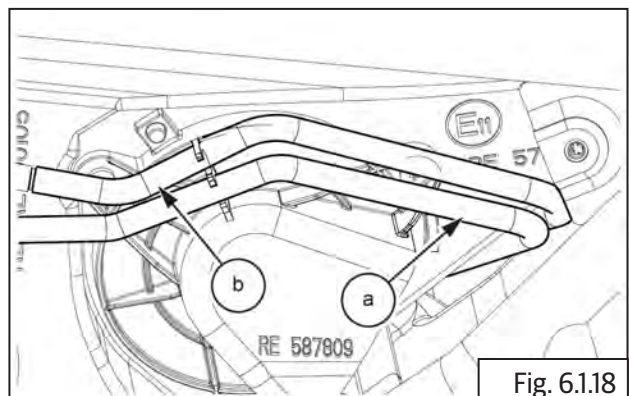

Fig. 6.118

- Locate the side panel **(a)** on the air filter assembly.

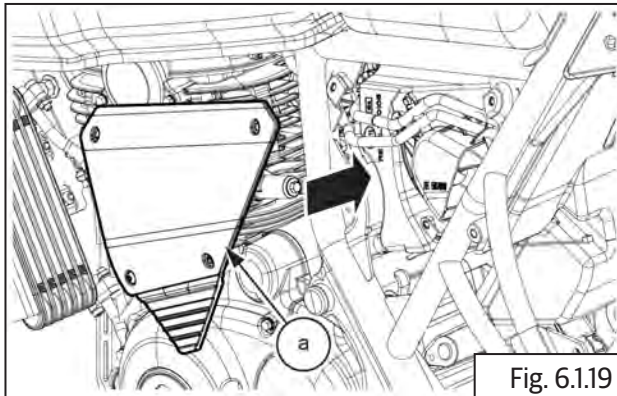

Fig. 6.1.19

- Install side panel using 3 hex socket button head screws.

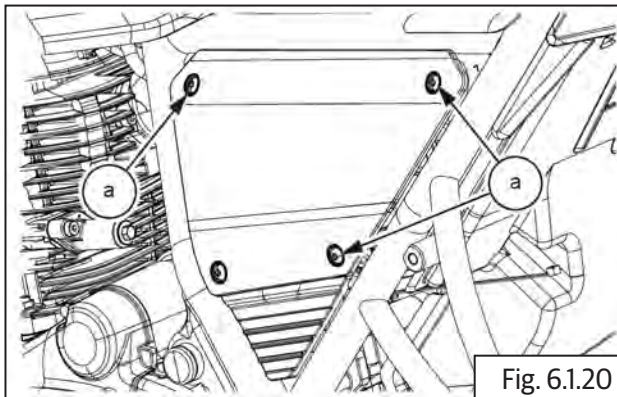

Fig. 6.1.20



Allen Key 4mm

CONTROL CABLES

CONTENTS	PAGE
6.2 Control Cables	164
Dismantling.....	164
6.2.1. Clutch Cable	164
6.2.2. Throttle Cable.....	165
Inspection	167
Assembly	168
6.2.3. Throttle Cable.....	168
6.2.4. Throttle Cables Free Play Adjustment.....	170
6.2.5. Clutch Cable	170
Troubleshooting.....	173

6.2 Control Cables

Dismantling

6.2.1. Clutch Cable

Cover RH End

CAUTION

Ensure the motorcycle is upright on a firm and flat surface.

- Ensure ignition switch and engine stop switch are in OFF position.
- Loosen lock nut and ensure adjuster **(a)** at the handlebar end is fully turned into the bracket LH to increase cable play.

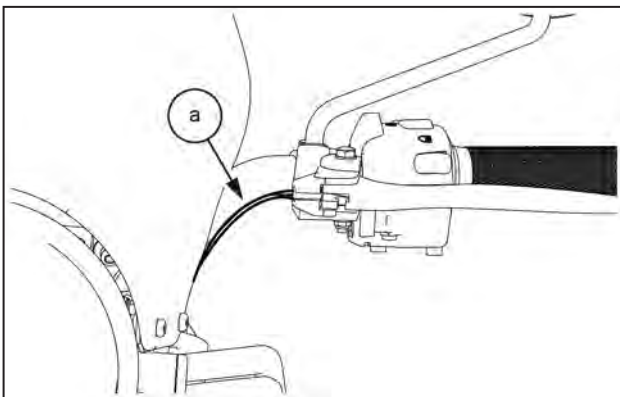

- Loosen outer locknut **(M8) (a)** completely on the clutch cable adjuster at RH cover end and push clutch cable **(b)** into cable guide in cover RH to increase the free play of the inner cable.

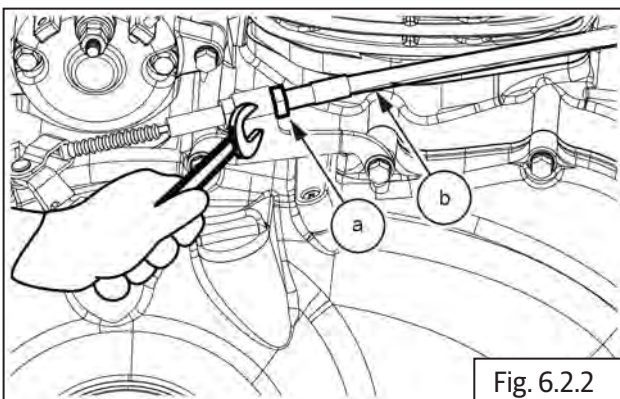

Fig. 6.2.2

- Gently push inner cable **(a)** into clevis **(b)** in clutch shaft **(c)** and remove cable through the slot in the clevis.

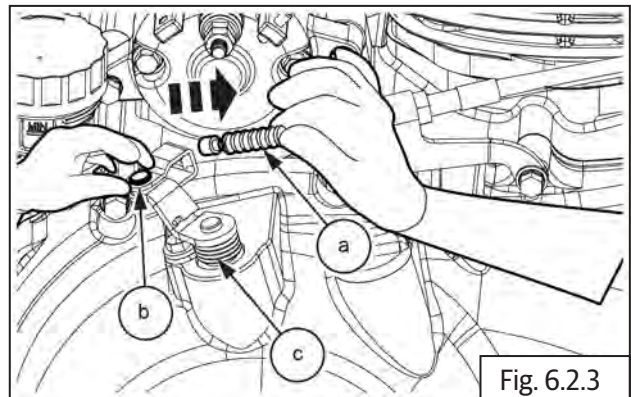

Fig. 6.2.3

- Remove protective rubber boot **(a)** from clutch cable **(b)**.

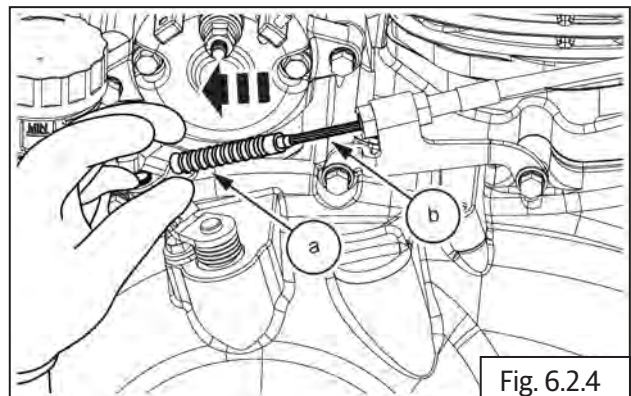

Fig. 6.2.4

- Loosen adjuster nut **(a)** completely from the clutch cable and remove.

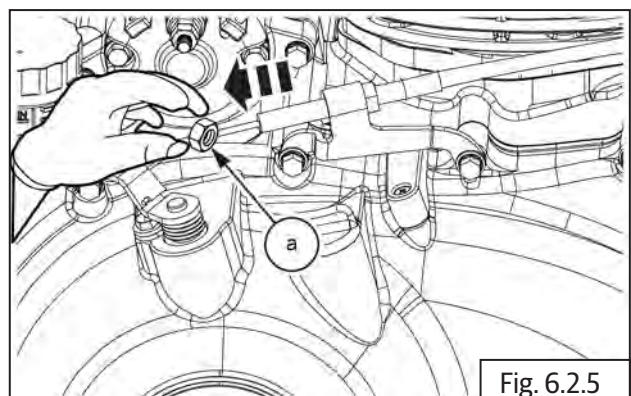
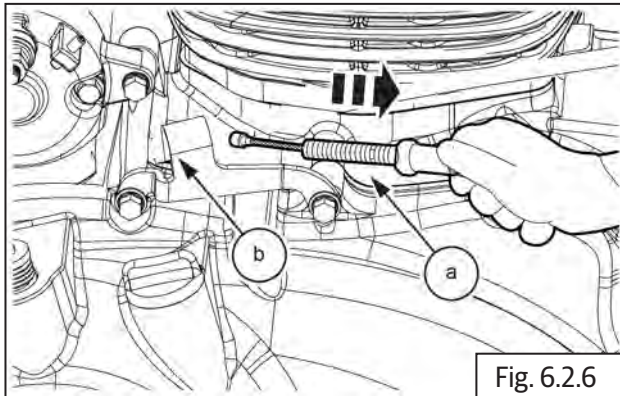

Fig. 6.2.5



12 mm Double end spanner

- Gently pull out clutch cable assembly **(a)** from the cable guide **(b)** in cover RH assembly.



Handlebar End

- Ensure the slot in the adjuster **(a)** and locknut **(b)** are aligned with the slot in the clutch bracket.

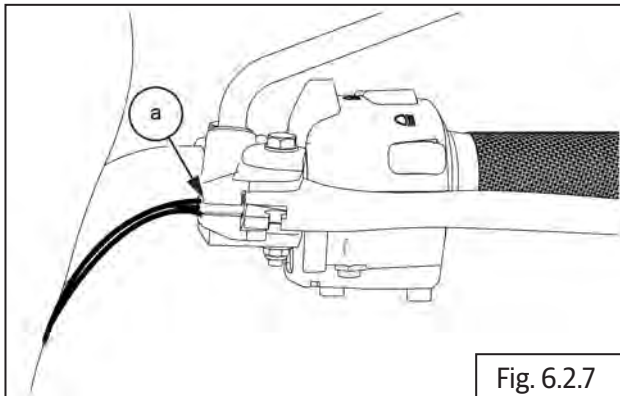

- Gently pull out the outer cable **(a)** from the adjuster. Rotate and align adjuster with slot in clutch bracket and release inner cable **(b)** from lever eyelet.

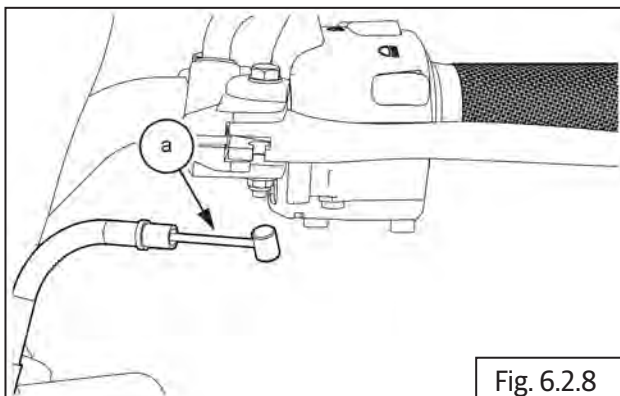

- Remove clutch cable from motorcycle.

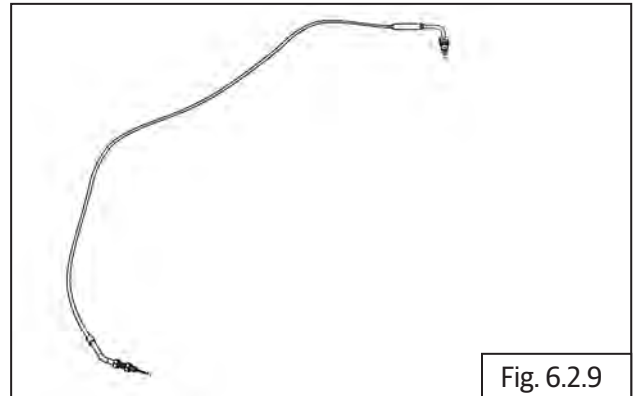

6.2.2. Throttle Cable

Throttle Body End

⚠ CAUTION

Ensure the motorcycle is upright on a firm and flat surface.

- Ensure Ignition switch and Engine stop switch are in OFF position.
- Remove side panel LH ([Section 6.7.1](#)).
- Remove rider seat ([Section 6.7.2](#)).
- Loosen fuel tank assembly mountings ([Section 7.1.1](#)) and carefully slide and lift fuel tank up to access 2 clips holding the throttle cables to frame on RH side.
- Loosen 2 Nos. Hex nuts **(M6)** **(a)** fully on top of throttle cable bracket **(b)** to increase inner cable **(c)** free play.

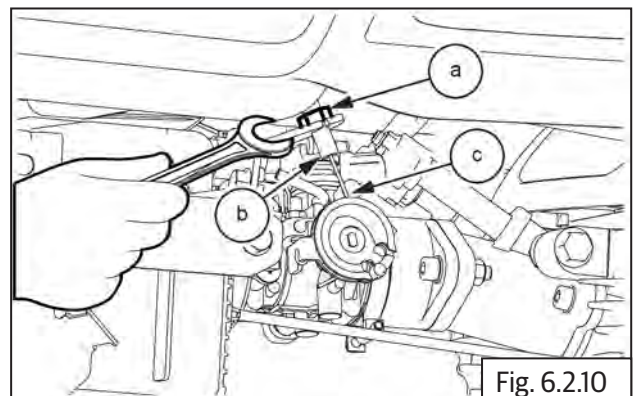

10 mm Double end spanner

- Push cable adjusters fully into the bracket and loosen the 2 inner hex nuts (**M6**) on the throttle cable adjusters.
- Ensure both inner nuts are free from the adjusters and gently pull out the adjuster of the inside cable till it is out of the bracket and slide the inner cable (**a**) out through the slot in the bracket.

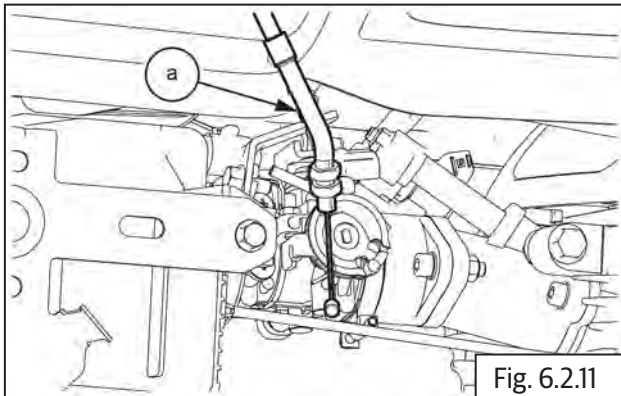
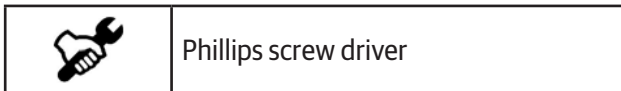
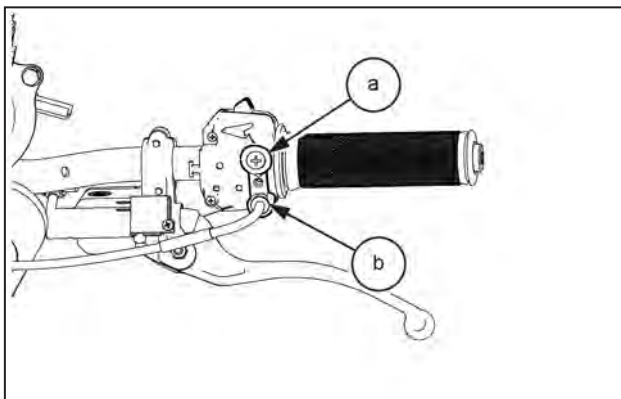

Fig. 6.2.11

Handlebar End

- Loosen screw (**a**) on the cable and rotate the clip (**b**) holding throttle cable to throttle rotor housing.



Phillips screw driver

- Loosen and remove 2 Nos. Phillips head screws (**a**) from the bottom of the throttle rotor housing and separate the halves.

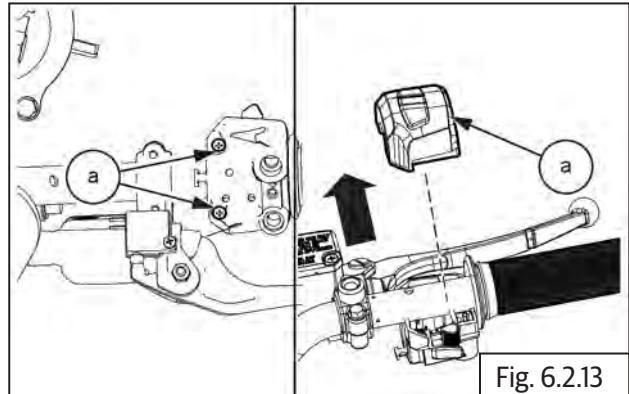

Fig. 6.2.13



Phillips screw driver

- Gently pull up the inner cable (**a**) from the slot in the throttle rotor (**b**), rotate and ensure it is aligned to the slot in the throttle rotor grip and remove.

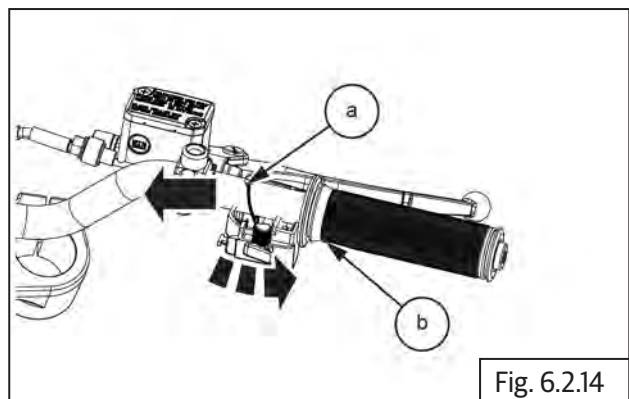

Fig. 6.2.14

- Loosen and remove Allen bolt (**a**) and remove the clamp (**b**).

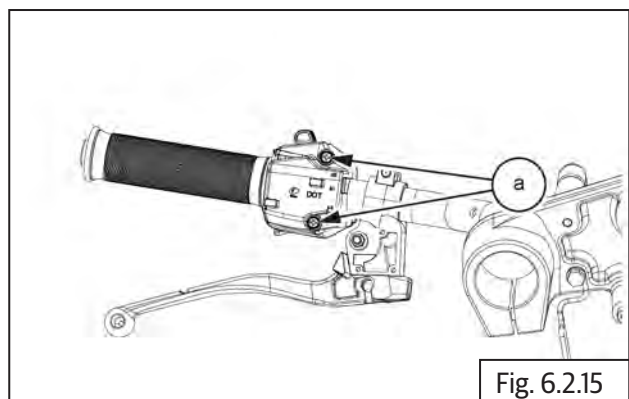

Fig. 6.2.15

- Remove the throttle cable.

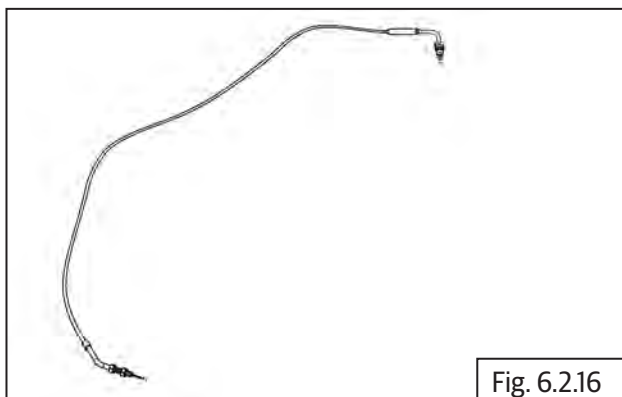

Fig. 6.2.16

Inspection

Cables

- Clean and inspect inner cables top and bottom ends for frayed and/or broken strands.

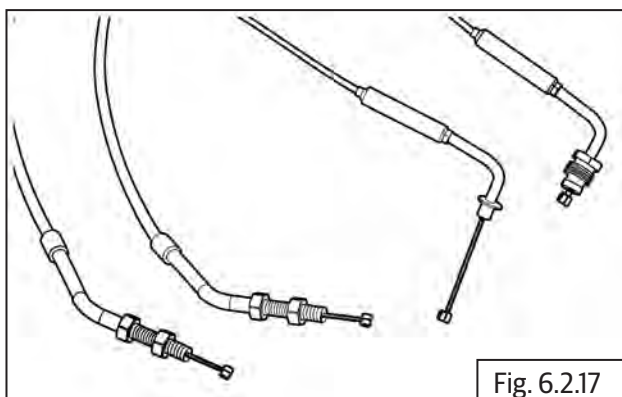

Fig. 6.2.17

- Clean and inspect outer cables for brittleness, damages and/or cracks.

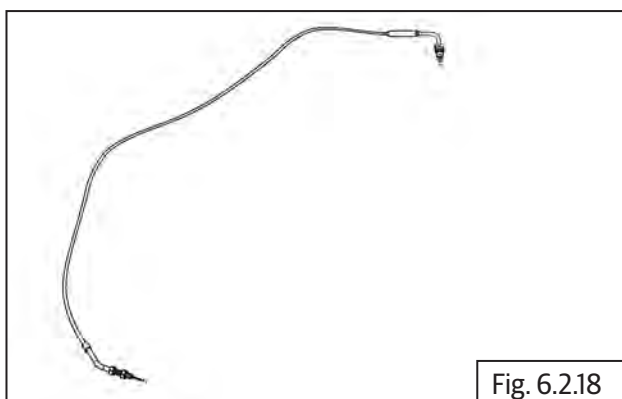

Fig. 6.2.18

- Inspect the cable adjuster threads and hex nuts for any wear out and/or damage.
- Check free movement of the inner cables in the outer cables and no stickiness.
- Replace control cables as per the recommendations in the maintenance chart.

⚠ CAUTION

DO NOT wash control cables, especially inner cables, using any solvents since it will damage the protective layer inside the control cables.

Do not lubricate inner cable by spraying any lubricants into the outer cable.

Do not roll the cables into a tight wind for storing after removal. Store them as straight as possible to avoid damage to the inner layer/cable.

Use a soft cloth with a mild cleaning agent if necessary, to wipe off the dirt, grease or grime on the outer cables.

Clutch Lever Bracket Adjusting Screw And Clutch Lever

- Inspect the cable seating area in the adjuster on clutch lever bracket for any damages/cracks.
- Inspect the threads of the adjuster and the clutch lever bracket for any damages, threads wear out.

Throttle Rotor, Grip and Housing on Handlebar RH

- Inspect throttle rotor grip for any damages and/or cracks.
- Inspect throttle rotor for any damages/wear out.
- Inspect cable seating eyelets in the throttle rotor for any damages, fraying etc.
- Inspect the throttle rotor movement slots in the top and bottom housing for any damages/wear out.

Assembly

6.2.3. Throttle Cable

- Route the cable **(a)** between the top yoke and frame head tube on the LH side under fuel tank.

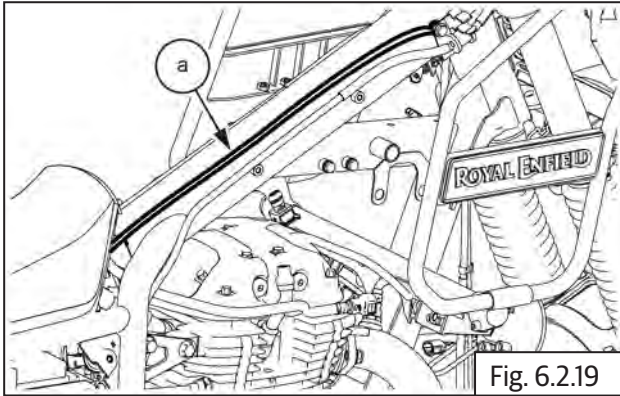

- Locate grooves provided on the **(a)**. Route the cable through the grooves in the frame.

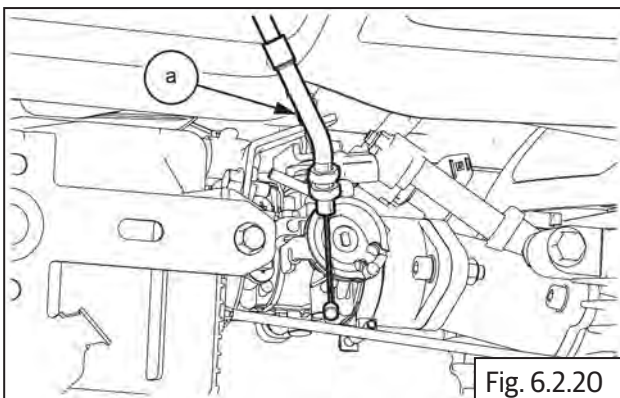

Handlebar End

- Lubricate throttle rotor grip inside with general purpose grease and assemble on handlebar RH.
- Ensure the cable slots on the rotor are facing above for correct and ease of assembly of inner cables.

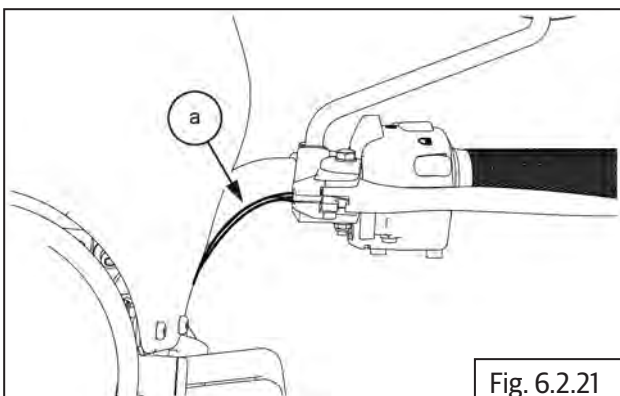

- Ensure the adjusters on cable is set at their center for finer adjustments later.
- Insert throttle cable **(a)** into the hole of the throttle rotor housing and locate inner cable in the eyelet on the throttle rotor.
- Align inner cable to the slot in the rotor, rotate and ensure proper routing of the inner cable in the slot in throttle rotor **(b)**.

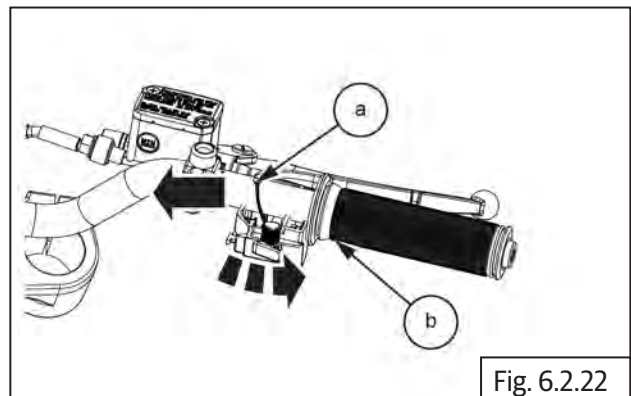

- Align inner cable to slot in the rotor, rotate and ensure proper routing of the inner cable in the slot in throttle rotor.

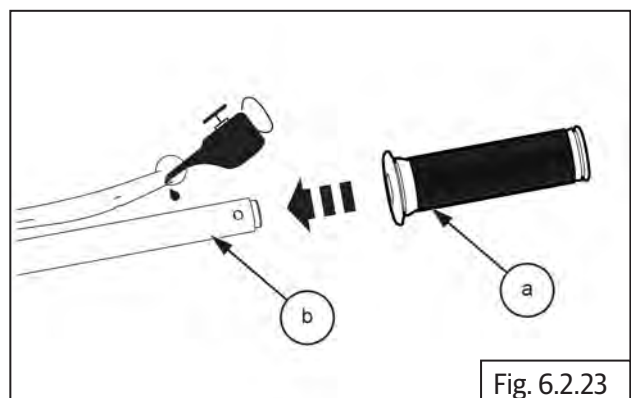

- Locate and hold bottom housing against handlebar such that the throttle rotor is correctly seated in the groove in the bottom housing.
- Rotate throttle rotor clockwise, till it is resting on the bottom housing.
- Locate the top housing on the handlebar above the rotor, duly ensuring the following:
 - Throttle rotor is correctly seated in the groove in the top housing.
 - The locking peg in the top housing is located correctly into the hole in the handlebar.
 - The seating faces of the housing are matched correctly.

- Support top and bottom housings, check for free movement of the throttle rotor by gently rotating the throttle rotor grip.
- Insert Phillips head screws **(a)** into the mounting hole in bottom housing and tighten just sufficiently.

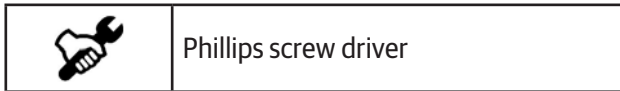
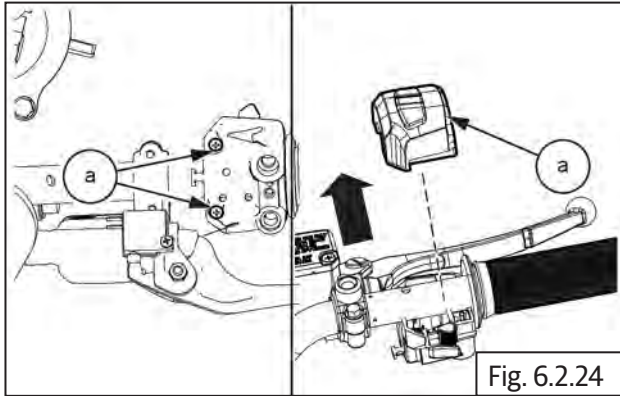

- Check and ensure rotor housing is locked properly in handlebar and free movement of throttle rotor and tighten both screws evenly till the housing is tight on the handlebar.

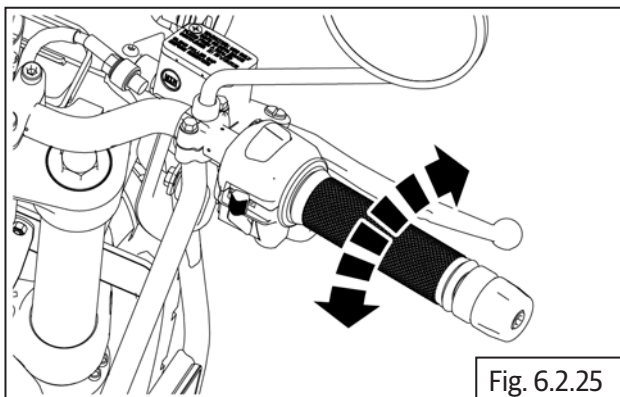

- Rotate clip **(a)** such that the groove is duly positioned on the cable and tighten locking screw **(b)**.

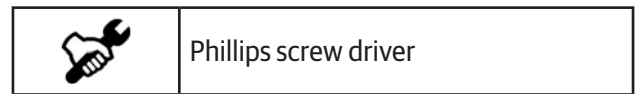
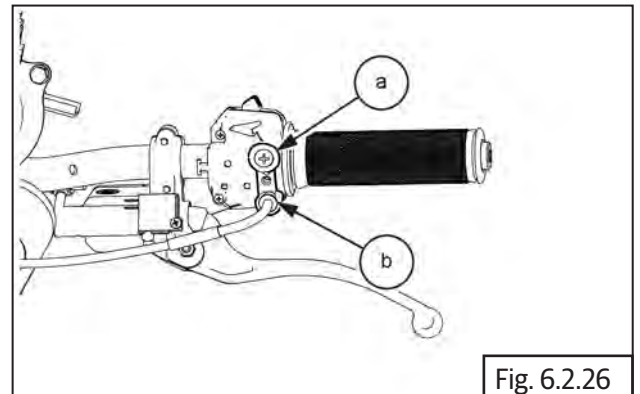

Throttle Body End

- Insert cable into the slot in the bracket in the throttle body and ensure the adjuster is fully into the bracket on throttle body.

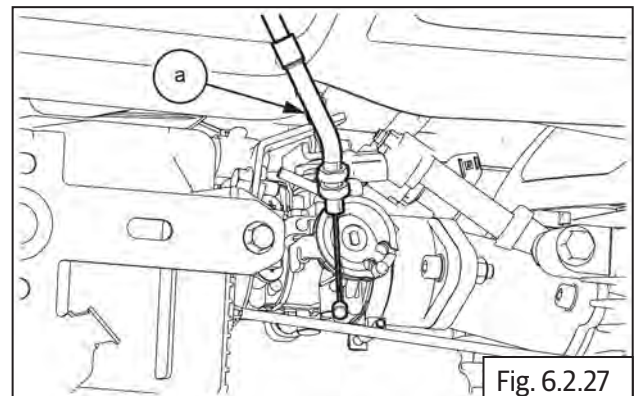

- Assemble lock nut on the inner cable.
- Position inner cable to the slot of the rotor on throttle body, insert inner cable into the eyelet and route the cable in the groove in the rotor of the throttle body.

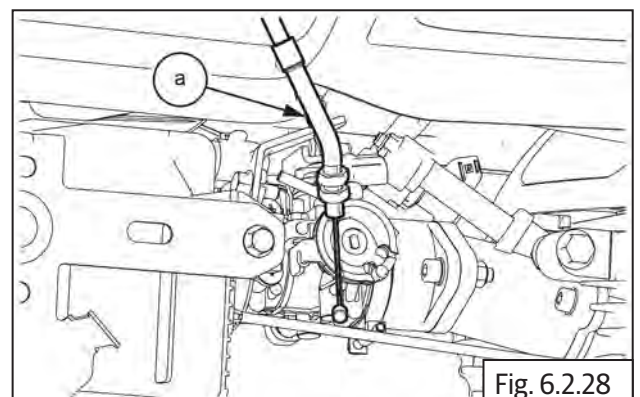

- Ensure inner cables is seated properly in the eyelets at throttle body end and handlebar end. Gently rotate throttle rotor at handlebar and ensure they are operating properly.
- Tighten the checknut **(a)** sufficiently.

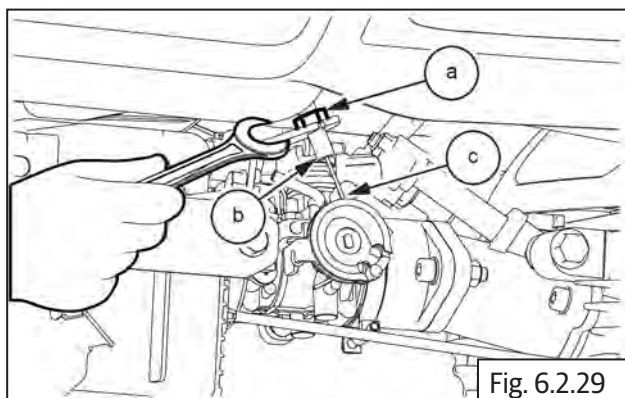

Fig. 6.2.29



12 mm Open end spanner

6.2.4. Throttle Cables Free Play Adjustment

- Gently pull adjusters out of the bracket on throttle body end till the inner cables have **NO SLACK**.
- Tighten the outside nuts on the adjusters till they are resting against the bracket on throttle body.
- Hold handlebar straight and check for free rotation of **3 to 4 mm**. (The rotor on the throttle body should not rotate).

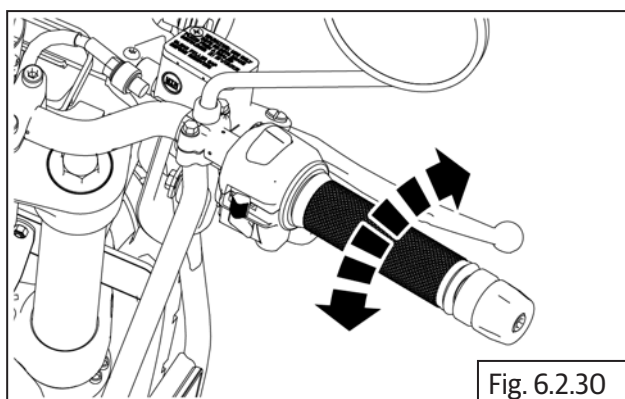

Fig. 6.2.30

- Loosen/Tighten the outer nuts to achieve the correct free play.
- Check both cables are correctly positioned and clamped to the frame, turn handlebar to both left and right sides to ensure the free play is maintained.

- Tighten inner lock nuts on the adjusters till they are firmly locked on the inside of the bracket.

NOTE

- To carry out finer adjustments to maintain the free play, turn the adjusters on the cables at the handlebar end, in or out.

- Assemble fuel tank assembly ([section 7.1.15](#)).

6.2.5. Clutch Cable

Handlebar End

- Ensure adjuster **(a)** on lever bracket LH **(b)** is in midway position and the slot in the adjuster is correctly aligned to the slot in the lever bracket LH.

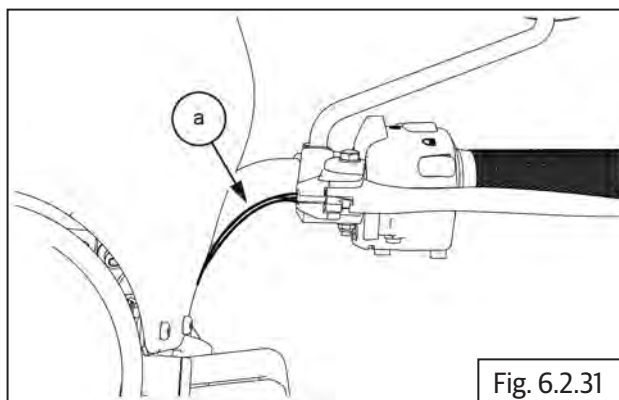

Fig. 6.2.31

- Locate inner cable into the eyelet on clutch lever and ensure it is aligned.
- Route inner cable **(a)** into the slot in the clutch bracket and adjuster and lock the outer cable into adjuster.

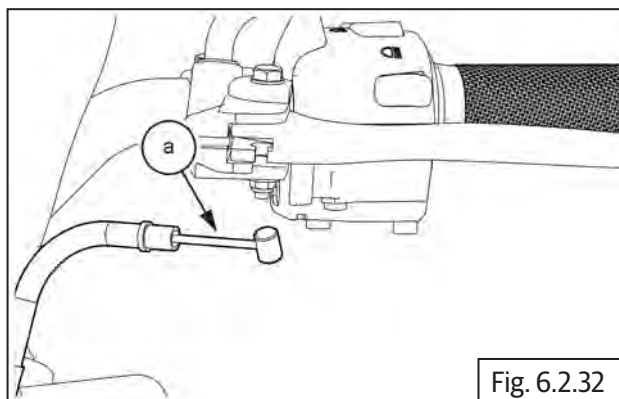

Fig. 6.2.32

- Route clutch cable between headlamp holder LH and frame towards the RH side.

Clutch cover End

- Insert inner cable into the cable guide (b) in clutch cover assembly and ensure the adjuster (a) is fully inside the guide in clutch cover assembly.

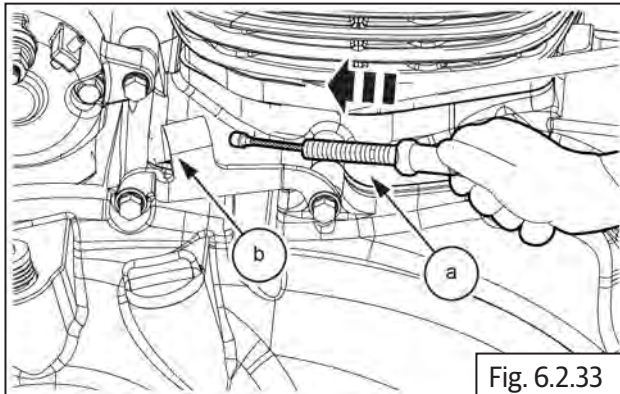

Fig. 6.2.33

- Assemble adjuster nut (a) on the adjuster and tighten by a few threads.

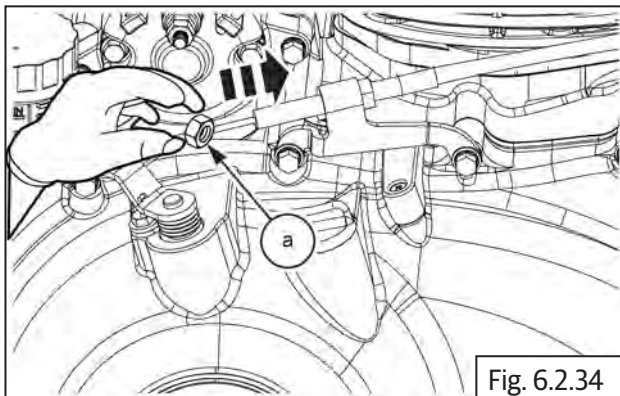

Fig. 6.2.34

- Assemble protective rubber boot (a) on clutch cable inner (b).

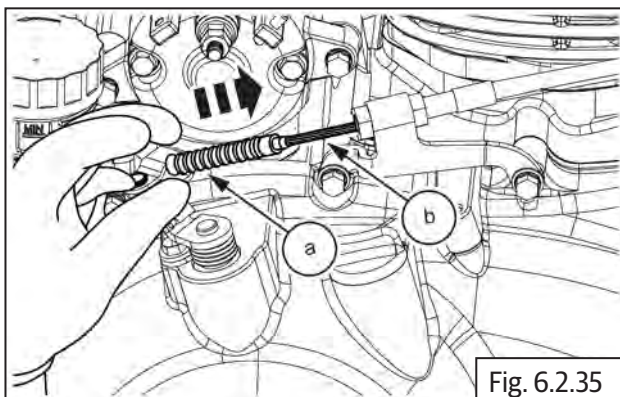

Fig. 6.2.35

- Gently locate inner cable (a) into clevis (b) in clutch actuator shaft (c).

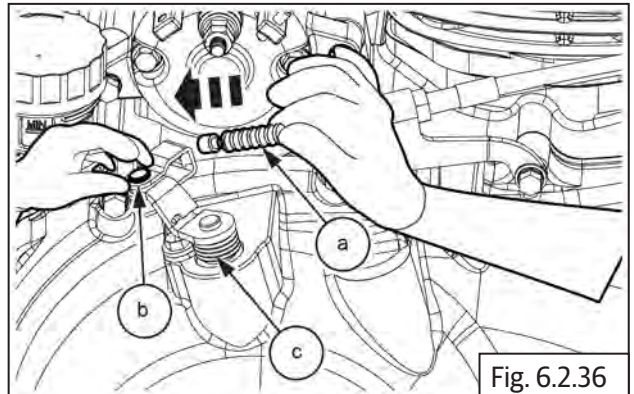

Fig. 6.2.36

Clutch Cable Free Play Adjustment

- Gently pull clutch cable adjuster (a) out of the clutch cover till the inner cable has **NO SLACK** and tighten the outer lock nut (b) against the guide in clutch cover.

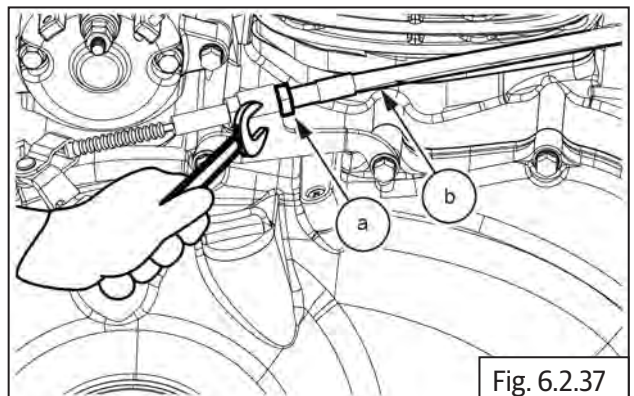

Fig. 6.2.37



12 mm Double end spanner

- Hold handlebar straight and check gap of 3-6 mm between adjuster and check nut.

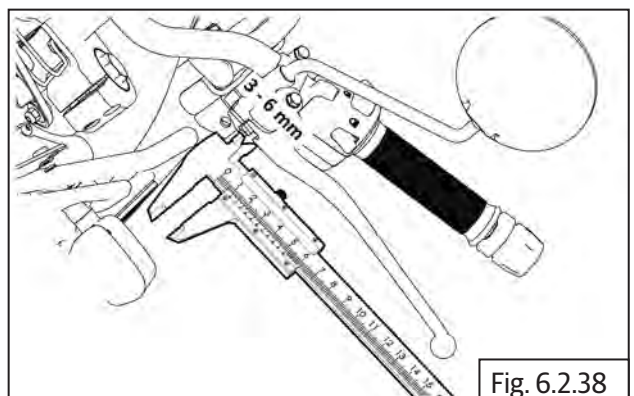
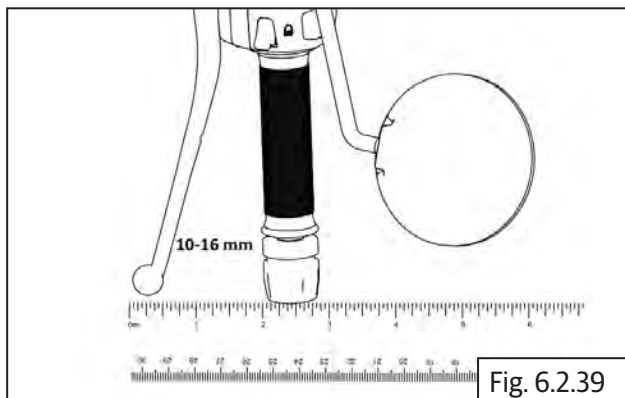
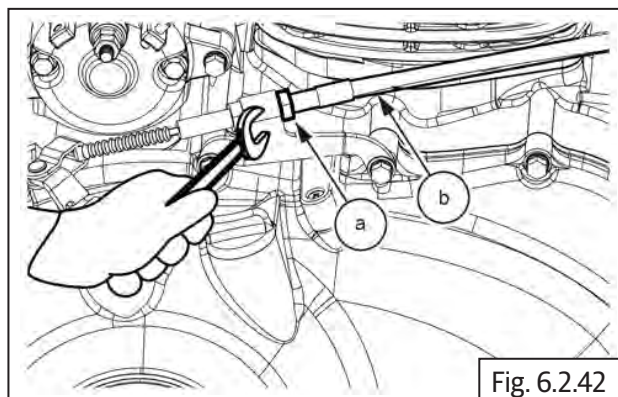

Fig. 6.2.38

- Achieve 10-16 mm of clutch play in handle bar straight position



- Torque check nuts to recommended value.



- If free play found to be out of range, adjust clutch cable at engine end.

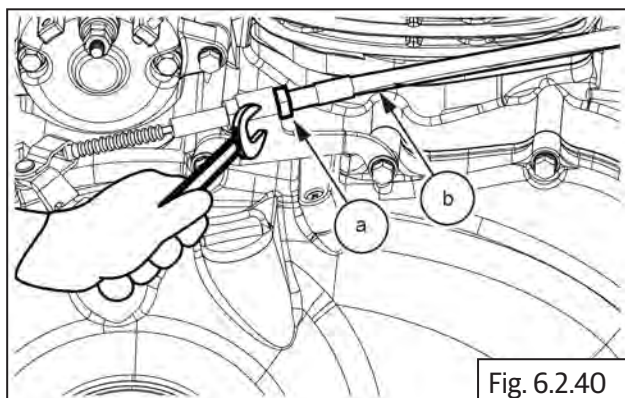

	12 mm Open End Spanner
Torque	10-12 N-m/1.0-1.2 kgf-m

- Achieve 10-12 mm of clutch play in handle bar at full left position

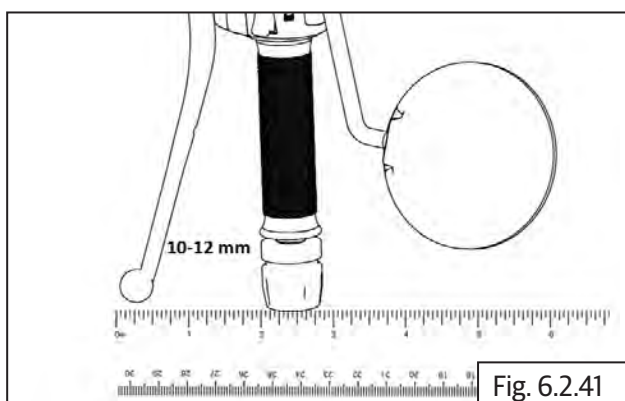

Troubleshooting

Symptom	Possible Cause	Diagnosis	How to Fix	Recommended Specification
Clutch lever movement not smooth	Clutch lever operation at handlebar end is sticky	Clutch lever, bracket and pivot screw at handlebar end is dry without lubrication/excessive dirt accumulation	Clean and lubricate clutch lever, bracket and pivot screw at handlebar end	
	Clutch lever excessive movement in handlebar bracket LH	Clutch lever mounting hole is out of shape/fixing bolt worn-out	Check and replace clutch lever bracket assembly	
	Inner cable movement sticky in outer cable	Inner cable strands broken and jammed inside outer cable/clutch lever bracket	Check and replace clutch cable	
		Teflon tube inside outer cable torn/damaged	Check and replace clutch cable	
	Clutch shaft movement sticky in cover RH	Poor/no lubrication of the clutch shaft in cover RH/uneven wear-out of clutch shaft/cover RH	Check and replace clutch shaft/cover RH	
	Clutch plates movement in clutch housing is sticky	Clutch plates/clutch housing damaged	Check and replace clutch plates/clutch assembly	
Clutch operation hard	Clutch lever movement in bracket hard	Clutch lever, bracket and pivot screw at handlebar end is dry without lubrication/excessive dirt accumulation	Clean and lubricate clutch lever, bracket and pivot screw at handlebar end	
	Inner cable movement sticky in outer cable	Inner cable strands broken and jammed inside outer cable/clutch lever bracket	Check and replace clutch cable	
		Teflon tube inside outer cable torn/damaged	Check and replace clutch cable	
	Clutch shaft movement hard in cover RH	Poor/no lubrication of the clutch shaft in cover RH/uneven wear-out of clutch shaft/cover RH	Check and replace clutch shaft/cover RH	
	Clutch plates burnt and hard	Clutch plates burnt/hard/clutch housing damaged	Check and replace clutch plates/clutch assembly	

Symptom	Possible Cause	Diagnosis	How to Fix	Recommended Specification
Throttle rotor movement sticky/ opening hard	Throttle cables are stuck between frame and fuel tank	Throttle cables stuck/ jammed between frame and fuel tank	Check cable routing and proper strapping to frame	
	Throttle rotor movement in housing is sticky	Throttle rotor area in the housing is dry/heavy dirt accumulation	Check and lubricate throttle rotor and housing in handlebar	
	Throttle rotor cable seating area damaged	The eyelets in the throttle rotor are damaged/inner cable eyelets not seating correctly in the rotor eyelets	Check and replace throttle cables/throttle rotor	
	Inner cables movement sticky in outer cable	Throttle cables inner strands broken	Check and replace throttle cables	
		Teflon coating in between inner/outer throttle cables damaged		

HANDLEBAR

CONTENTS	PAGE
6.3 Handlebar	177
Dismantling.....	177
6.3.1. Aggregates of Handlebar	177
6.3.2. Mirrors	177
6.3.3. Bar End.....	177
6.3.4. LH Switch Assembly	177
6.3.5. Clutch lever bracket	177
6.3.6. RH switch cube.....	178
6.3.7. Master cylinder.....	179
6.3.8. Handlebar	179
Assembly	180
6.3.9. Handlebar	180
6.3.10. Clutch lever bracket	180
6.3.11. LH switch cube.....	180
6.3.12. RH switchcube.....	181
6.3.13. Master Cylinder	182
6.3.14. Bar End	183
6.3.15. Mirrors	183

6.3. Handlebar Dismantling

6.3.1. Aggregates of Handlebar

Parts to be removed before dismantling

- Throttle cable
- Clutch cable
- Brake master cylinder
- Electrical connectors of LH and RH switch cubes
- Cable routing straps

6.3.2. Mirrors

- Loosen hex nut **(a)** and rotate rear view mirror LH in clockwise direction.

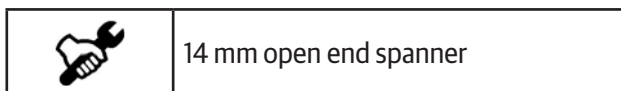
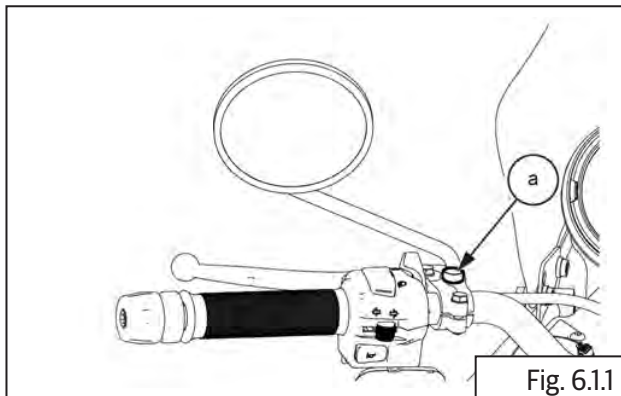

- Loosen hex nut **(a)** and rotate rear view mirror RH in anticlockwise direction.

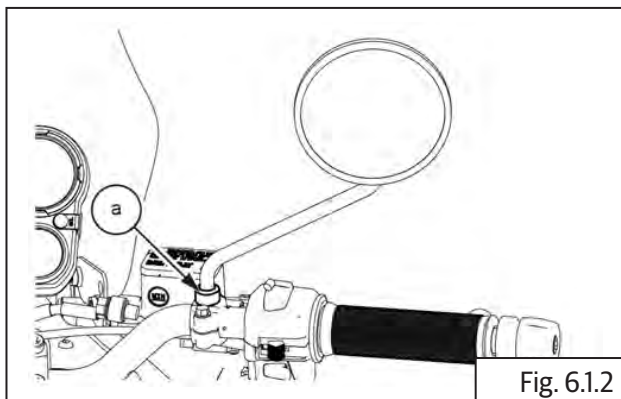

6.3.3. Bar End

- Loosen and remove allen bolt **(M6)** **(a)** along with bar end **(b)** from LH and RH of the handlebar

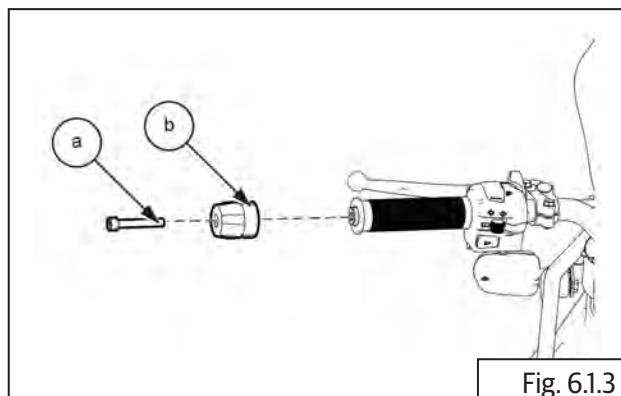

6.3.4. LH Switch Assembly

- Disconnect the clutch switch

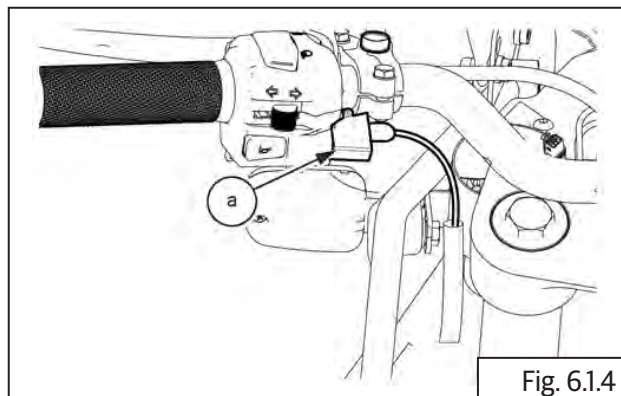

6.3.5. Clutch lever bracket

- Wrap a cloth soaked in hot water on LH grip **(a)** and allow the grip to become free on the handle bar. Rotate the grip and pull it outwards to remove from handlebar.

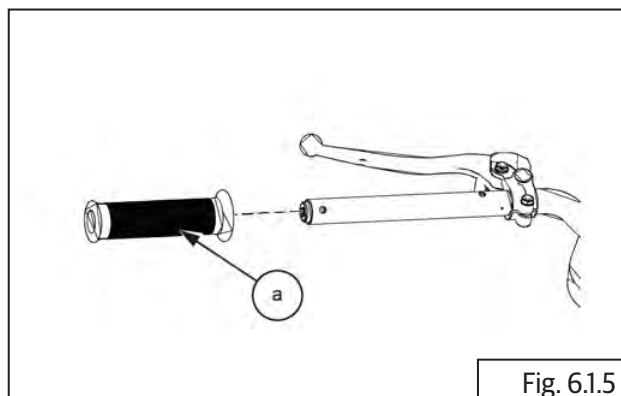

- Loosen and remove 1 Nos hex socket bolts (**M6**) (**a**) to remove the clutch lever bracket along with the lever.

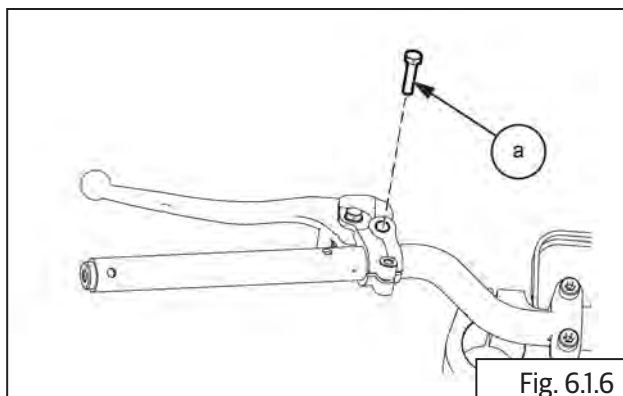

- Remove clutch lever bracket (**a**)

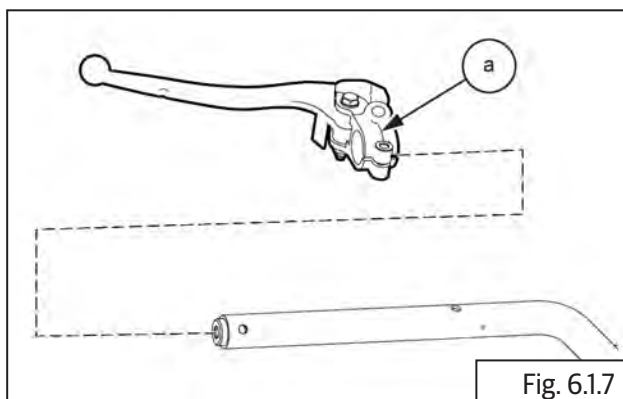

6.3.6. RH switch cube

- Remove throttle cable guide plate (**a**) from switch cube lower bracket (**b**).

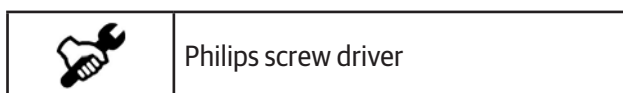
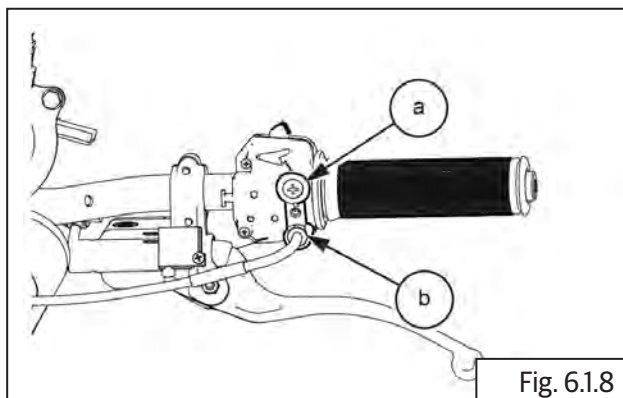

- Remove 2 nos. Philips head screws from the RH switch cube from handle bar.

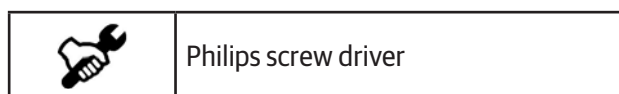
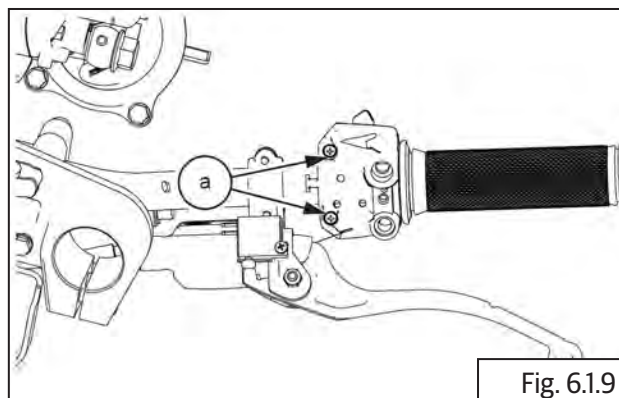

- Gently separate the top (**a**) and bottom (**b**) of the module to remove from handlebar RH.

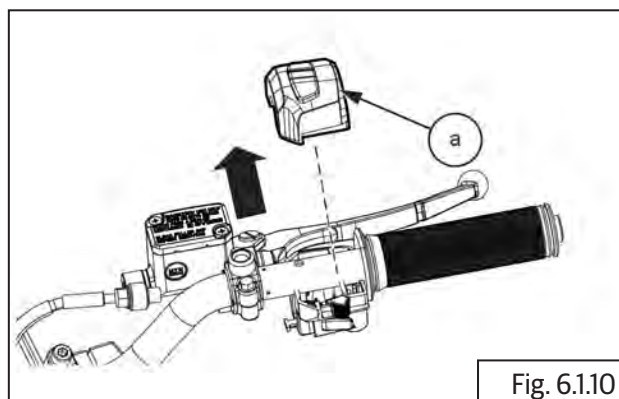

- Disconnect the throttle cable (**a**) from the throttle grip (**b**).

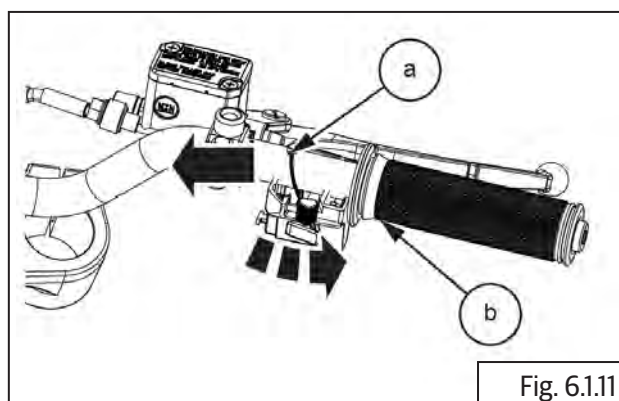

- Remove throttle grip **(a)** from the handlebar **(b)**.

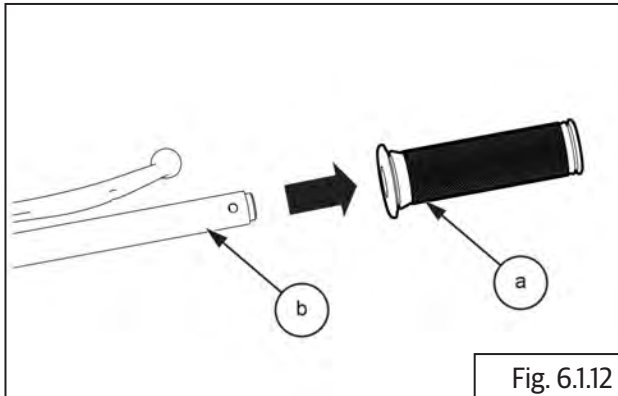

Fig. 6.112

- Remove 2 nos clamps from the handlebar.

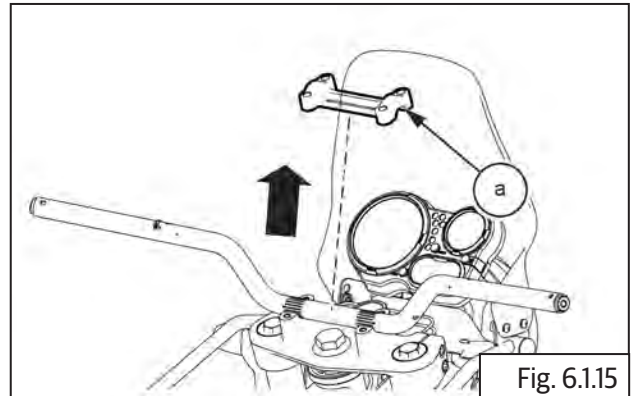

Fig. 6.115

6.3.7. Master cylinder

- Remove 2 nos hex socket bolt **(M6) (a)** from the master cylinder assembly to remove from the handlebar.

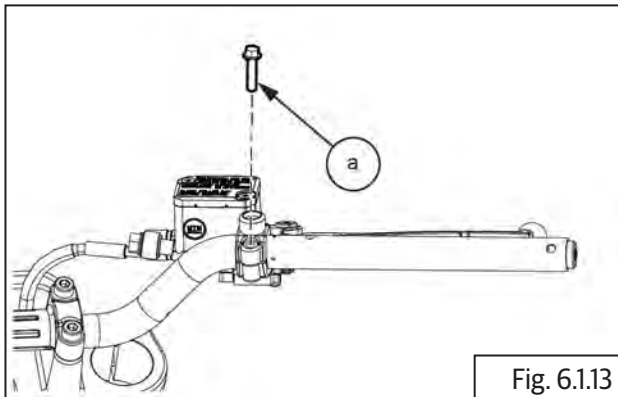

Fig. 6.113



10 mm Socket with Ratchet

- Remove the handlebar **(a)**.

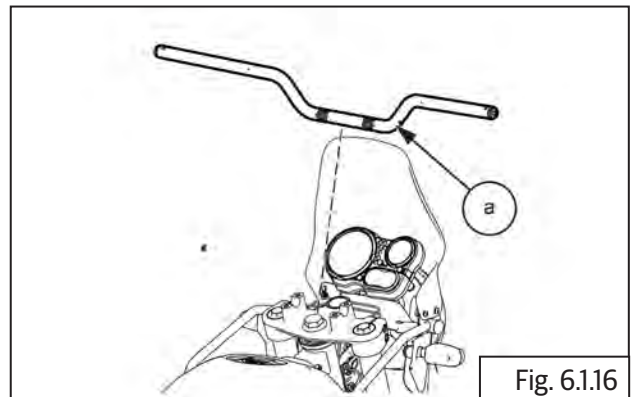

Fig. 6.116

6.3.8. Handlebar

- Loosen and remove 4 nos allen bolts **(M8) (a)** from top clamps.

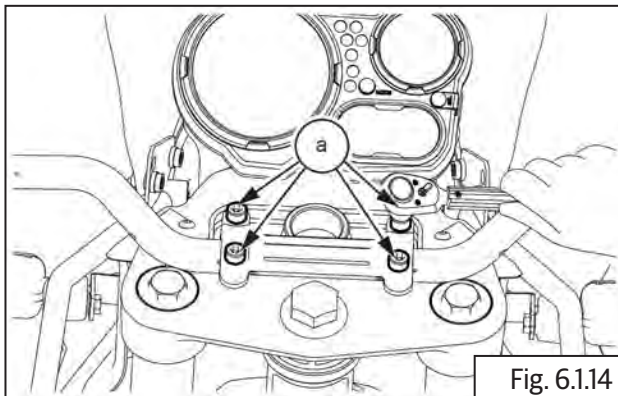

Fig. 6.114



6 mm allen key

Assembly

6.3.9. Handlebar

- Locate the handlebar **(a)** on the handlebar raiser

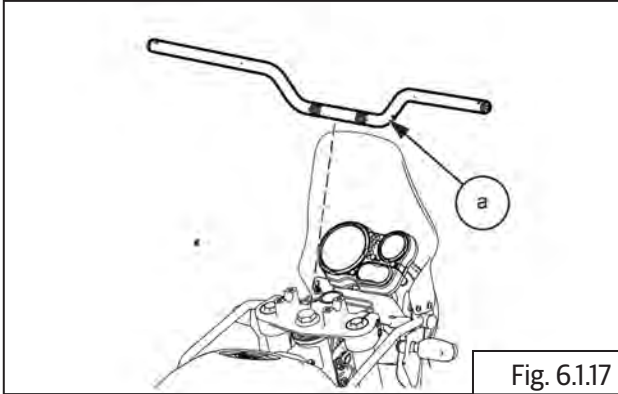

- Install top clamp over the handlebar.

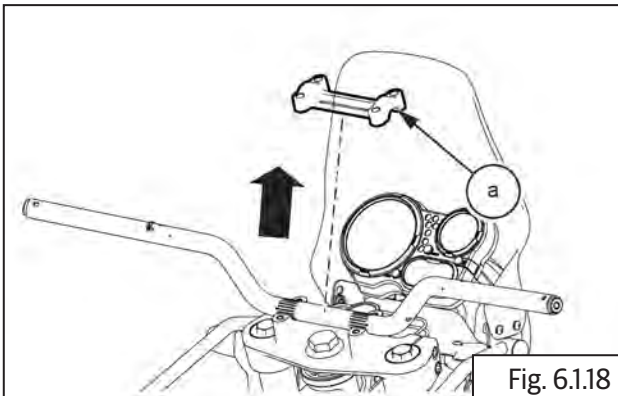

- Locate and tighten 4 nos allen bolts **(M8) (a)** into the handlebar clamps.

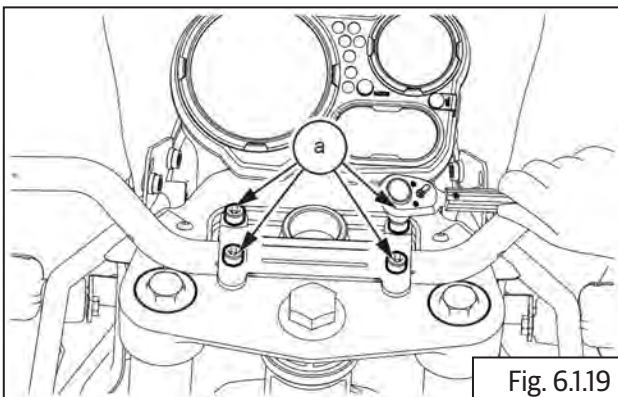

	6 mm Allen Socket with Torque wrench
Torque	24-28 N-m/2.4-2.8 kgf-m

6.3.10. Clutch lever bracket

- Position the clutch lever bracket past the hole present in the handlebar.

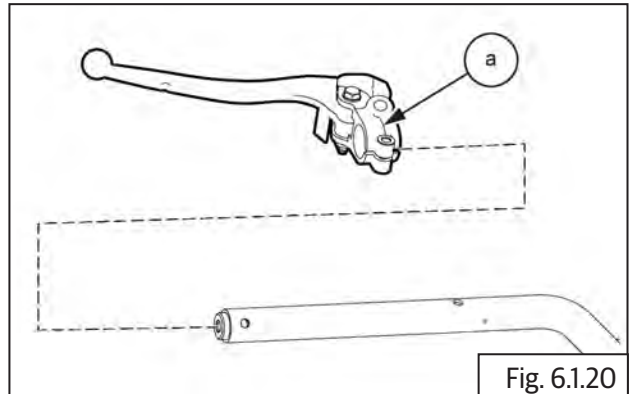

- Locate and tighten 1 no hex soc bolt **(M6) (a)**

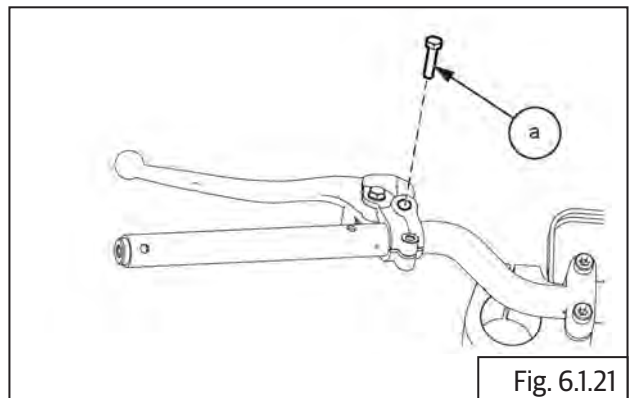

	10 mm Socket with Torque wrench
Torque	10-12 N-m/1.0-1.2 kgf-m

6.3.11. LH switch cube

- Locate the switch module on the LH of the handlebar.
- Ensure the peg **(a)** in the module is inserted in the hole provided in the handlebar.

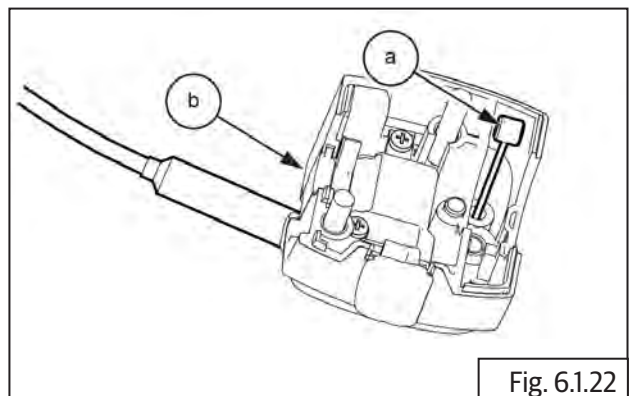

- Assemble the top and bottom modules.

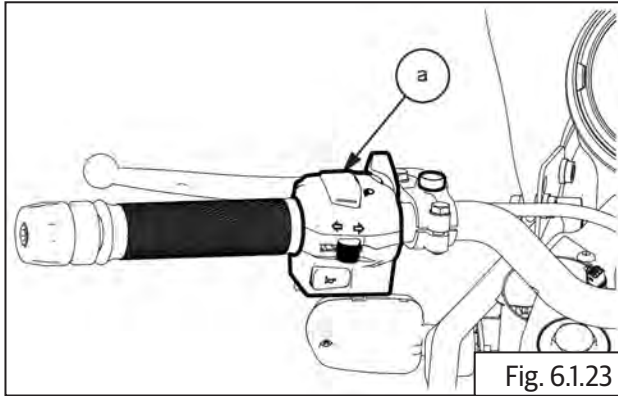

- Insert 2 Nos Philips head screws and tighten

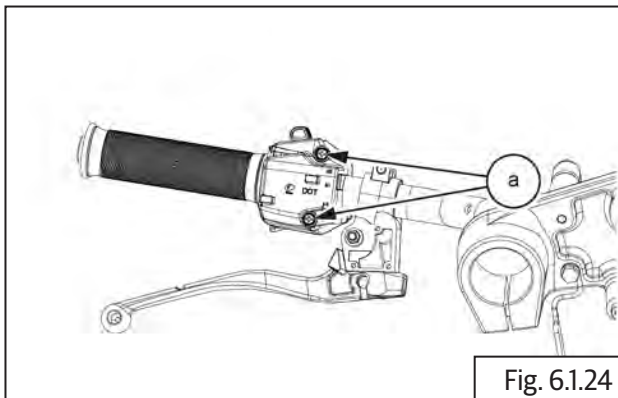

- Connect the clutch switch wires.

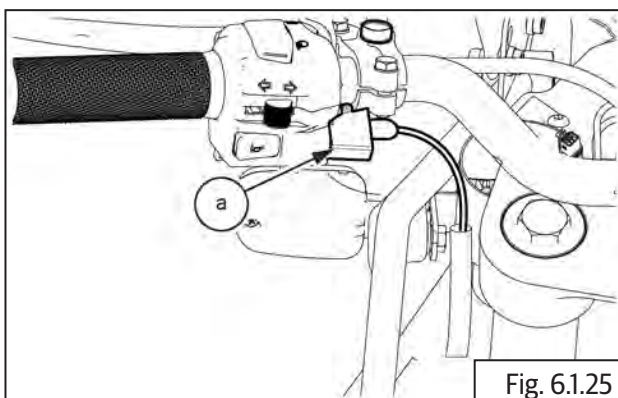

- Soak grip into hot water before assembling.
- Assemble the grip and let it rest till it is fixed on the handlebar.

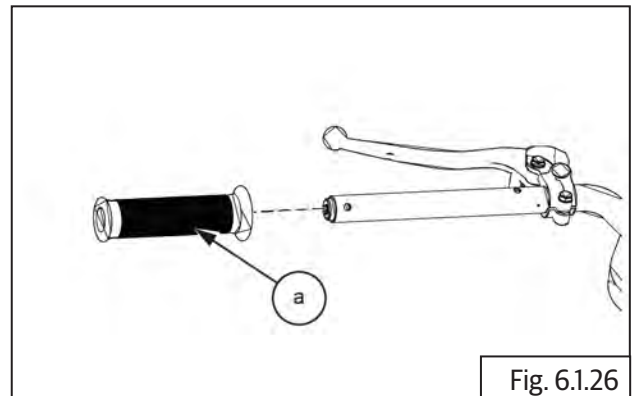

6.3.12. RH switchcube

- Lubricate the throttle grip with general purpose grease and assemble on handlebar RH.

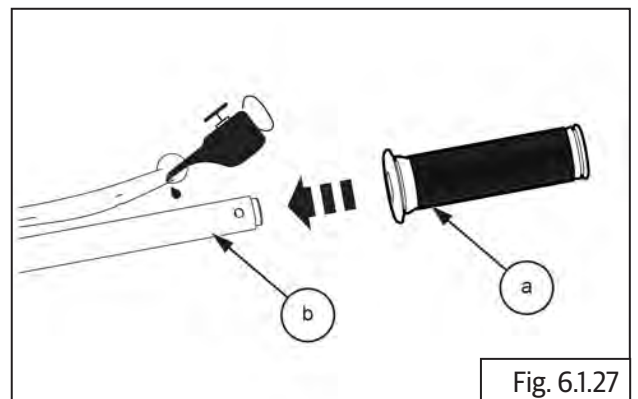

- Insert throttle cable (a) into the bottom housing (b) of the switch cube and connect it to the throttle grip.

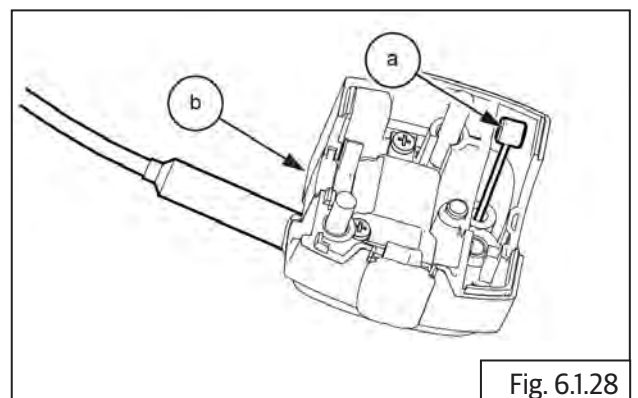

- Assemble switch mounting top **(a)** and bottom **(b)** are on handlebar.

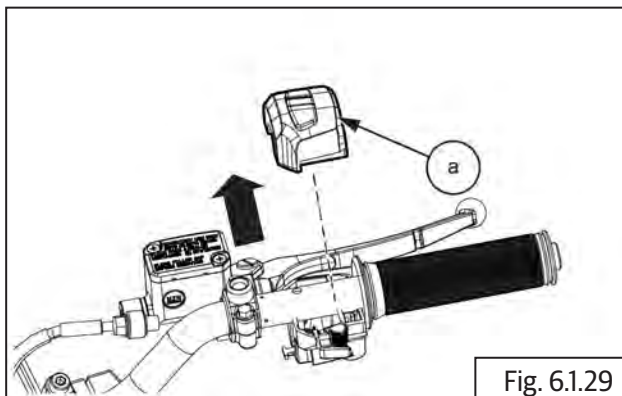

- Insert Philips head screw **(a)** and tighten sufficiently.

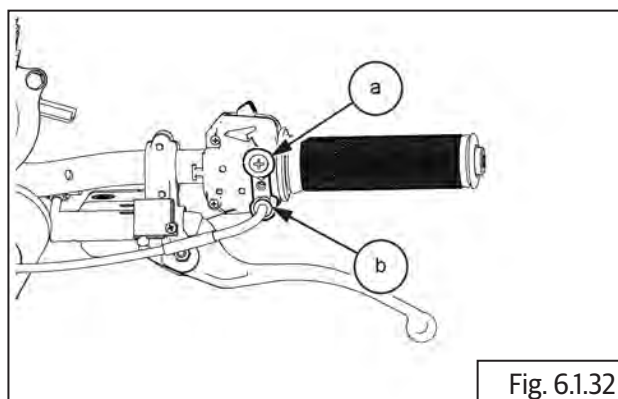

6.3.13. Master Cylinder

- Insert 2 Nos Philips head screws **(a)** and **(b)** on the switch cube and tighten.

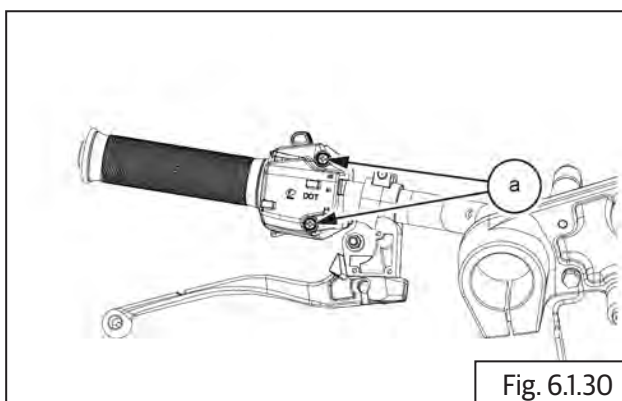

- Locate the master cylinder bracket against the switch module RH, ensure the lever is slightly lower than the throttle grip.

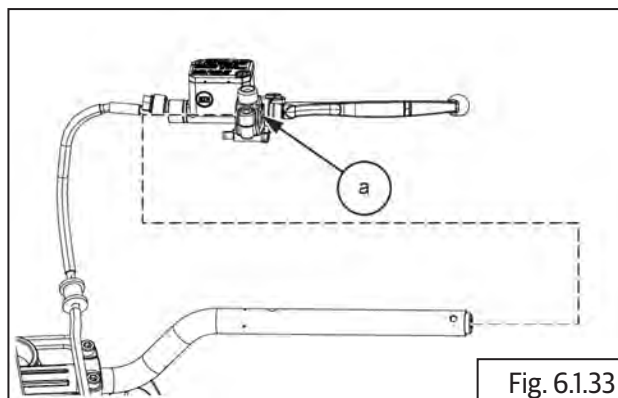

- Install the brake light switch **(a)** on the switch cube with 2 Nos Philips head screws.

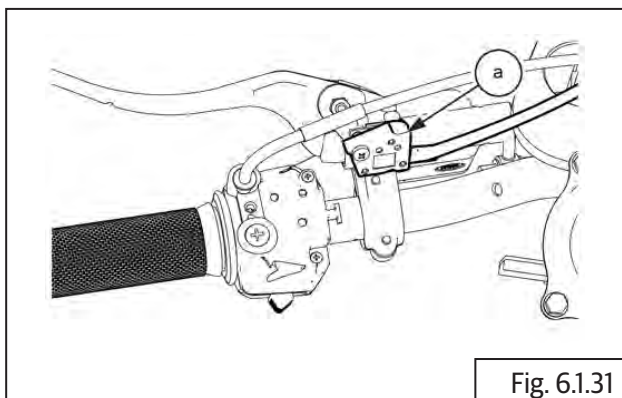

- Locate clamp on the handlebar RH and tighten 2 nos hex head bolts **(M5)**.

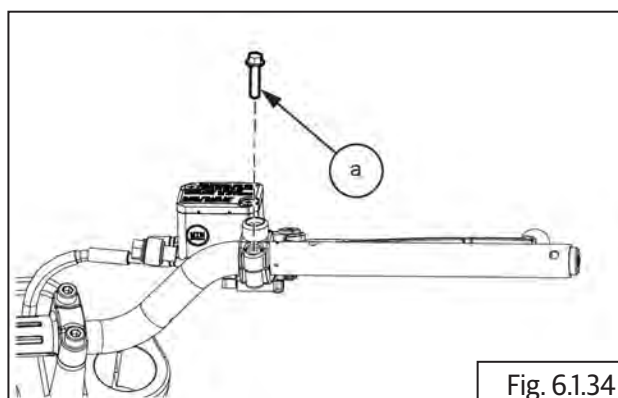

6.3.14. Bar End

- Insert and tighten allen bolt **(a)** along with the bar end **(b)** on both sides of the handlebar.

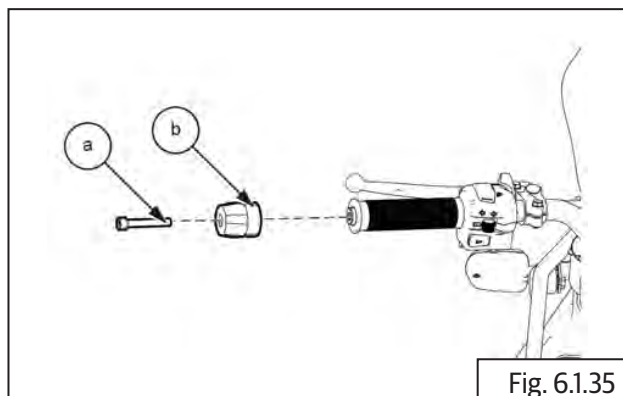

6.3.15. Mirrors

Right Hand Side

- Ensure locknut on RH mirror is fully tighten.

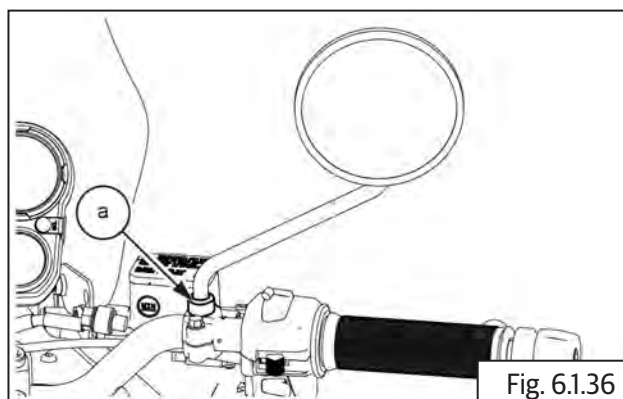

- Locate the thread portion of rear view mirror stem on master cylinder bracket. Rotate clockwise till the mirror comes to a stop.

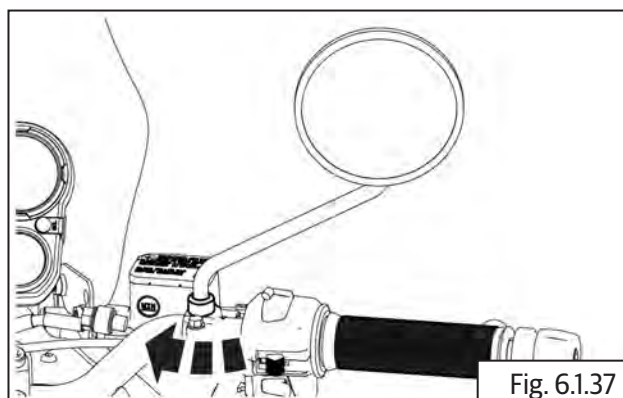

- Rotate mirror clockwise for adjusting the view and tighten locknut against bracket.

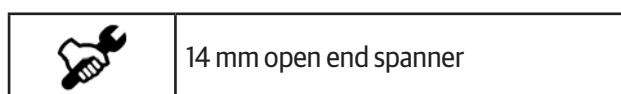
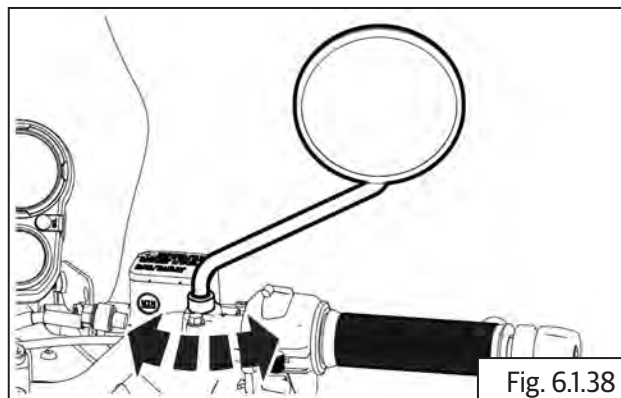

Left Hand Side

- Ensure locknut on LH mirror is fully tighten.

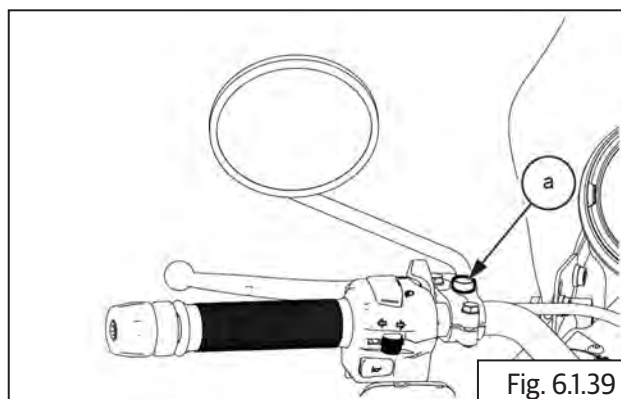

- Locate the thread portion of rear view mirror stem on clutch lever bracket. Rotate anti clockwise till the mirror comes to a stop.

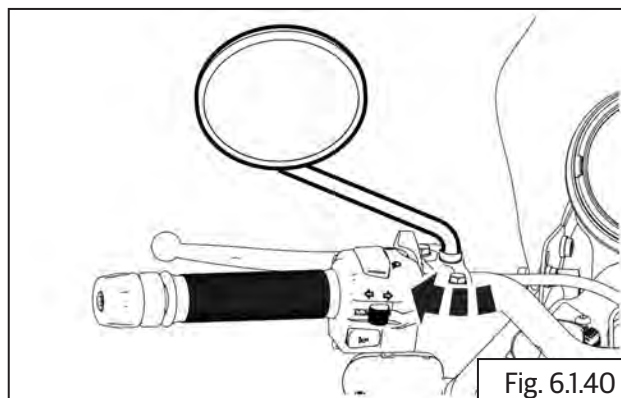

- Rotate mirror clockwise for adjusting the view and tighten locknut against bracket.

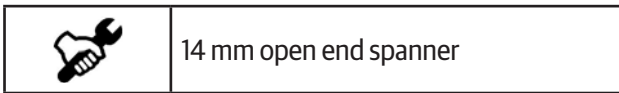
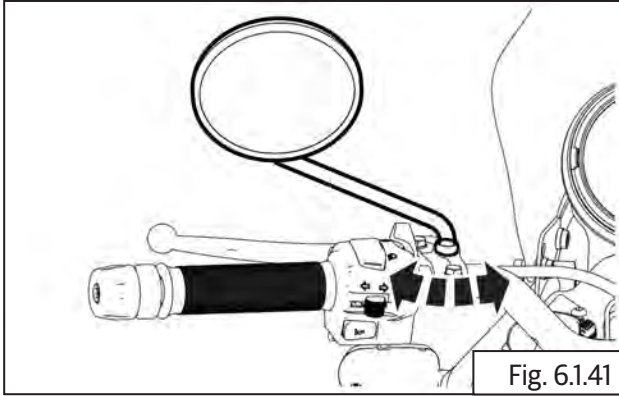

EXHAUST PIPE, SILENCER AND CATALYTIC CONVERTER

Exhaust Pipe, Silencer and Catalytic Converter

CONTENTS	PAGE
6.4 Exhaust Pipe, silencer.....	187
Dismantling.....	187
6.4.1. Silencer.....	187
6.4.2. Exhaust Header Pipe	188
6.4.3. O2 Sensor	188
Assembly	188
6.4.4. O2 Sensor	188
6.4.5. Exhaust Header Pipe	189
6.4.6. Silencer	189

6.4. Exhaust Pipe, silencer and catalytic converter.

Dismantling

⚠ CAUTION

DO NOT perform any operation on exhaust pipe, silencer and catalytic converter soon after the engine is turned OFF. The exhaust components will be extremely hot and can cause serious injuries and burns.

6.4.1. Silencer

- Loosen and remove 3 Nos. hex socket bolts (**M6**) (**a**) from the silencer guard at muffler end.

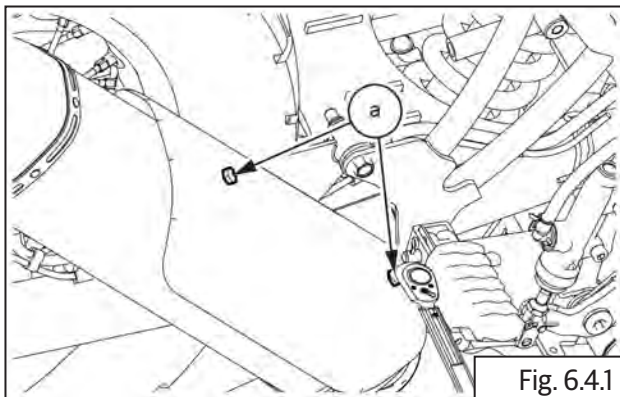

10 mm socket with ratchet

- Remove silencer guard (**a**) along with bolts (**b**).

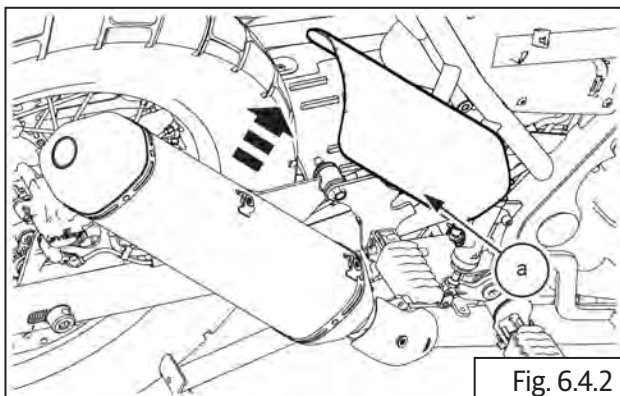

- Remove 2 nos hex socket bolts (M6) from silencer guard at the header pipe end.

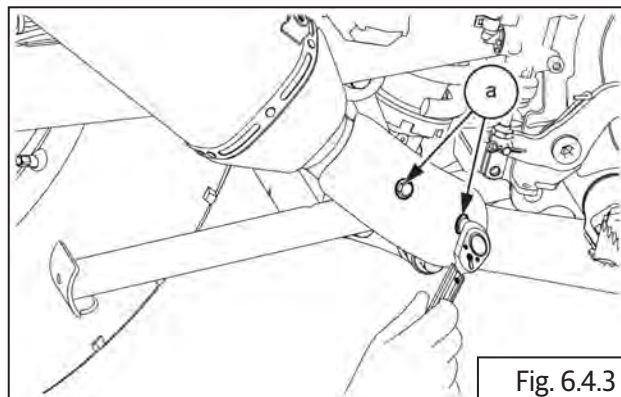

10 mm socket with ratchet

- Remove the silencer guard (**a**).

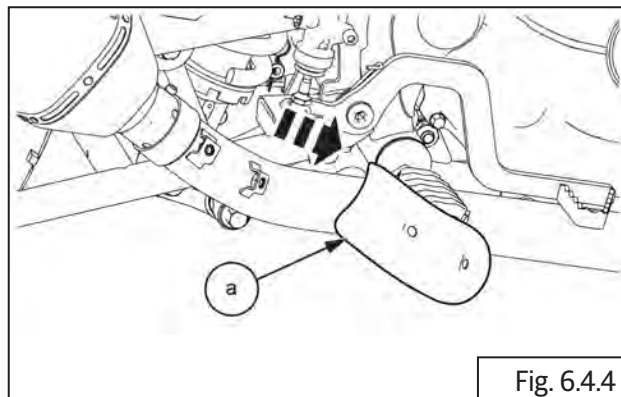

- Remove the header pipe mounting nut (**a**).

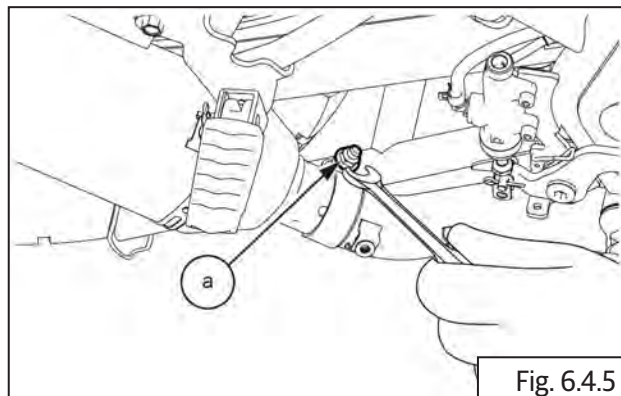

12 mm socket with ratchet

- Remove silencer mounting bolt **(a)** and from frame.

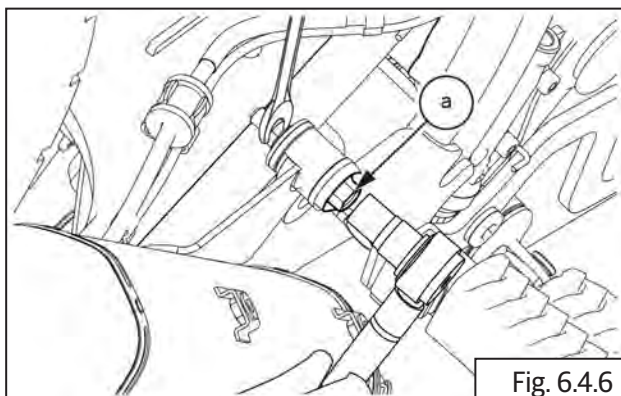

Fig. 6.4.6



12 mm socket with ratchet

- Gently pull the silencer outwards to remove.

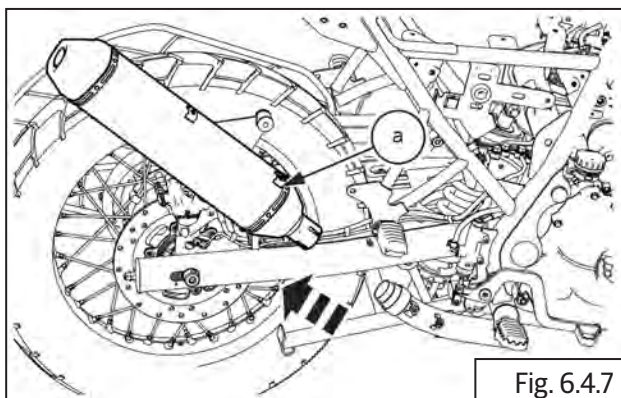

Fig. 6.4.7

6.4.2. Exhaust Header Pipe

- Remove 2 nos 14 mm nuts **(a)** from the cylinder head assembly.

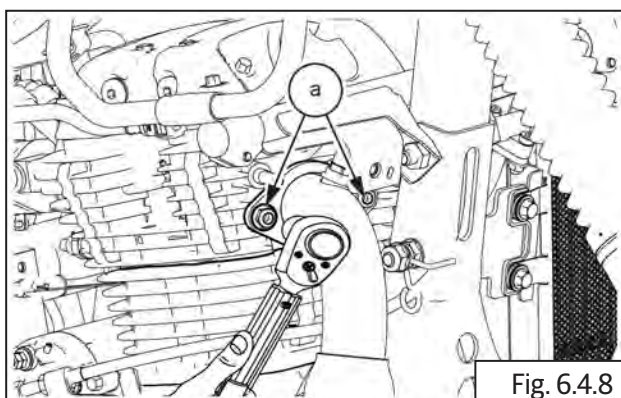

Fig. 6.4.8



14 mm socket with ratchet

- Remove the exhaust header pipe along with 2 nos mounting fins.

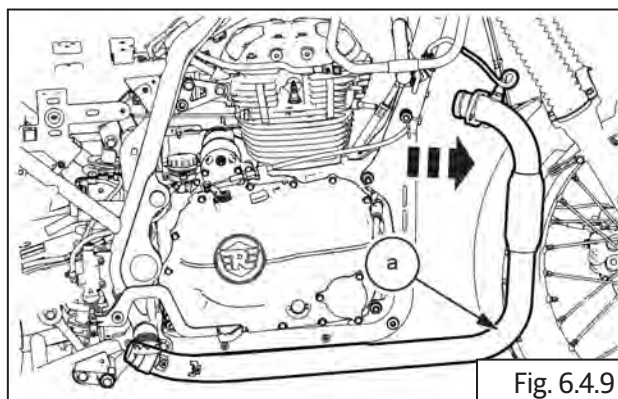

Fig. 6.4.9

6.4.3. O2 Sensor

- Refer headlamp dismantling section to remove O2 sensor socket.
- Loosen and remove O2 sensor **(a)** from the header pipe.

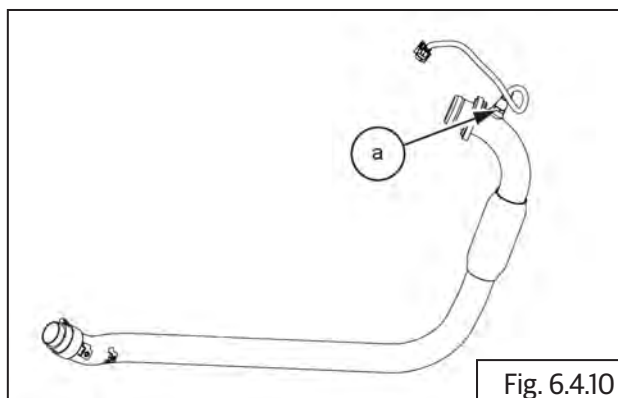

Fig. 6.4.10





17 mm open end spanner

Assembly

6.4.4. O2 Sensor

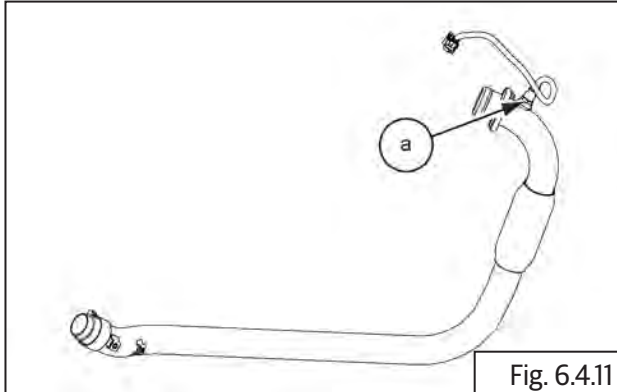
- Locate and tighten O2 sensor on the exhaust header pipe.



	17 mm socket with Ratchet
Torque	15-20 N-m/1.5-2.0 kgf-m

6.4.5. Exhaust Header Pipe

- Locate exhaust pipe **(a)** into exhaust manifold on the cylinder head and ensure the exhaust pipe flange **(b)** is properly located on the studs **(c)**.

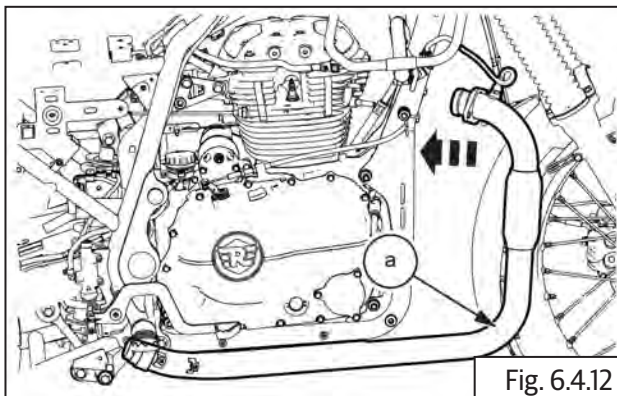

- Assemble 2 nos hex nuts on the studs and hand tight it to align the rear end mounting.

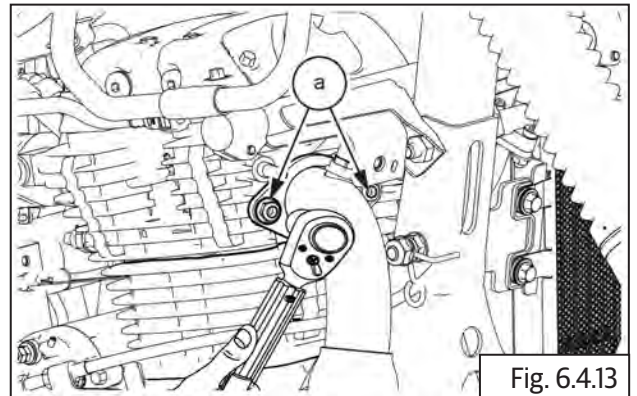

	14 mm socket with ratchet
--	---------------------------

6.4.6. Silencer

- Insert the silencer **(a)** in the header pipe.

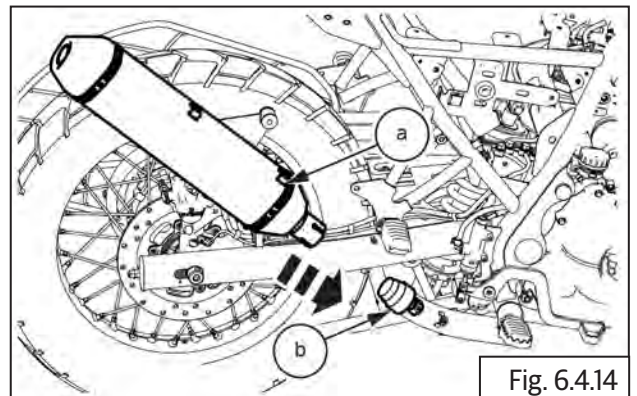

- Locate the mounting hole in the frame and insert **(M8)** bolt and tighten it.

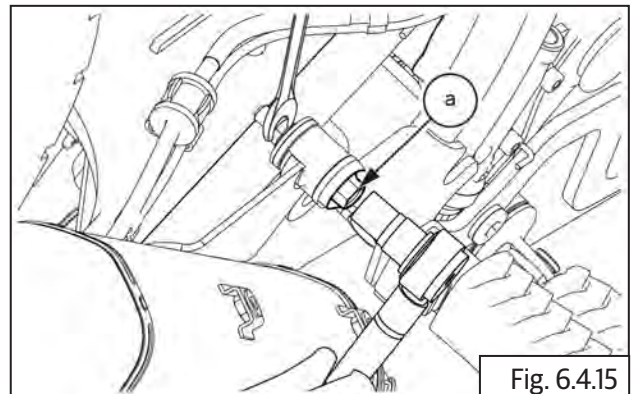

	12 mm socket with ratchet
Torque	21-29 N-m/2.1-29 kgf-m

- Tighten the mounting clamp **(a)** at the header pipe end.

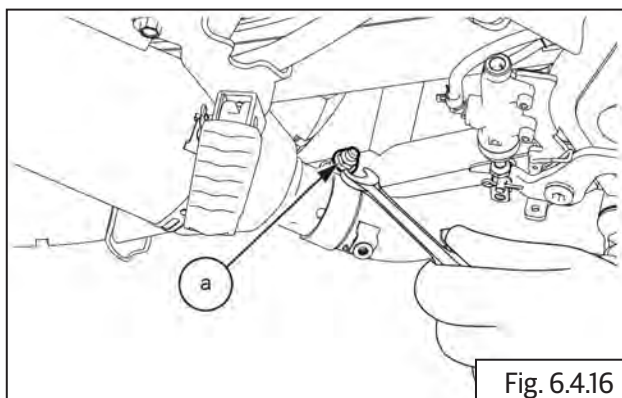



Fig. 6.4.16

	12 mm socket with ratchet
Torque	20-25 N-m/2.0-2.5 kgf-m

- Locate the silencer guard front plate and fix it on the silencer with 2 nos **(M6)** hex socket bolts.

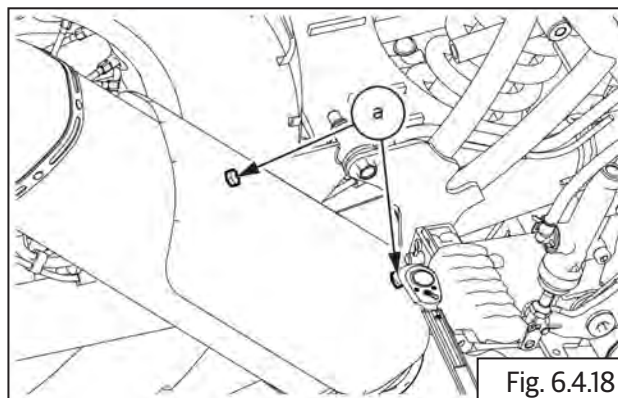



Fig. 6.4.18

	10 mm socket with ratchet
Torque	10-12 N-m/1.0-1.2 kgf-m

- Locate the silencer guard back plate and fix it in the silencer with 2 Nos **(M6)** hex socket bolts..

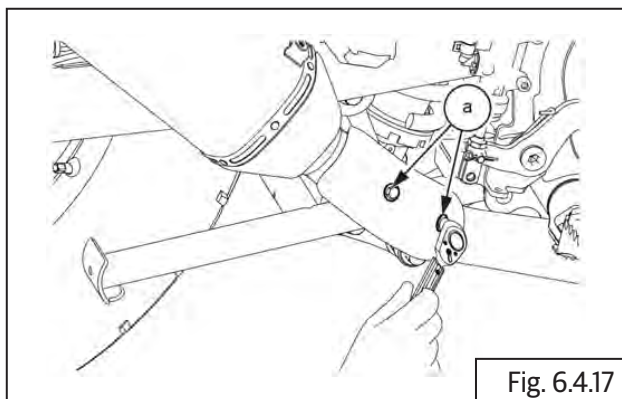



Fig. 6.4.17

	10 mm socket with ratchet
Torque	10-12 N-m/1.0-1.2 kgf-m

FOOTRESTS, STANDS AND SAREE GUARD FOOTREST DISMANTLING

Footrests, Stands and Saree Guard Footrest Dismantling

CONTENTS	PAGE
6.5 Footrests, Stands and Saree Guard Footrest	193
Dismantling.....	193
6.5.1. Rider LH and RH	193
6.5.2. Pillion LH and RH	193
6.5.3. Side Stand	194
6.5.4. Saree guard (For Indian market only).....	195
Assembly	195
6.5.5. Rider LH and RH.....	195
6.5.6. Pillion LH and RH	196
6.5.7. Side Stand	196
6.5.8. Saree guard (For Indian market only).....	197

6.5. Footrests, Stands and Saree Guard Footrest Dismantling

6.5.1. Rider LH and RH

- Remove the cotter pin **(a)** at the bottom of the footrest.

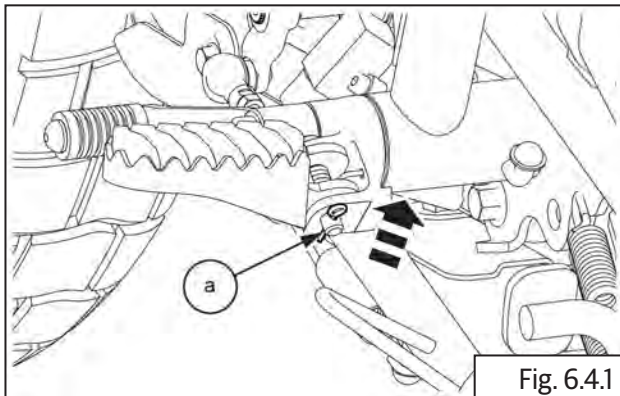

- Push the pin **(a)** on the upward direction.

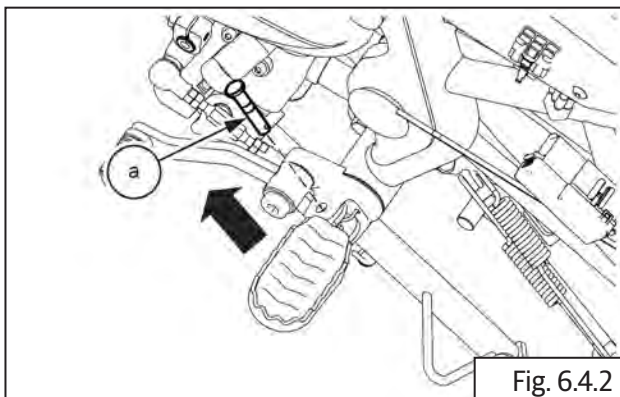

- Remove the footrest along **(b)** with ball and spring **(a)**.

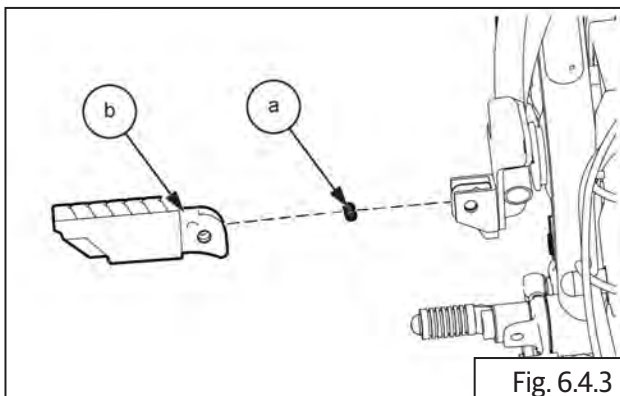

6.5.2. Pillion LH and RH

- Remove cotter pin **(a)** from the bottom of the footrest.

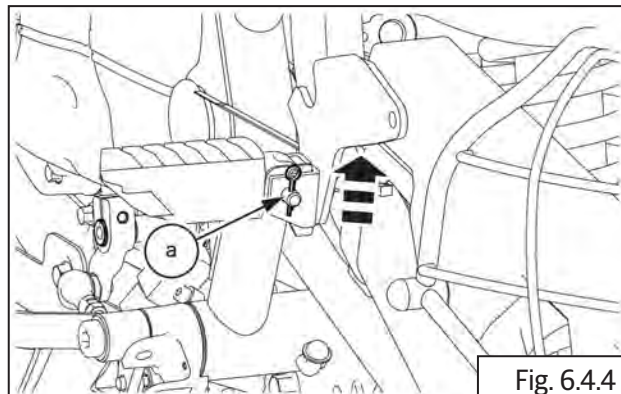

- Gently pull out pin **(a)** from the top supporting the footrest.

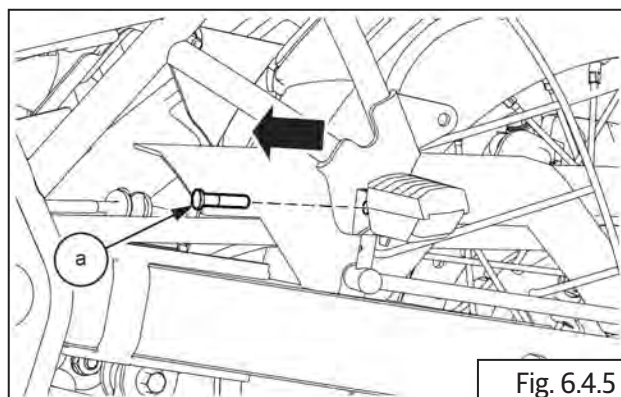

- Remove footrest **(b)** from mounting bracket carefully along with ball and spring **(a)**.

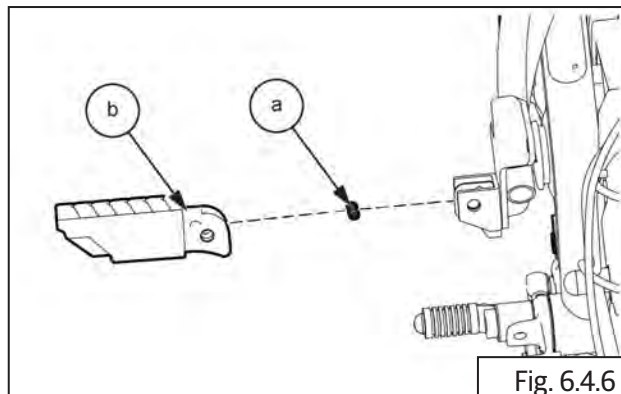

Side Stand Dismantling

6.5.3. Side Stand

- Ensure the vehicle is on the main stand and is placed in a firm and flat surface.
- Loosen and remove 2 Nos. **M6** bolt (a) from the side stand switch.

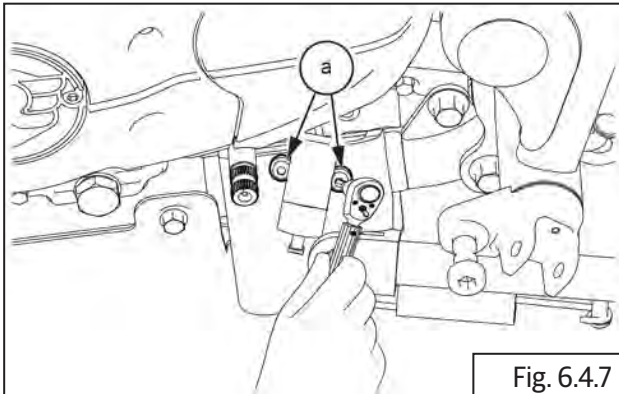

12 mm Socket with Ratchet

- Remove side stand switch (a).

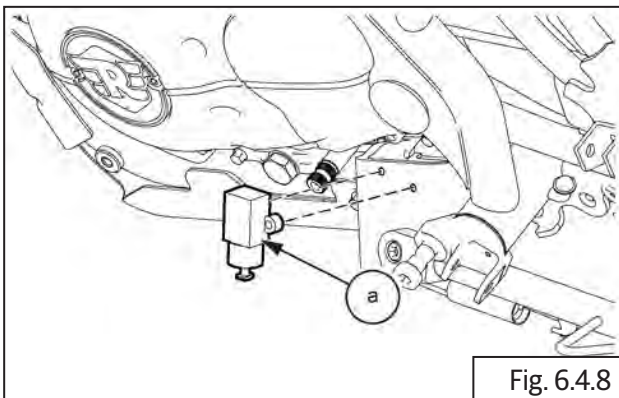

- Remove spring (a) from the side stand.

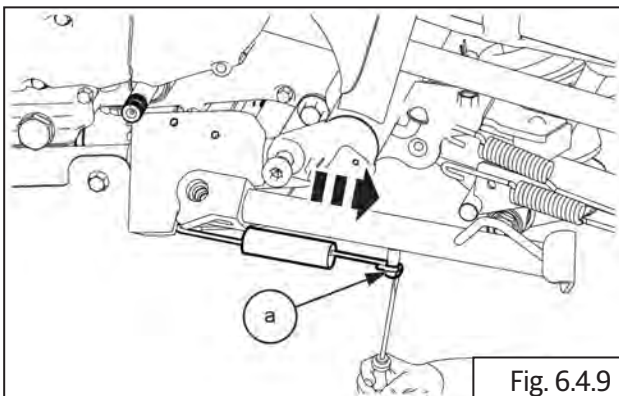

Screw driver

- Remove the hex nut (a) from the back side of the stand.

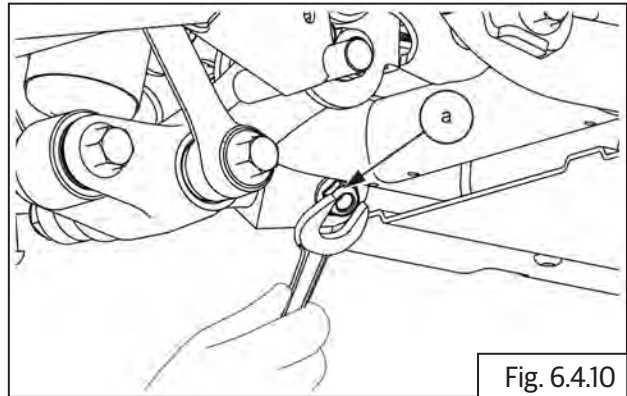

12 mm Socket with Ratchet

- Gently pull the bolt (a) to remove.

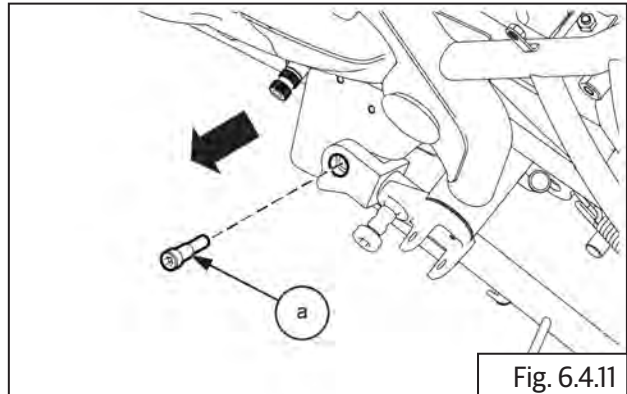

- Remove the stand (a).

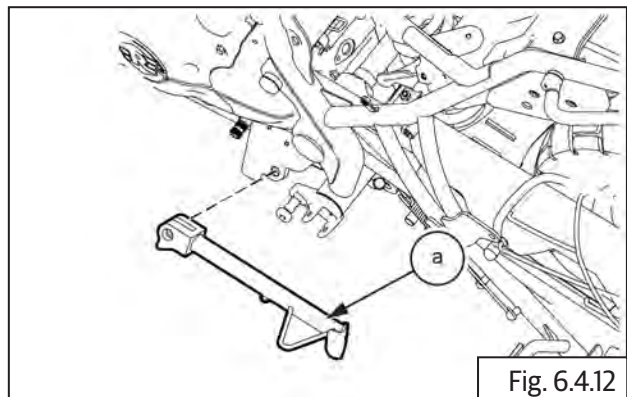

Saree Guard Dismantling

6.5.4. Saree guard (For Indian market only)

- Remove 3 Nos. **M8** bolt (**a**) from LH frame.

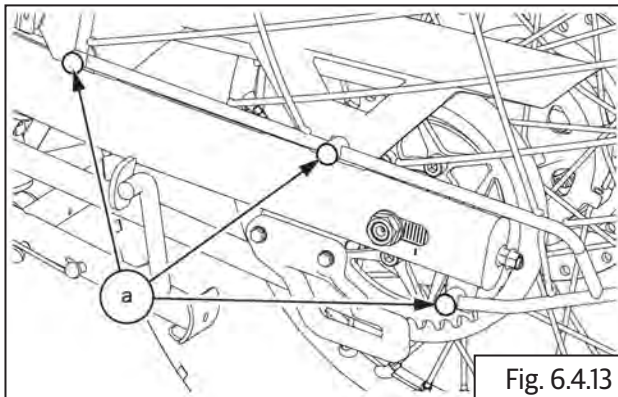

12 mm socket with ratchet

- Remove the saree guard (**a**).

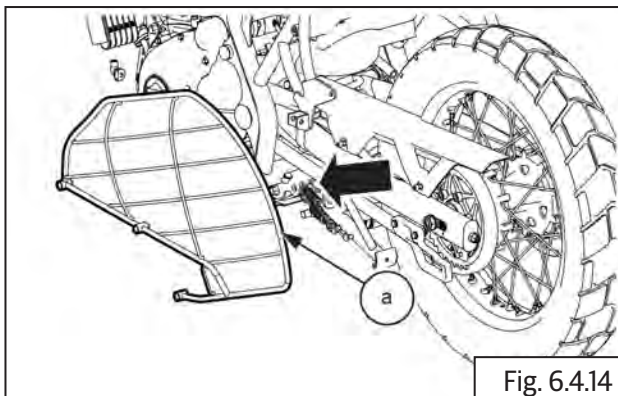

Footrest Assembly

6.5.5. Rider LH and RH

- Locate the spring (**a**) between the footrest (**b**) on the mounting bracket.

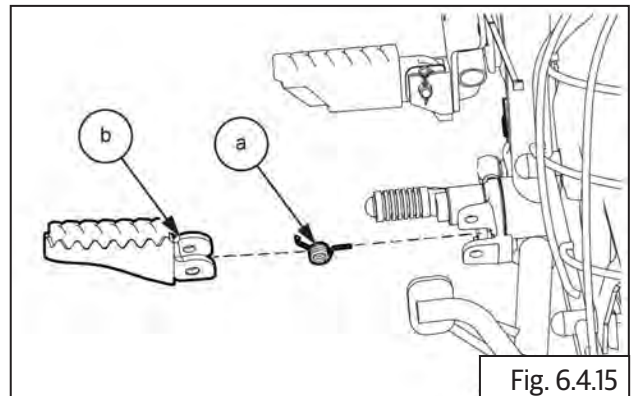

- Insert the pin (**a**) along with washer.

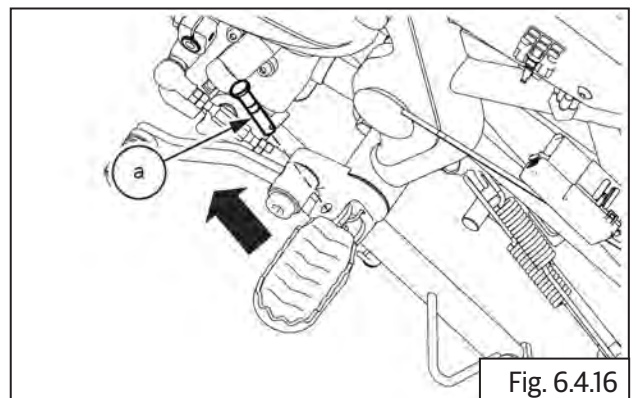

- Install the cotter pin (**a**) at the bottom of the pin.

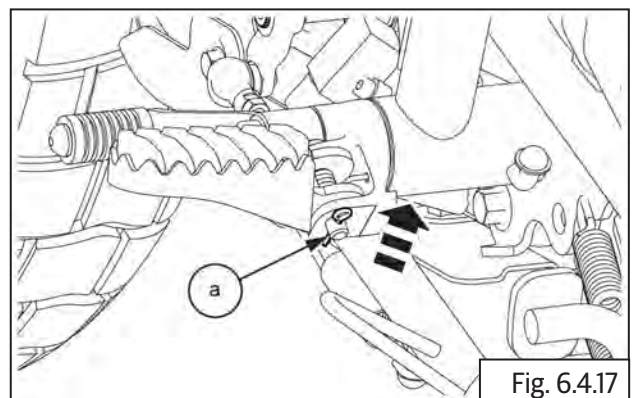

Nose Plier

6.5.6. Pillion LH and RH

- Install spring **(a)** in the groove provided **(b)**.

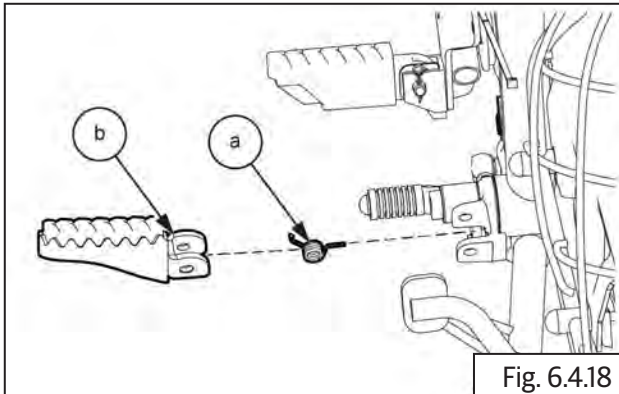

- Install pin **(a)** along with washer.

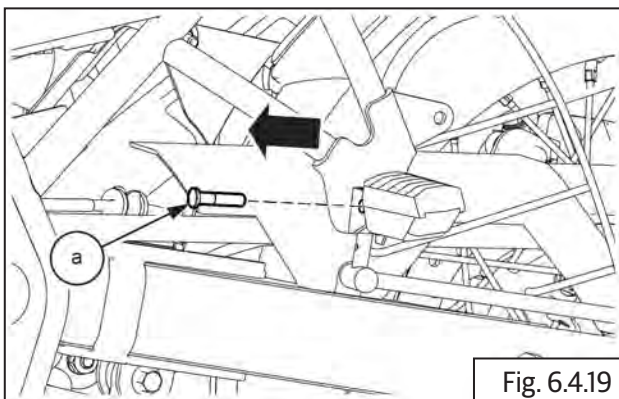

- Install the cotter pin **(a)** at the bottom of the pin.

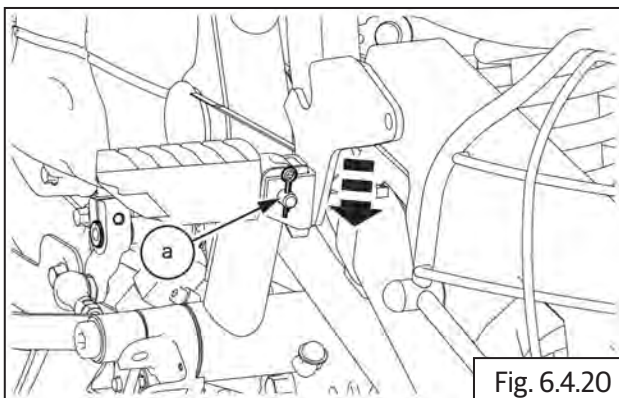

Nose Plier

Side Stand Assembly

6.5.7. Side Stand

- Apply grease on the inner surface of the stand **(a)**.

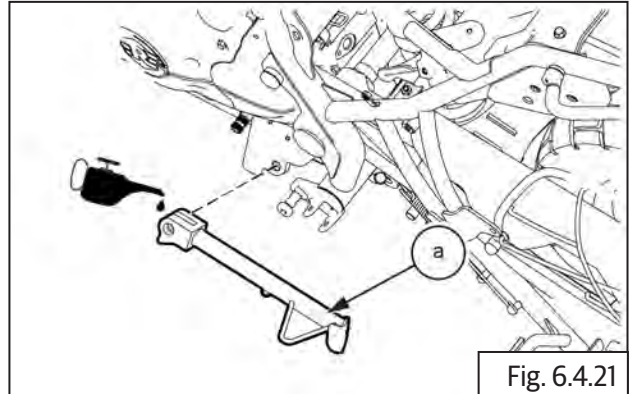

- Locate the stand **(a)** in the frame **(b)**.

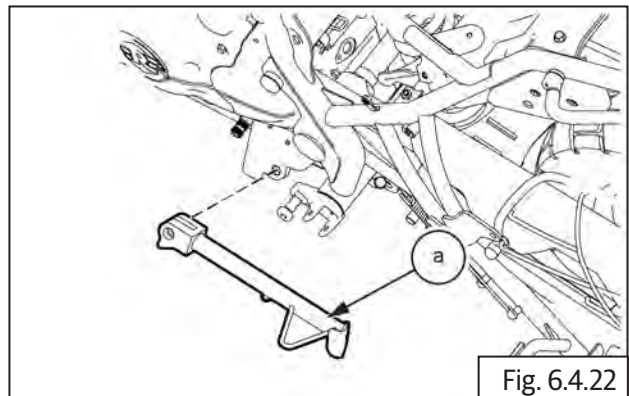

- Insert bolt **(a)** into side stand

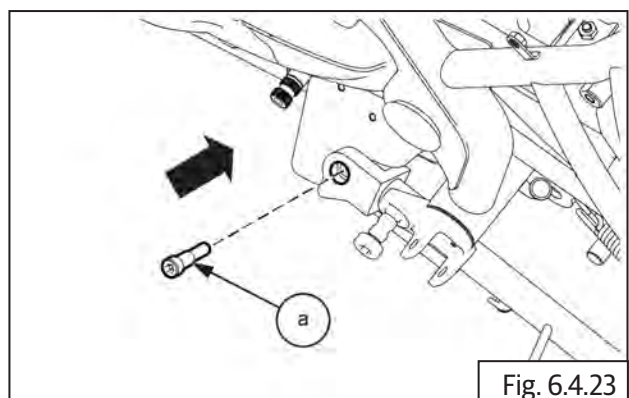

- Install the nut **(a)** at the back of the stand and tighten it

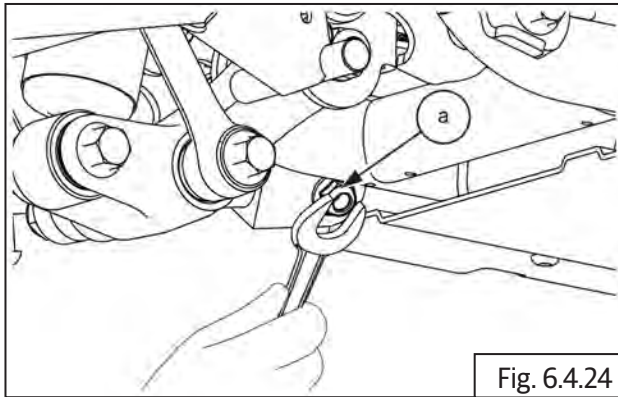



Fig. 6.4.24

	12 mm Socket with Ratchet
Torque	20-30 N·m/2.0-3.0 kgf·m

- Install spring **(a)** in the side stand **(b)**.

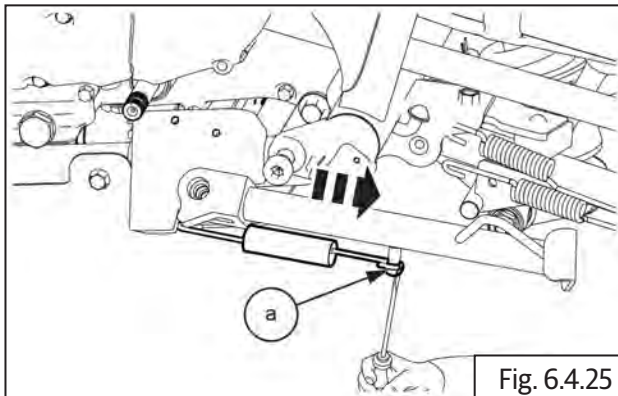

Fig. 6.4.25

	Screw Driver
---	--------------

- Install side stand switch with using 2 Nos. hex bolts **(a)** in the side stand.

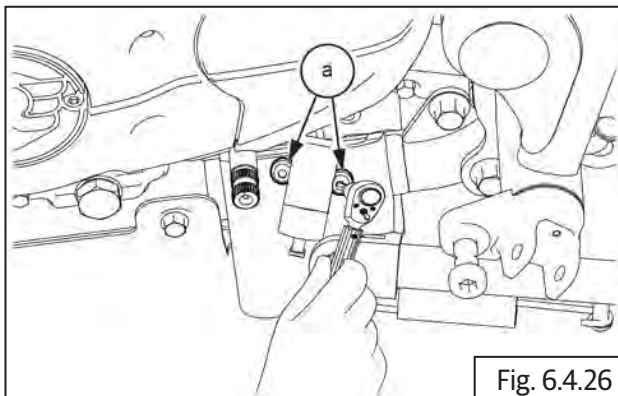

Fig. 6.4.26

Saree Guard Assembly

6.5.8. Saree guard (For Indian market only)

- Locate the saree guard **(a)** at the LH side of the rear wheel.

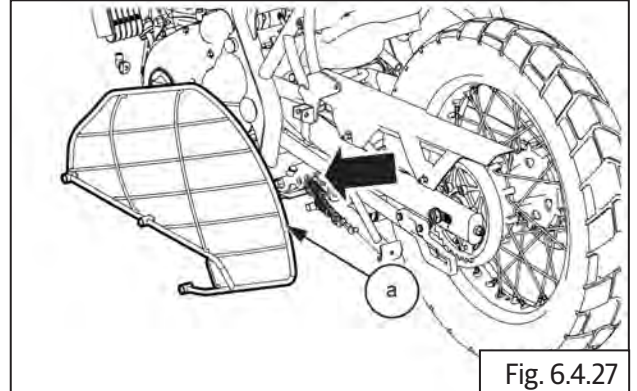

Fig. 6.4.27

- Locate and tighten 3 nos hex flange bolt **(a)** on the LH side of the frame.

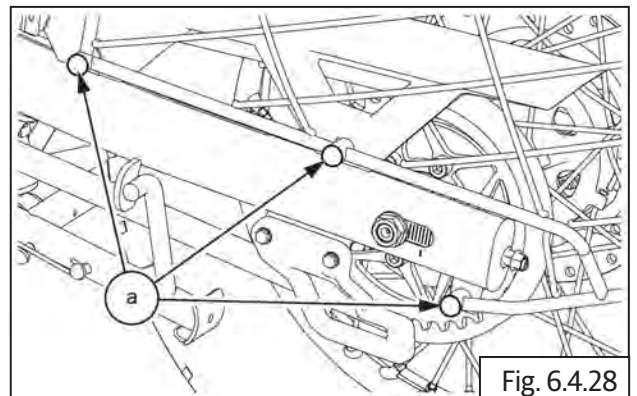



Fig. 6.4.28

	12 mm socket with ratchet
Torque	10-12 N·m/1.0-1.2 kgf·m

MUDGUARDS/NUMBER PLATES/GRAB HANDLE

Mudguards/Number Plates/Grab Handle

CONTENTS	PAGE
6.6 Mudguards/Number Plates/Grab Handle	200
Dismantling.....	200
6.6.1. Front Number Plate (For Indian Market)	200
6.6.2. Front Mudguard.....	200
6.6.3. Rear Number Plate (For Indian Market).....	201
6.6.4. Rear Fender and Mudguard	201
6.6.5. Rear Number Plate Lamp.....	202
Inspection	202
Assembly	203
6.6.6. Rear Number Plate Lamp.....	203
6.6.7. Rear Fender and Mudguard.....	203
6.6.8. Rear Number Plate (For Indian Market).....	204
6.6.9. Front Mudguard	204
6.6.10. Front Number Plate (For Indian Market).....	204

6.6 Mudguards/Number Plates/Grab Handle

Dismantling

6.6.1. Front Number Plate (For Indian Market)

- As per Government norms high security number plates will be provided which are riveted with the vehicle and cannot be removed.

6.6.2. Front Mudguard

Beak Removal

- Loosen and remove 4 Nos. Hex flange bolts (**M6**) (**a**) from bottom of the beak.

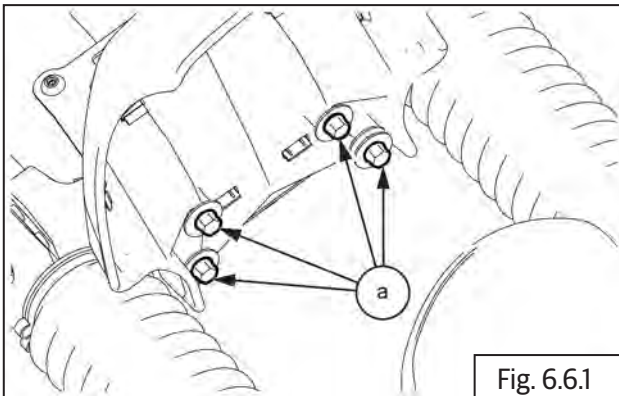

5 mm Allen socket with Ratchet

- Gently push the beak downward and remove from fork ends.

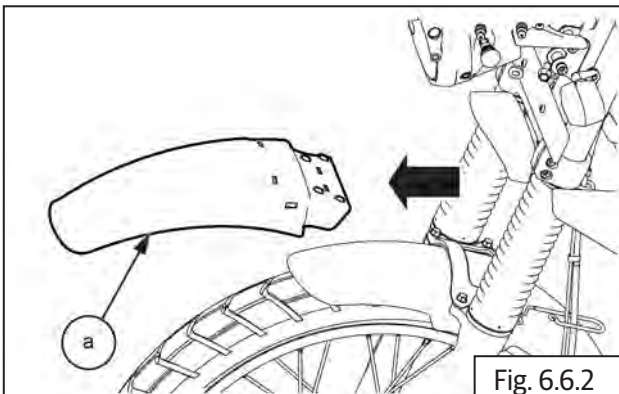

Mudguard Removal

- Loosen and remove 4 Nos. Hex flange bolts (**M6**) (**a**) from fork brace.

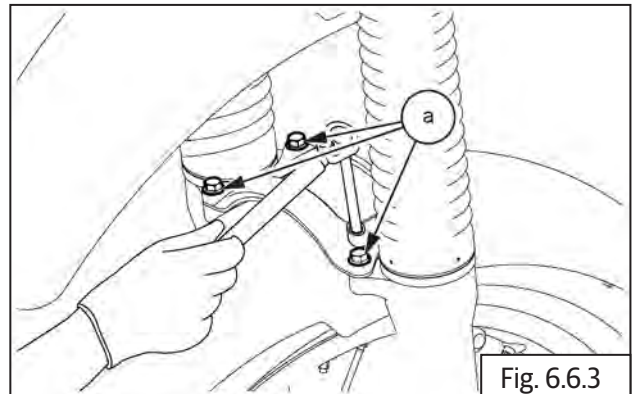

5 mm Allen socket with Ratchet

- Slightly push mudguard downwards, tilt it to one side and remove along with the fork brace.

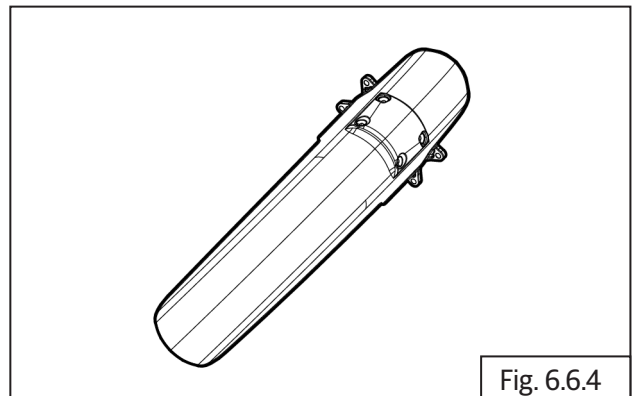

- Gently remove the fork brace (**a**) from the mudguard.

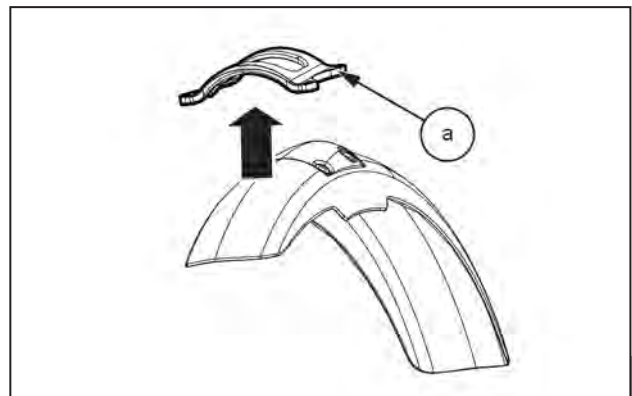

6.6.3. Rear Number Plate (For Indian Market)

- As per Government norms high security number plates will be provided which are riveted with the vehicle and cannot be removed.

6.6.4. Rear Fender and Mudguard

- Loosen and remove 2 Nos. Hex bolts (a) from the mudguard bottom.

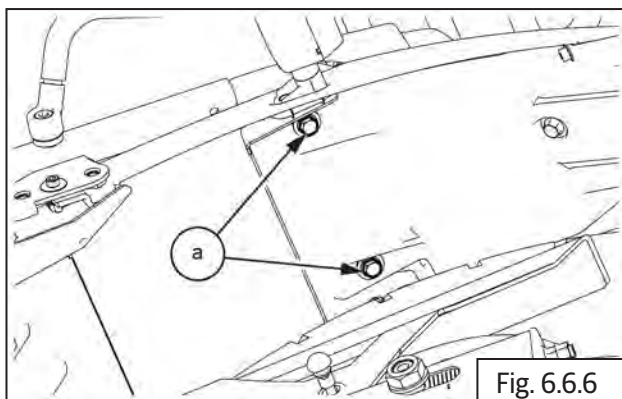

- Loosen and remove 1 No. Allen bolts (a) from both LH side.

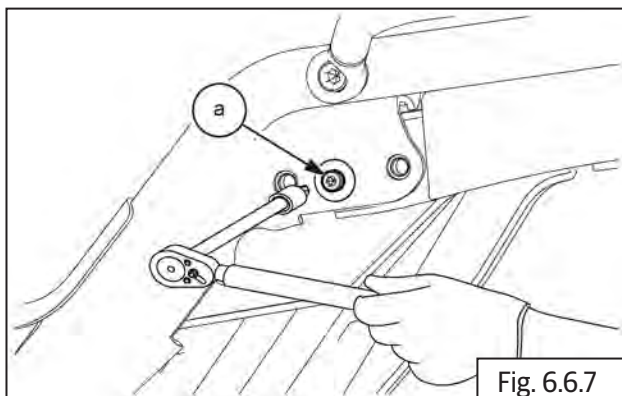

- Loosen and remove 1 No. Allen bolts (a) from both RH side.

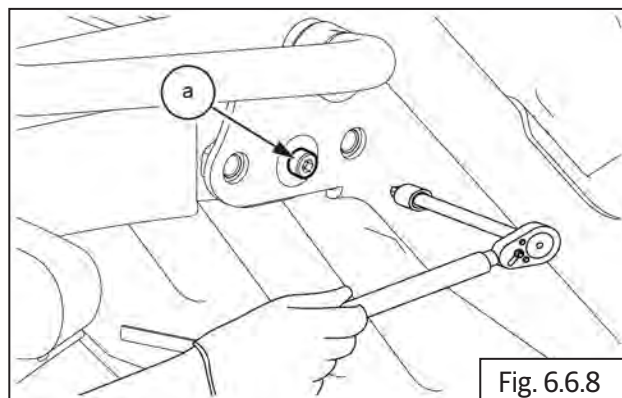

- Loosen and remove 2 Nos. Allen bolts (a) and 1 No. Hex Bolt (b) (M5) along with washer from the mudguard bottom.

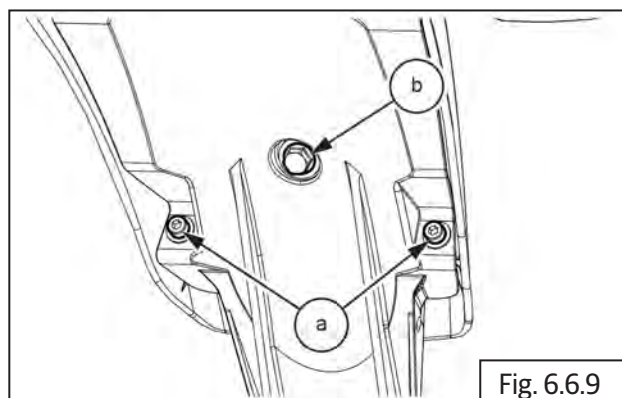

- Separate the fender from mudguard.
- Disconnect the electrical couplers.
- Remove the mudguard from the frame.

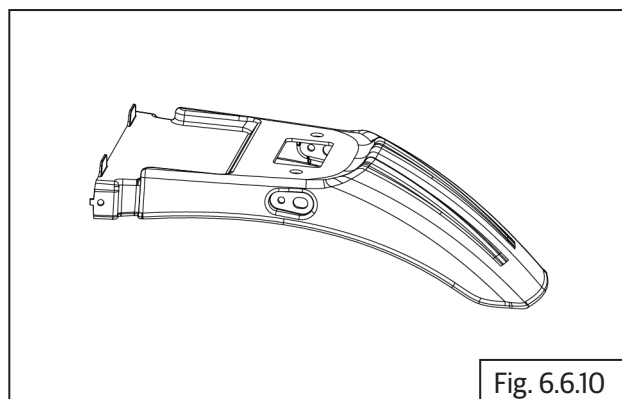

6.6.5. Rear Number Plate Lamp

- Loosen and remove 2 Nos. allen bolts **(a)** along with washer from rear fender bottom **(b)**.

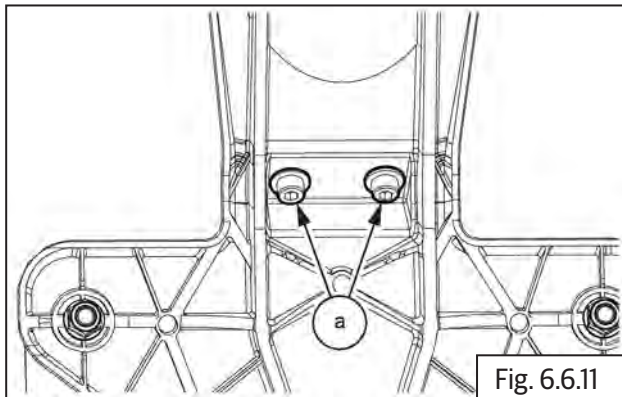

4 mm Allen with Ratchet

- Disconnect the electrical coupler.
- Separate the Number plate lamp **(a)** from the fender.

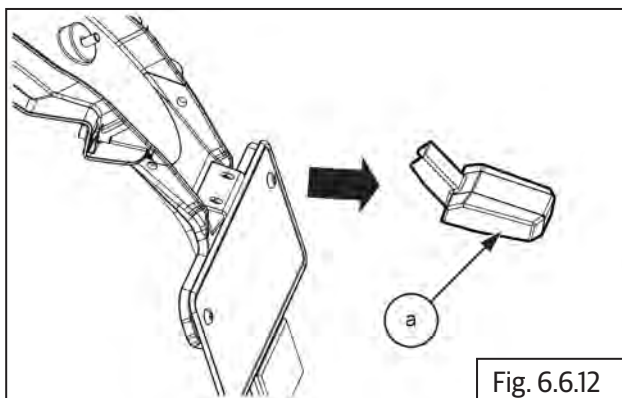

Inspection

Mudguard/Reflector/Grab handle

- Clean Mudguard. Inspect for any scratches, cracks, damages on mudguard and replace if required.
- Inspect Infill rear mud cover for any cracks or damages. Replace if required.
- Inspect rear reflector for any cracks or damages. Replace if required.
- Inspect grab handle for any cracks, bends or damages and replace if required.

Front and Rear number plates

- Inspect number plates and bracket for rust formation and cracks. Replace if required.

Assembly

6.6.6. Rear Number Plate Lamp

- Align the number plate lamp on the fender.
- Connect the electrical coupler.
- Install the 2 Nos. Allen bolt **(a)** along with washers on the bottom of the fender.

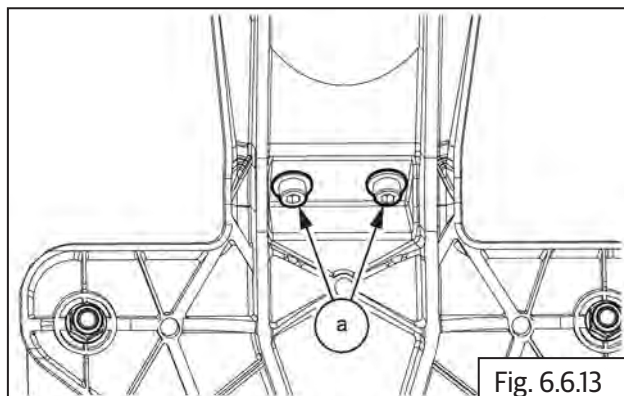

6.6.7. Rear Fender and Mudguard

- Align the rear fender with the mudguard **(a)**.

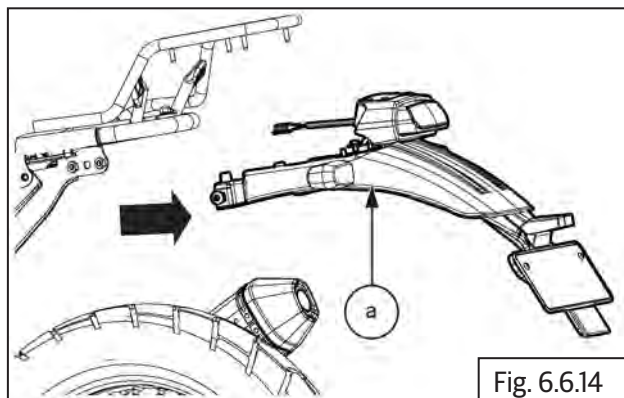

- Install the 2 Nos. Allen bolts **(a)** and 1 No. Hex bolt **(b) (M5)** along with washer on the mudguard bottom.

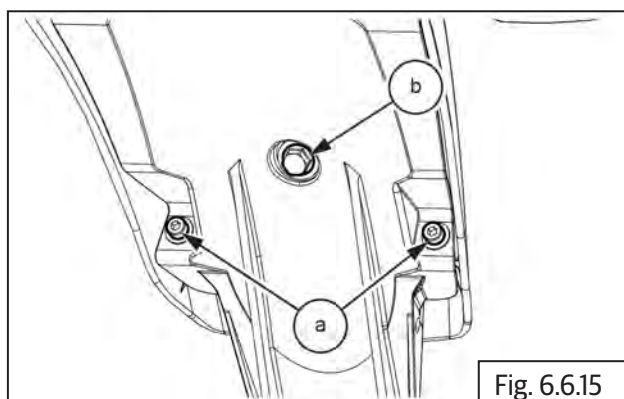

- Install the 1 No. Allen bolts **(a)** on both RH side.

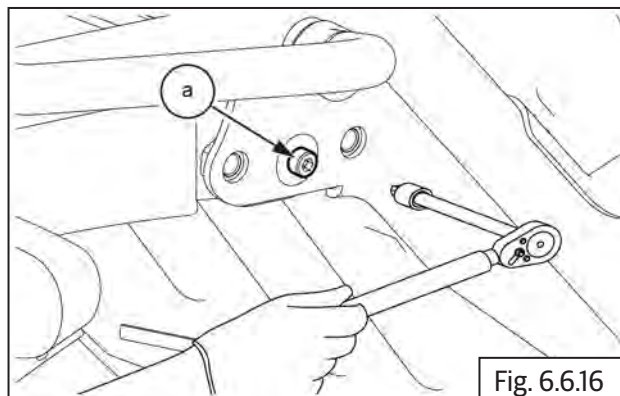

- Install the 1 No. Allen bolts **(a)** on both LH side.

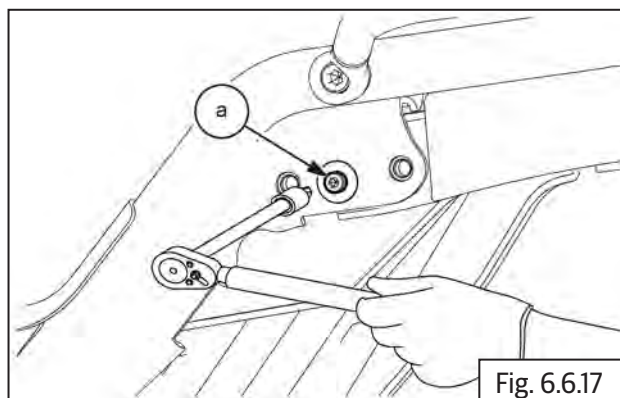

	4 mm Allen with Ratchet
Torque	3-5 N-m/0.3-0.5 kgf-m

- Install 2 Nos. Hex bolts **(a)** on the bottom of the mudguard.

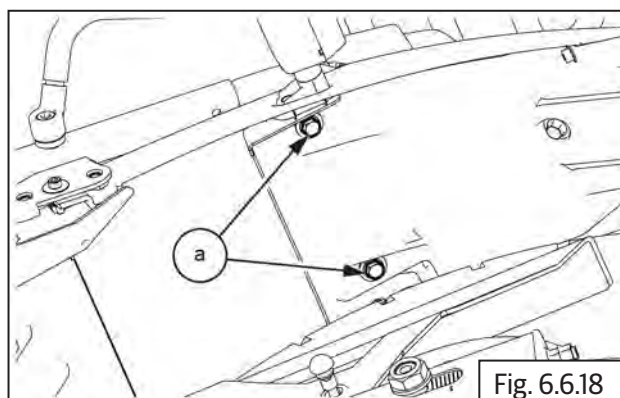

6.6.8. Rear Number Plate (For Indian Market)

- As per Government norms high security number plates will be provided which are riveted with the vehicle and cannot be removed.

6.6.9. Front Mudguard

Mudguard Removal

- Locate the fork brace (a) on the mudguard.

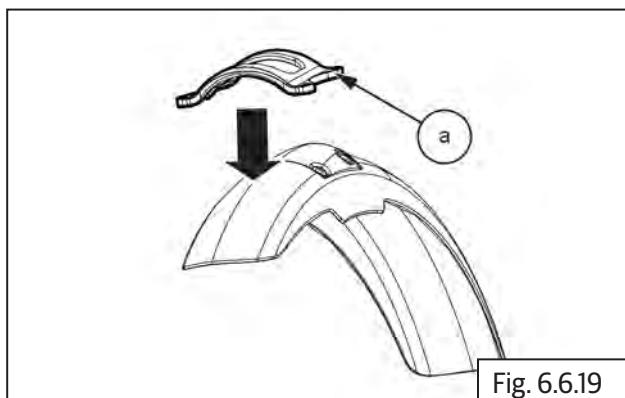

	5 mm Allen socket with Ratchet
Torque	3 N-m/0.3 kgf-m

- Ensure handlebar is turned to one side, tilt front mudguard and insert between the fork legs.
- Locate and tighten 4 Nos. Hex flange bolts (M6) (a) and fix mudguard on to fork.

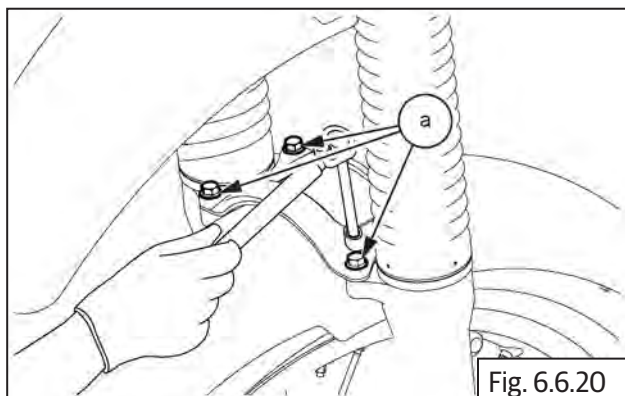

	5 mm socket with Ratchet
Torque	10 N-m/1 kgf-m

Beak Removal

- Align the beak (a) between the fork.

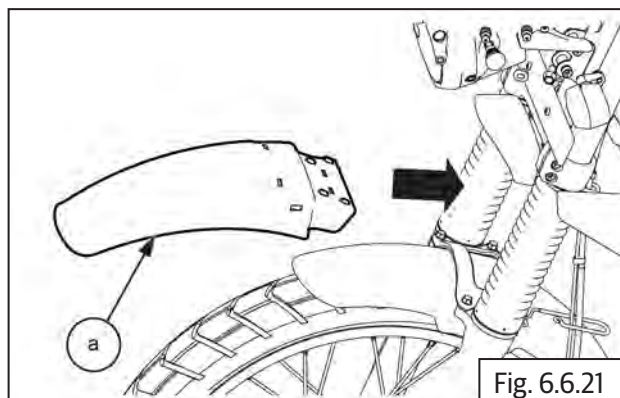

- Install 4 Nos. Hex flange bolts (M6) (a) on the bottom of the beak.

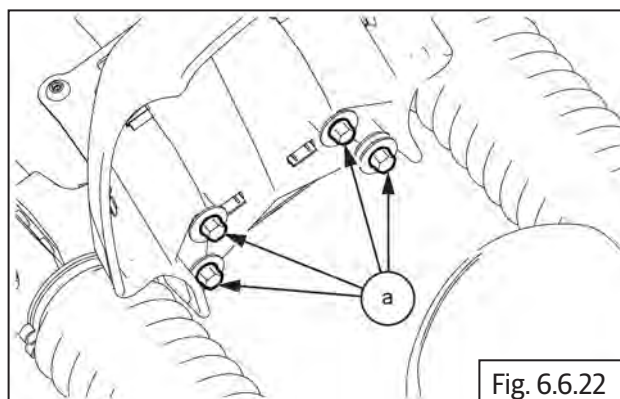

6.6.10. Front Number Plate (For Indian Market)

- As per Government norms high security number plates will be provided which are riveted with the vehicle and cannot be removed.

SIDE PANELS AND RIDER SEAT

Side Panels and Rider Seat

CONTENTS	PAGE
6.7 Side Panels and Rider Seat	207
Dismantling	207
6.7.1. Side Panel RH	207
6.7.2. Side Panel LH.....	207
6.7.3. Pillion and Rider Seat from Frame	208
6.7.4. Grab Rail from Frame	208
Assembly	209
6.7.5. Grab Rail on Frame	209
6.7.6. Rider and Pillion Seat Assembly on Frame	209
6.7.7. Side Panel LH	209
6.7.8. Side Panel RH	210

6.7 Side Panels and Rider Seat

Dismantling

6.7.1. Side Panel RH

- Remove 3 Nos. Hex socket button head screws (**a**) (except right bottom one).

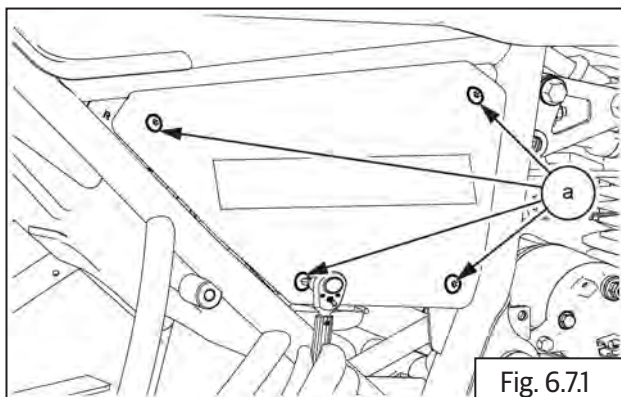

- Gently pull the LH cover (**a**) and remove.

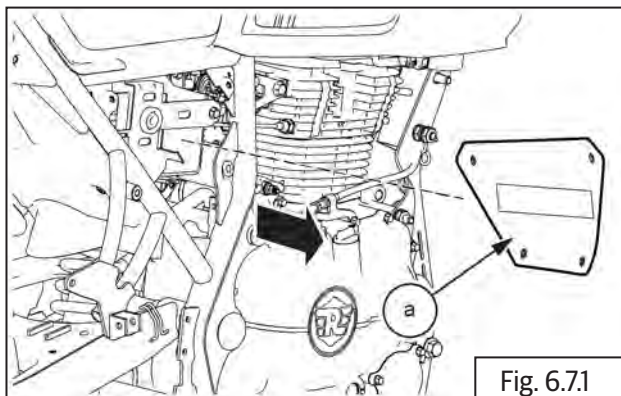

6.7.2. Side Panel LH

- Remove 3 Nos. Hex socket button head screws (**a**) (except left bottom one).

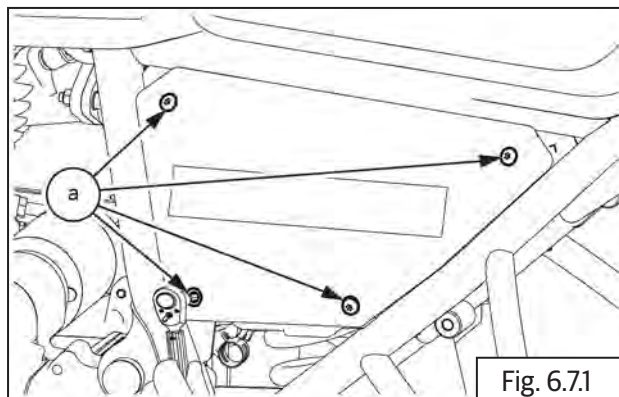

- Gently pull the LH cover (**a**) and remove.

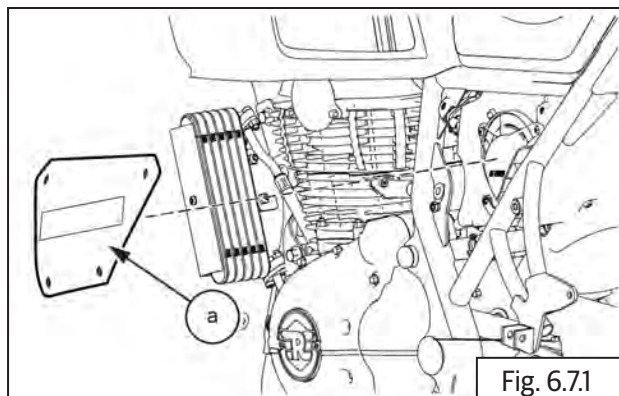

6.7.3. Pillion and Rider Seat from Frame

- Insert ignition key and turn clockwise to unlock.

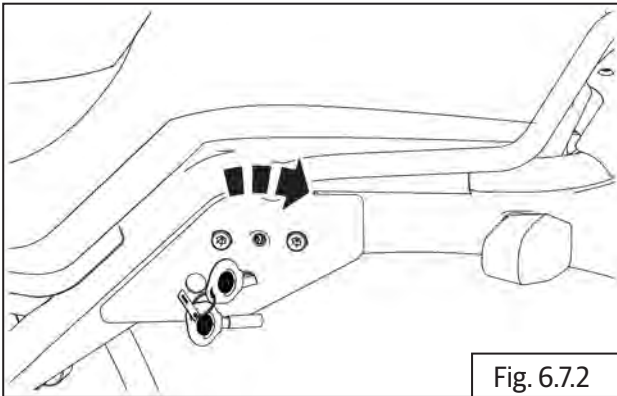

- Remove pillion seat (a).

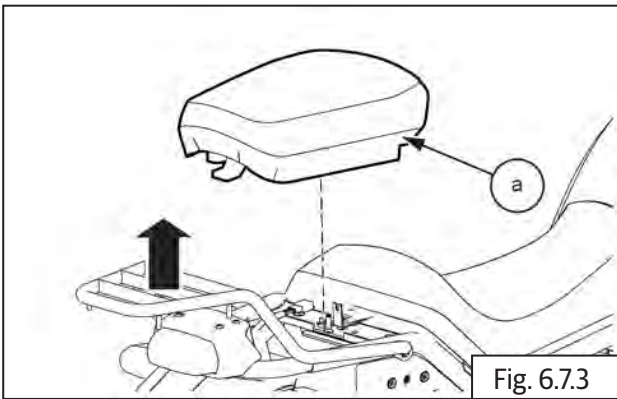

- Gently pull and remove rider seat (a).

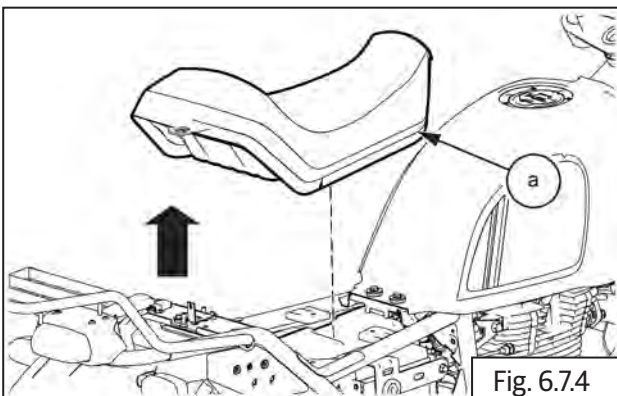

NOTE

- Place the seat in a safe location to prevent from scratches and dirt.

6.7.4 Grab Rail from Frame

- Remove the 1 No. allen bolt (a) on both RH and LH side from the grab rail.

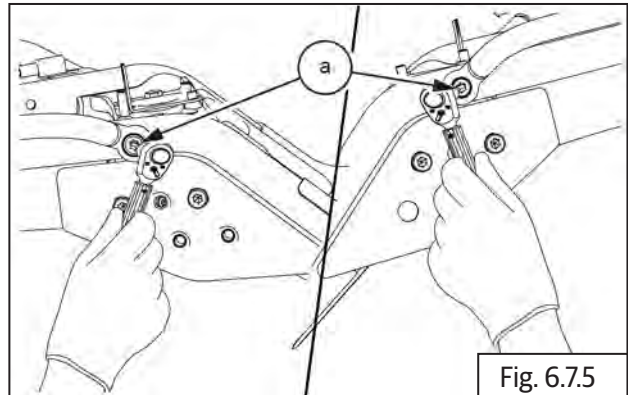

- Remove the 2 Nos. allen bolts (a) from the mudguard.

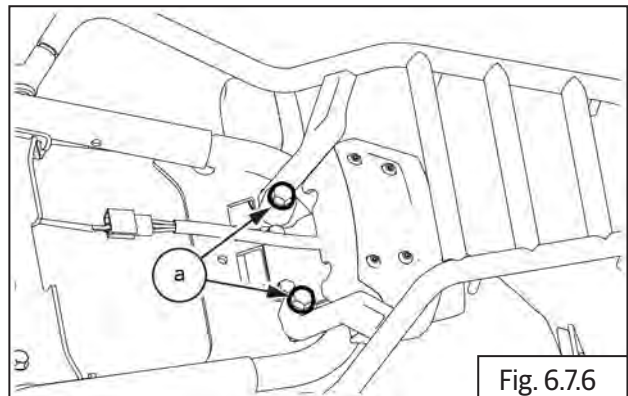

- Gently remove the grab rail (a).

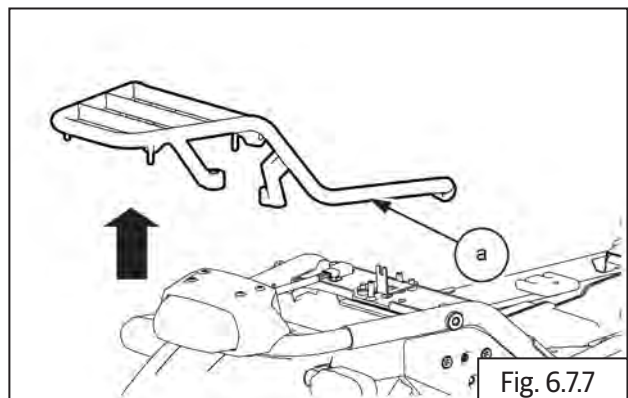

Assembly

6.7.5. Grab Rail on Frame

- Align the grab rail and install 2 Nos. allen bolts (a) on the mudguard.

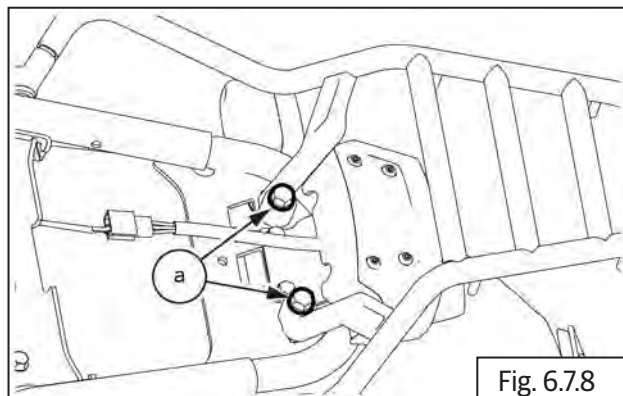

- Install 1 No. allen bolt (a) on both LH and RH side.

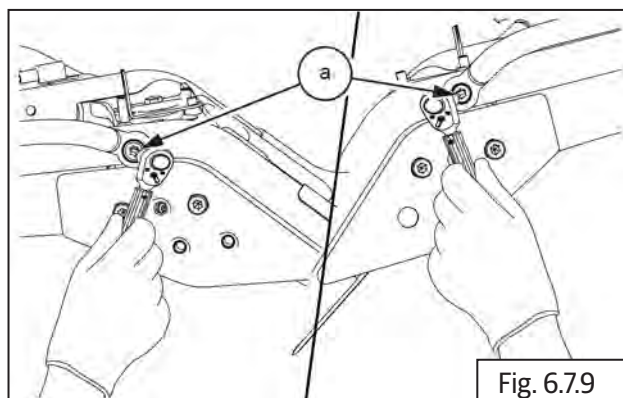

	6 mm Allen Socket with Ratchet
Torque	

6.7.6. Rider and Pillion Seat Assembly on Frame

- Locate the rider seat (a) over the frame.

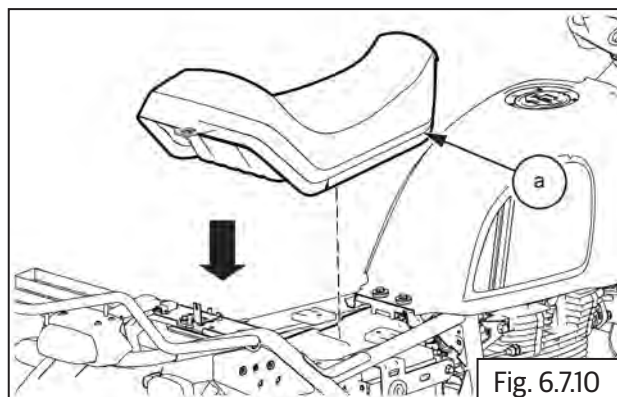

- Locate the pillion seat (a) over the lock.
- Press and lock the pillion seat.

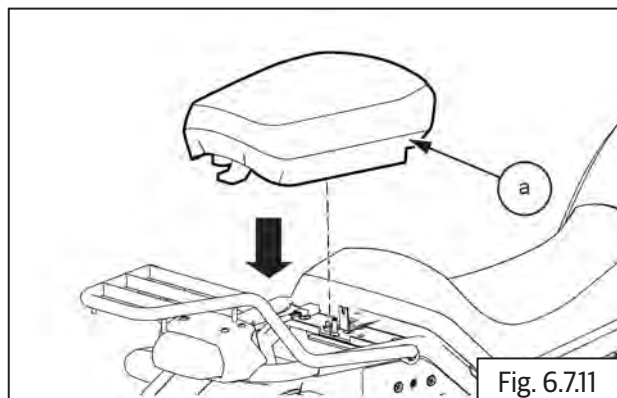

6.7.7. Side Panel LH

- Align LH panel to fit into frame (a) and lock it.

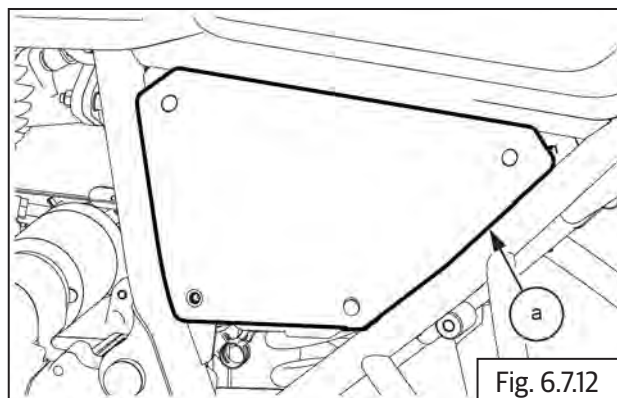

- Install 3 Nos. Hex socket button head screws (**a**) (except left bottom one).

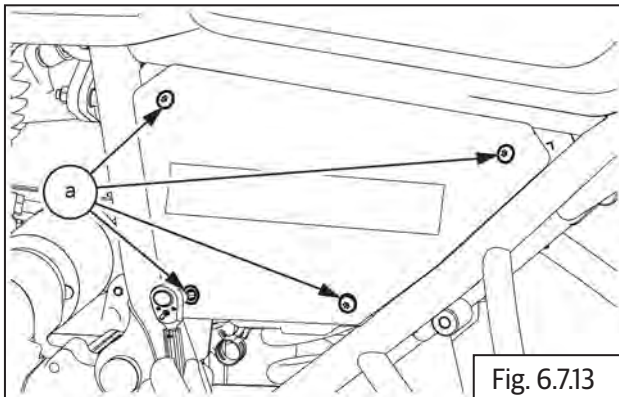

Fig. 6.7.13



5 mm Allen Key

6.7.8. Side Panel RH

- Locate side panel RH into frame and lock in its position.

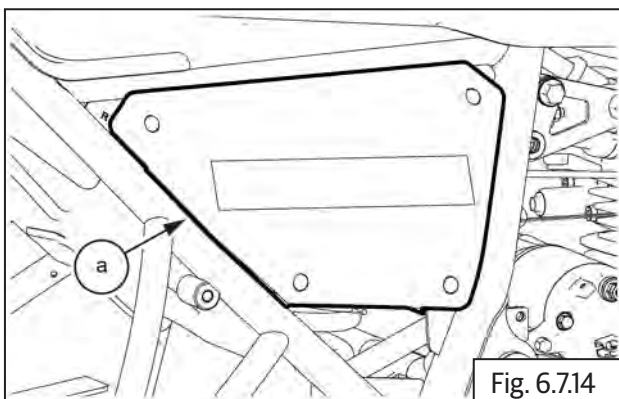

Fig. 6.7.14

- Install 3 Nos. Hex socket button head screws (**a**) (except left bottom one)

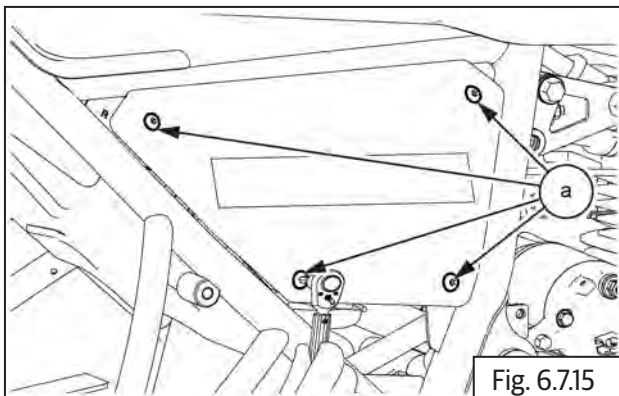

Fig. 6.7.15



5 mm Allen Key

WHEELS

CONTENTS

PAGE

6.8 Wheels	213
Dismantling.....	213
6.8.1. Front Wheel Assembly.....	213
6.8.2. Front Wheel and Brake Disc.....	214
6.8.3. Rear Wheel from Swing Arm.....	216
6.8.4. Rear Wheel and Brake Disc	218
Inspection	220
6.8.5. Front Wheel and Brake Disc.....	220
6.8.6. Rear Wheel and Brake Disc.....	223
Assembly	225
6.8.7. Tyre Assembly On Wheel Rim	225
6.8.8. Rear Wheel and Brake Disc.....	225
6.8.9. Rear Wheel into Swing Arm.....	228
6.8.10. Drive Chain Free Play Adjustment.....	229
6.8.11. Tyre Assembly on Wheel Rim.....	231
6.8.12. Front Wheel and Front Brake Disc	231
6.8.13. Front Wheel into Front Fork Assembly	232
Troubleshooting.....	234

6.8 Wheels

Dismantling

6.8.1. Front Wheel Assembly

CAUTION

Ensure the motorcycle is upright on a firm and flat surface.

- Locate a scissor jack **(a)** under the cradle frame **(b)** and lift motorcycle such that the front wheel is off the ground by minimum 6 inches (or 15 cm).

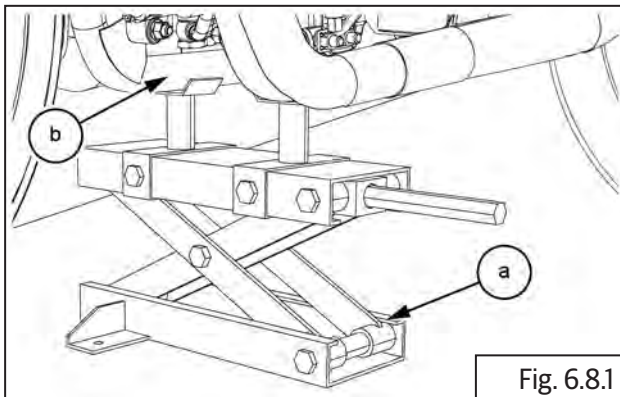

- Hold spindle **(a)** from LH with tommy bar and loosen Hex nut **(M16) (b)** from RH.

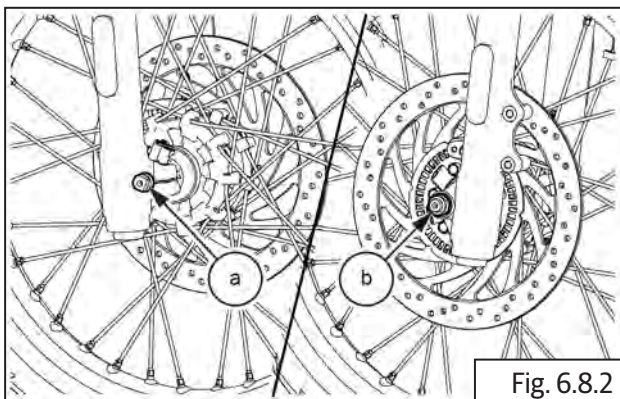

24 mm Socket with Ratchet and Tommy Bar

- Remove the Hex nut **(a)**, washer **(b)** from the spindle RH **(c)**.

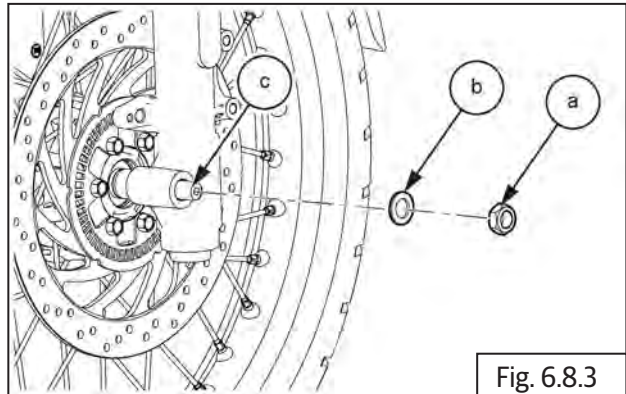

- Loosen Hex socket head bolt **(M6) (a)** from front fork assembly RH.

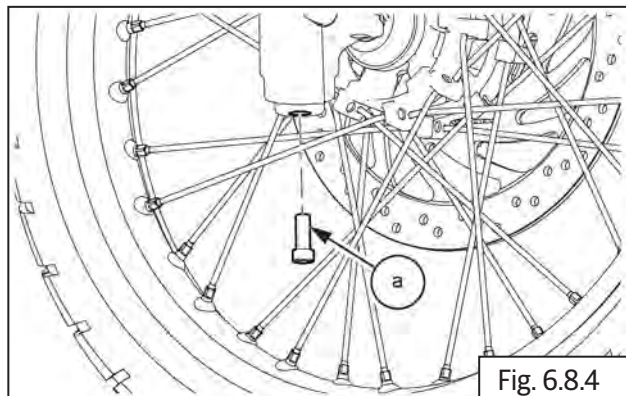

5 mm Allen key

- Gently tap spindle **(a)** using mallet **(b)** from RH.

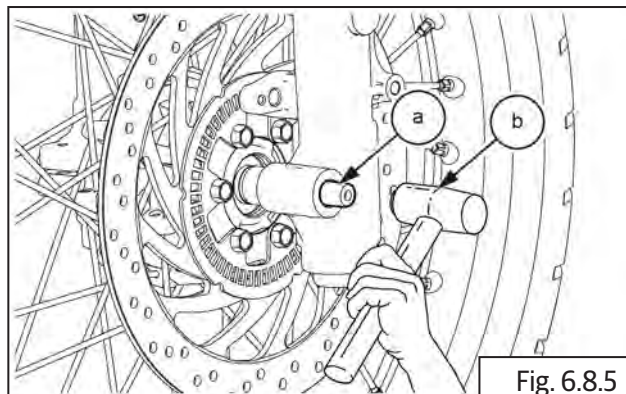

Mallet

- Gently remove spindle (a) from wheel hub and front fork assembly LH (b).

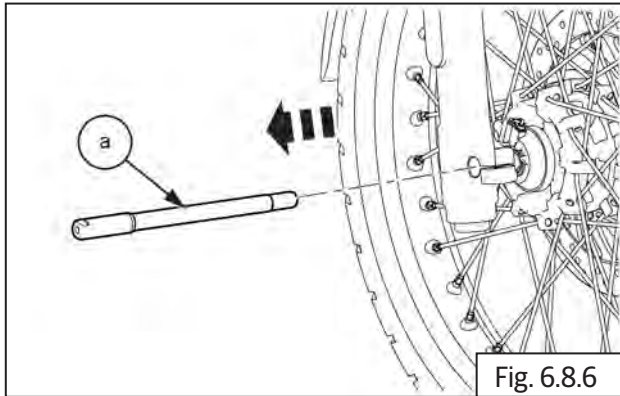

CAUTION

Ensure the wheel speed sensor cable does not get stretched and damaged. Support wheel from bottom while removing spindle.

- Gently lower the wheel (a) such that it comes out of the fork legs (b).

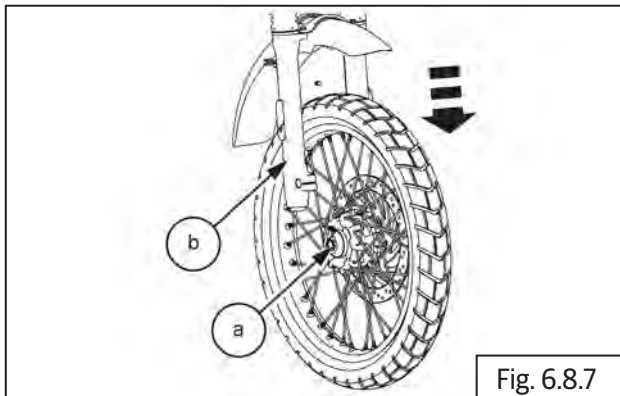

- Remove spacer (a) from wheel hub (b) on LH.

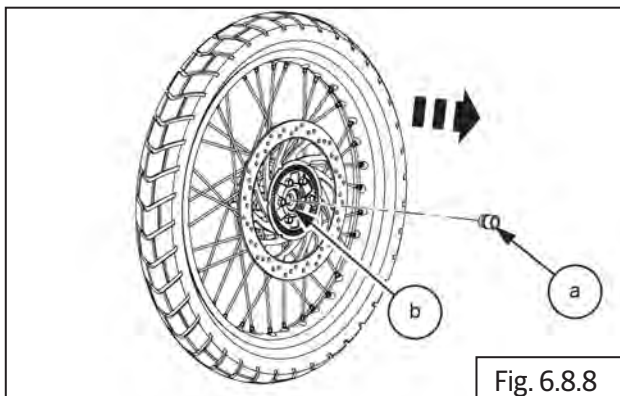

6.8.2. Front Wheel and Brake Disc

WARNING

DO NOT place/store the wheel with disc facing downward. It will damage and change disc warpage.

CAUTION

Place a soft cloth under the wheel hub center mounting hole area to prevent damage. Please loosen thread sealant applied screws with care.

- Loosen and remove 5 Nos. Hex socket head bolts (M6) (a) holding disc plate to hub, in crisscross pattern.

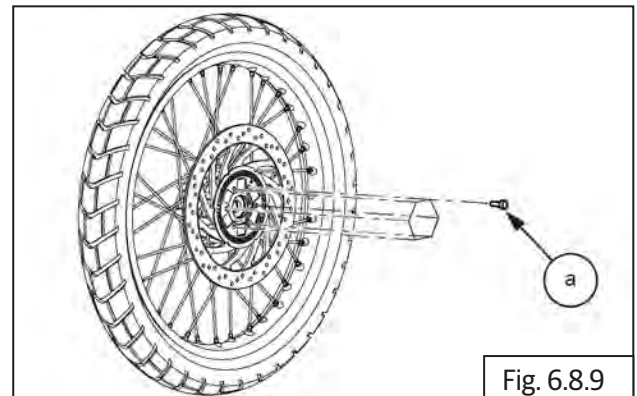

 6 mm Allen socket with Ratchet

- Remove toner wheel front (a) from hub and store carefully.

CAUTION

Avoid any bends or damages to the toner wheel as it will affect the functioning of ABS.

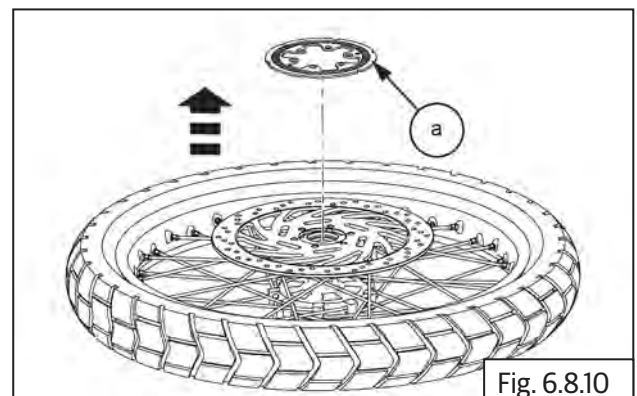

- Remove front brake disc **(a)** from hub and store carefully.

⚠ CAUTION

Ensure the brake disc does not get damaged as it will affect the brake efficiency.

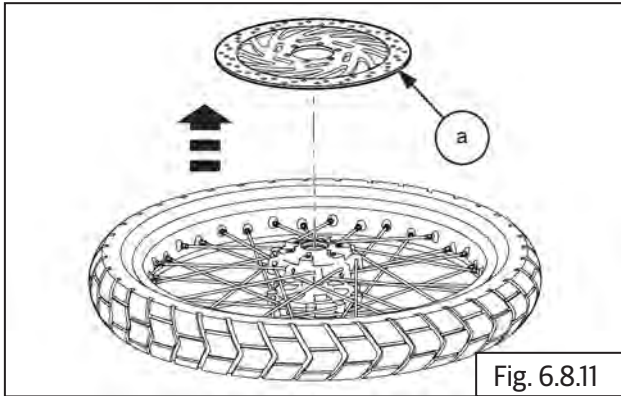

- Insert a punch into hub from LH side and drive out bearing RH **(a)**.

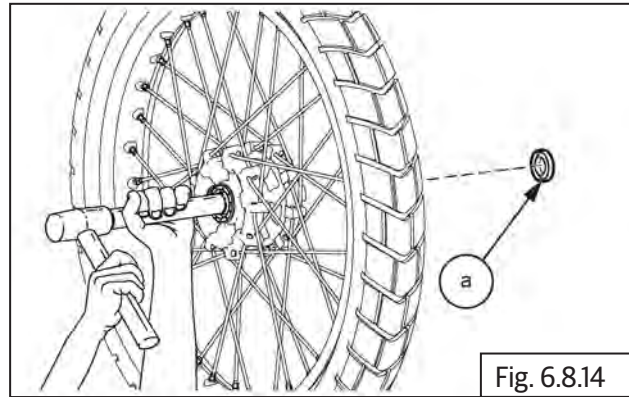

Punch and Mallet

- Remove grease seal **(a)** from LH.

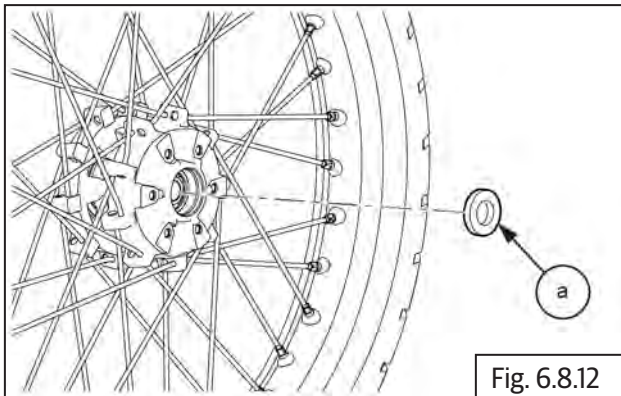

- Locate a suitable pointed punch on hole in spacer from RH of hub to remove bearing LH **(a)** along with spacer **(b)**.

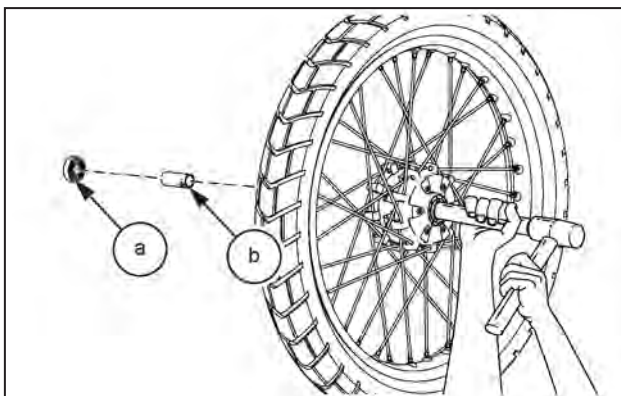

Punch and Mallet

6.8.3. Rear Wheel from Swing Arm

CAUTION
Ensure the motorcycle is upright on a firm and flat surface.

- Position the vehicle in main stand. Make sure it is located in a flat surface.

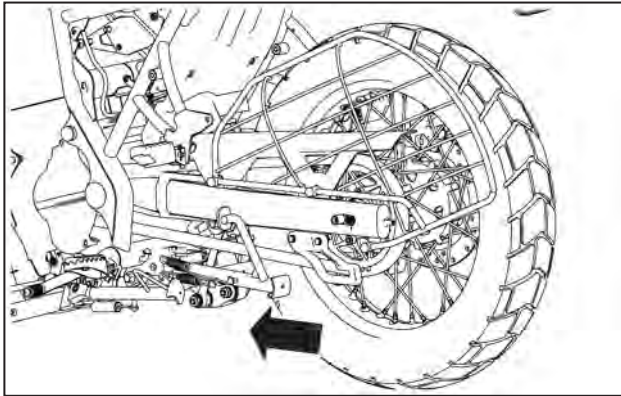

- Loosen and remove Hex axle nut **(M16) (b)** from RH and hold other side LH with tommy bar **(a)**.

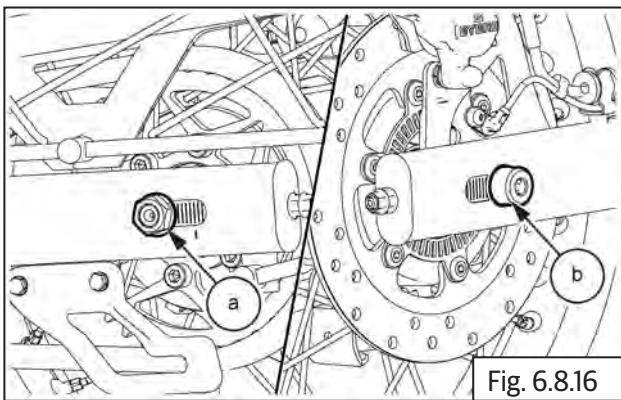

 24 mm Ring spanner and Tommy bar

- Remove washer **(a)** from spindle **(b)** on swing arm LH.

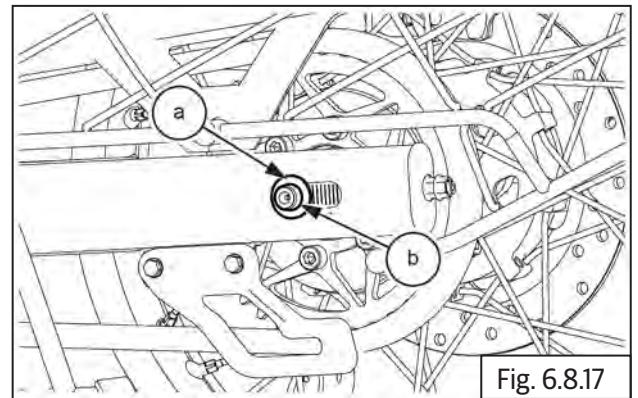

- Loosen Allen bolt **(M8) (a)** on both LH and RH chain adjusters.

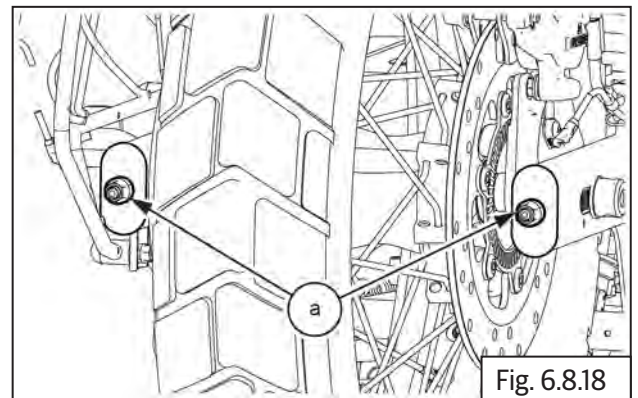

 6 mm Allen Key

- Push rear wheel forward to increase chain slack on rear sprocket.

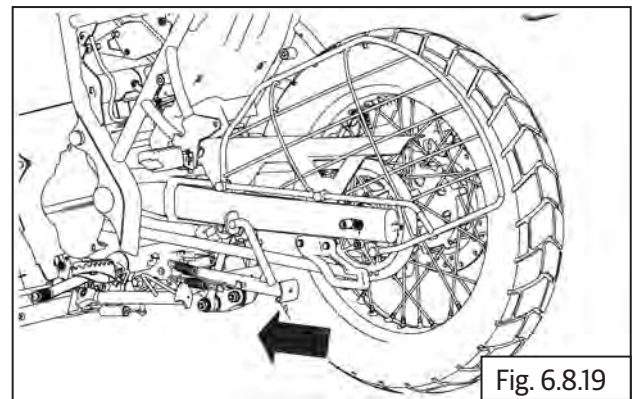

- Remove chain adjuster assembly **(a)** from swing arm RH **(b)**.

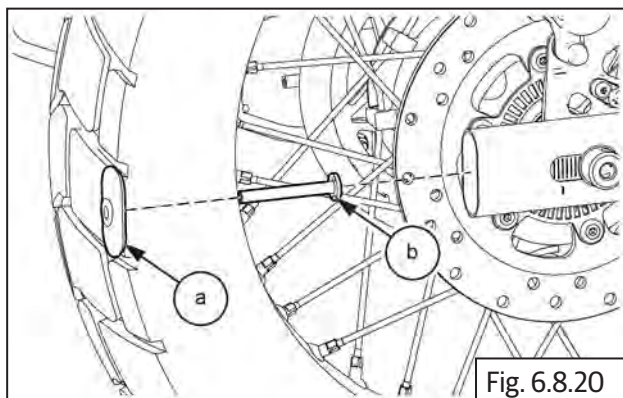

- Remove spindle **(a)** from rear wheel RH along with washer **(b)**.

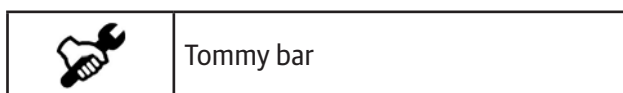
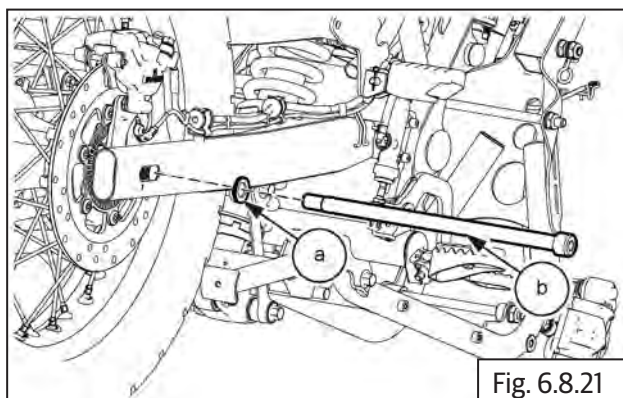

- Gently remove chain adjuster assembly **(a)** from swing arm LH **(b)**.

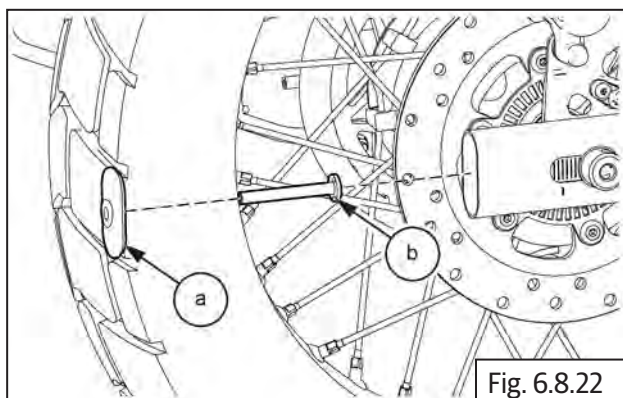

- Slide out and remove brake caliper **(a)** with bracket.

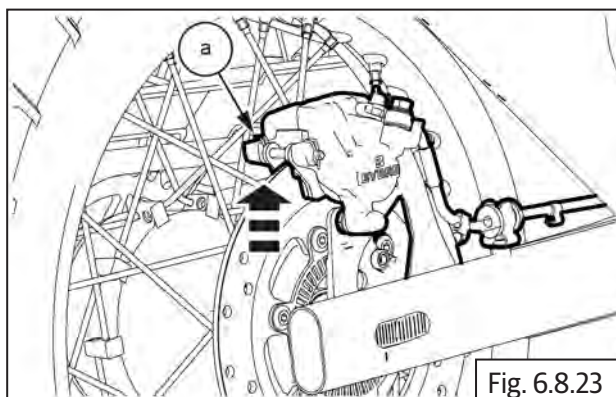

CAUTION

Support the caliper carefully and ensure it does not get damaged.

- Ensure limiter pad **(a)** is placed between brake pads in caliper assembly.
- Gently release drive chain **(a)** from sprocket **(b)**.

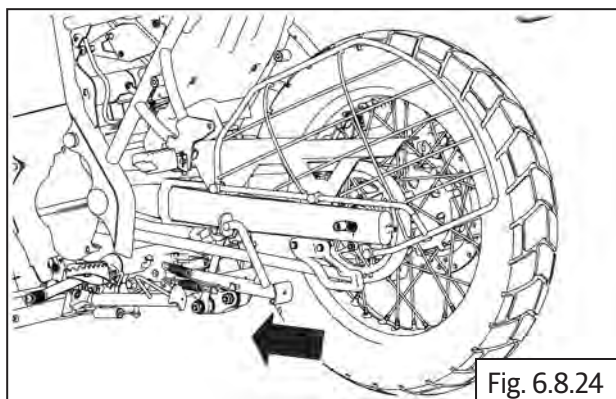

- Gently remove spacer RH **(a)** from the rear wheel hub **(b)**.

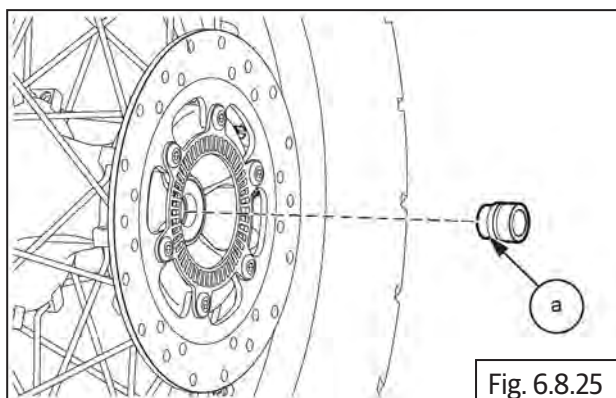

- Gently remove rear wheel **(a)** from swing arm **(b)**.

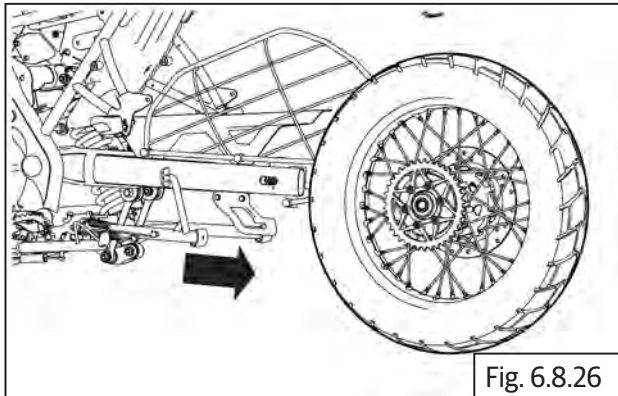

6.8.4. Rear Wheel and Brake Disc

- Loosen and remove 6 Nos. Hex flanged socket head bolts **(M8) (a)** to remove chain sprocket **(b)**.

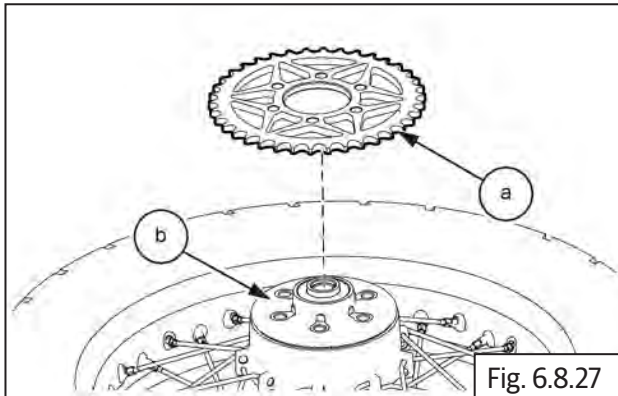

- Remove chain drive sprocket **(a)** from sprocket carrier **(b)**.

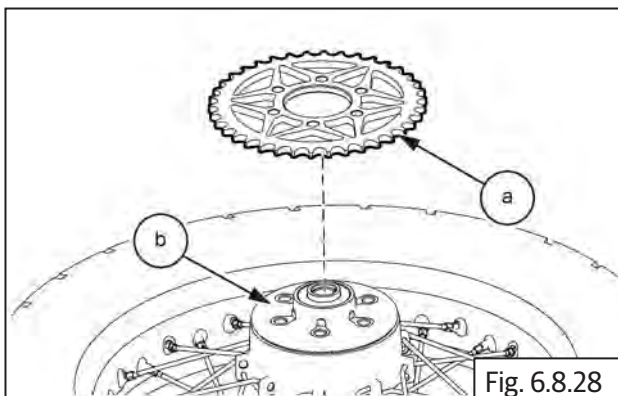

- Remove sprocket carrier **(a)** from the rear wheel hub **(b)**.

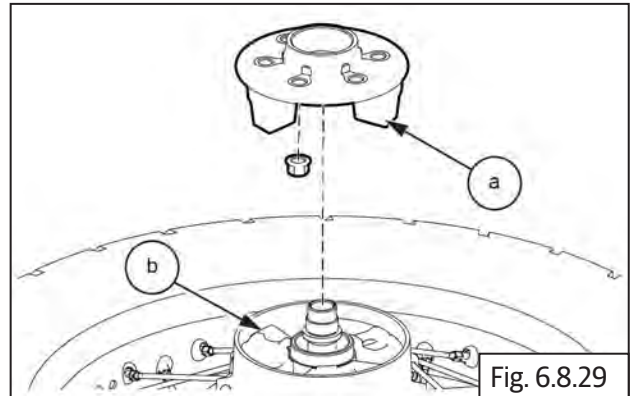

- Remove 4 Nos. cush rubbers **(a)** from rear wheel hub LH **(b)**.

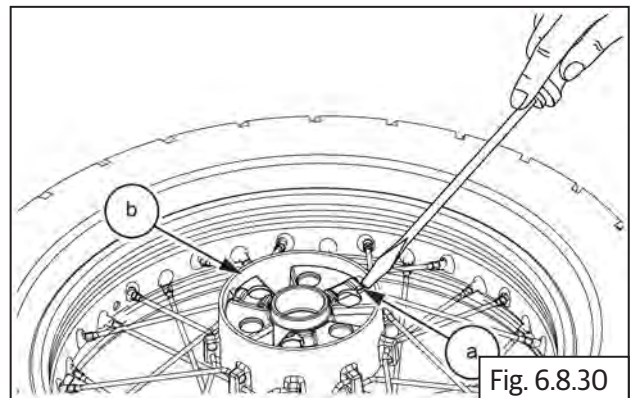

- Loosen and remove 6 Nos. Hex head button socket screws **(M6) (a)** to remove ABS toner.

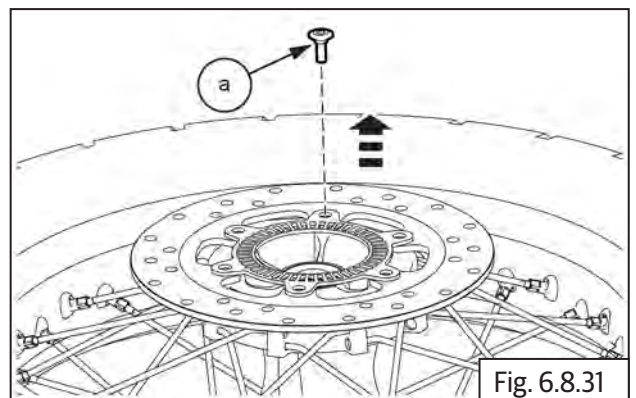

- Remove ABS toner wheel **(a)** from rear wheel RH.

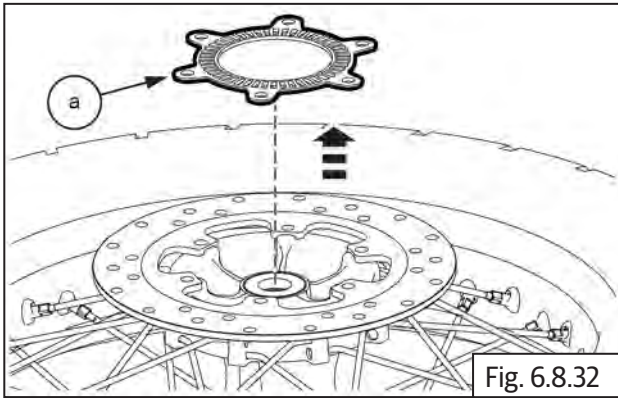

- Remove rear brake disc **(a)** from the rear wheel hub RH **(b)**.

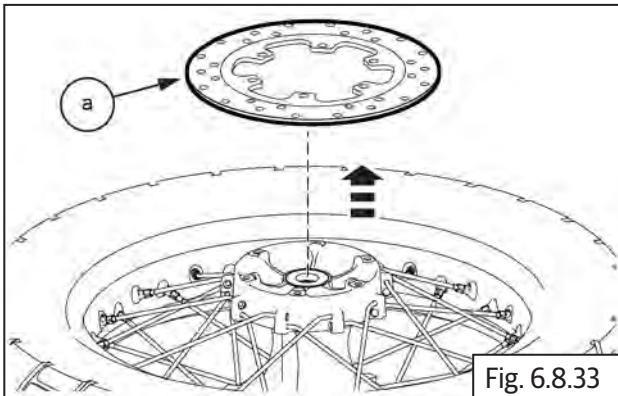

- Remove grease seal **(a)**.

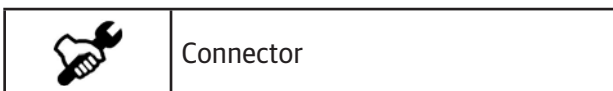
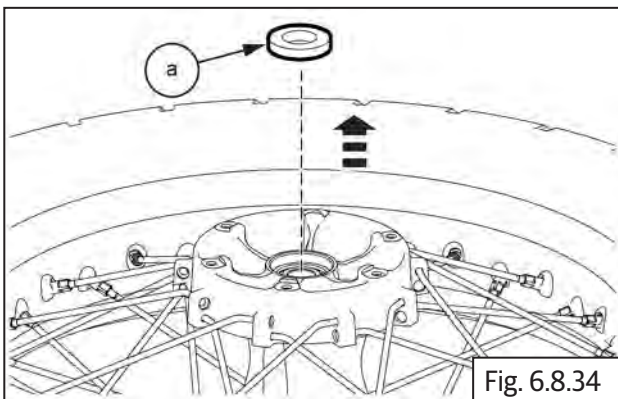

- Insert a punch **(a)** into hub **(b)** from LH side and drive out bearing RH **(c)**.

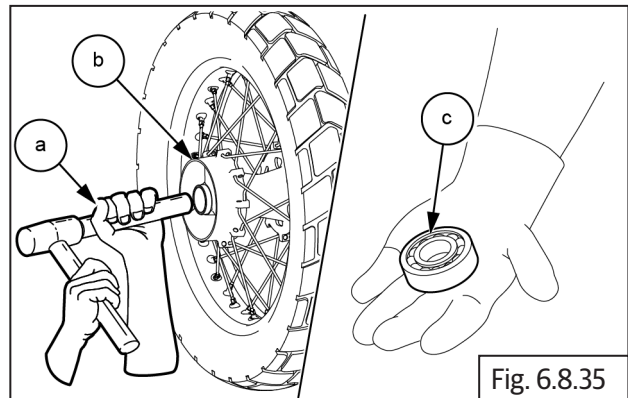

- Locate a suitable pointed punch **(a)** on hole in spacer from RH of hub **(b)** to remove bearing LH **(c)**.

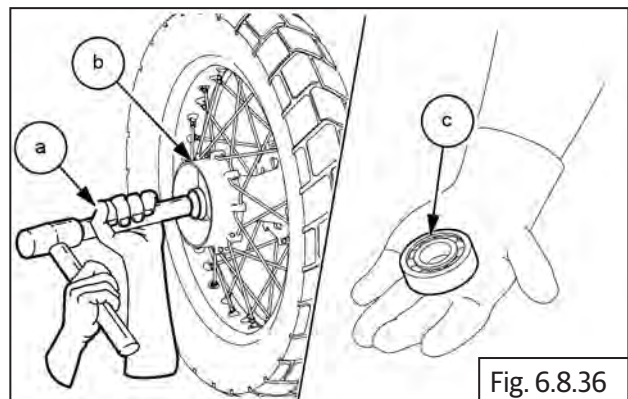

- Remove spacer **(a)** from the rear wheel hub RH.

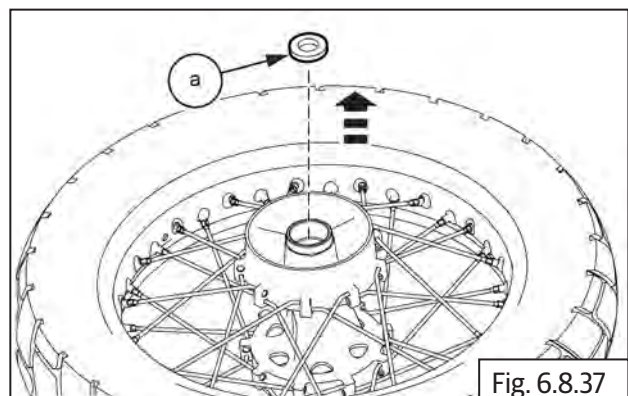

- Gently tap to remove spacer **(a)** from sprocket carrier **(b)**.

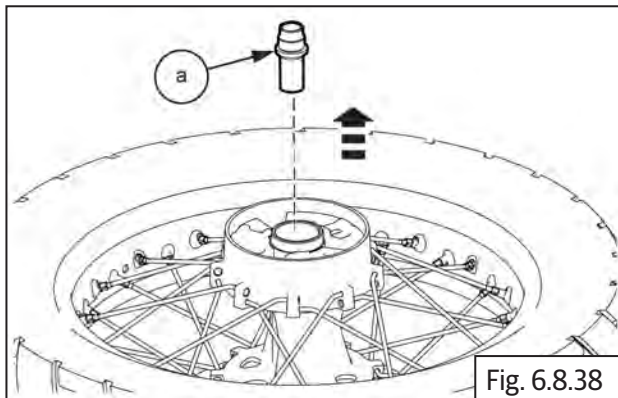

! CAUTION
DO NOT apply excessive force to remove the bearing, spacer as it may cause damage.

- Gently remove grease seal **(a)** from the sprocket carrier **(b)**.

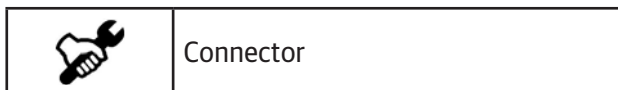
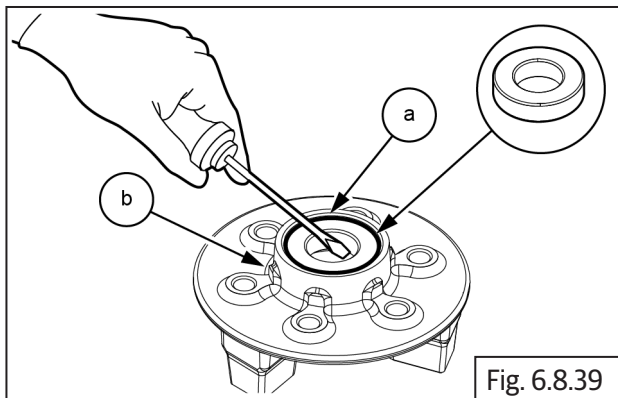

- Gently remove bearing **(a)** from the sprocket carrier **(b)**.

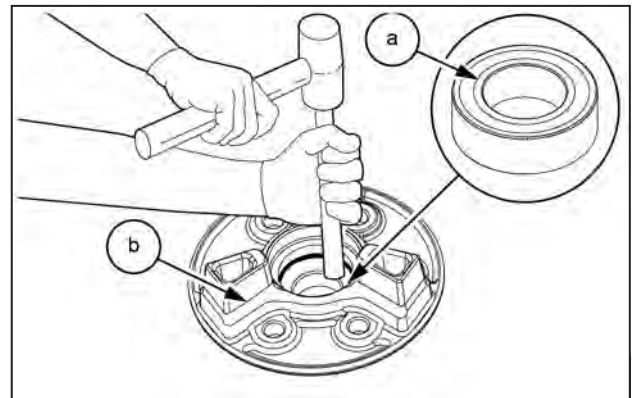

Inspection

6.8.5. Front Wheel and Brake Disc

- Inspect tyre condition and wheel rim for any damages or bends and replace if out of specifications.

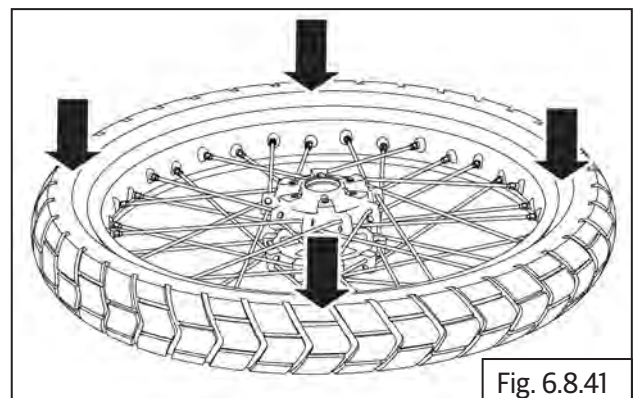

- Inspect and replace spindle **(a)** if it has excess wear, rust or bends.

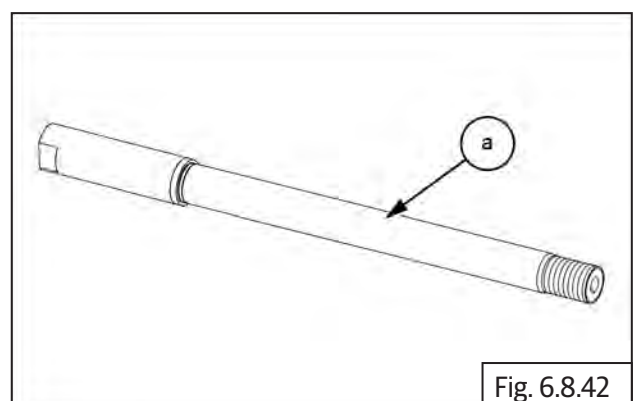

- Check tyres for any uneven wear out and the sipes on the center of the tyre is above the TWI index.

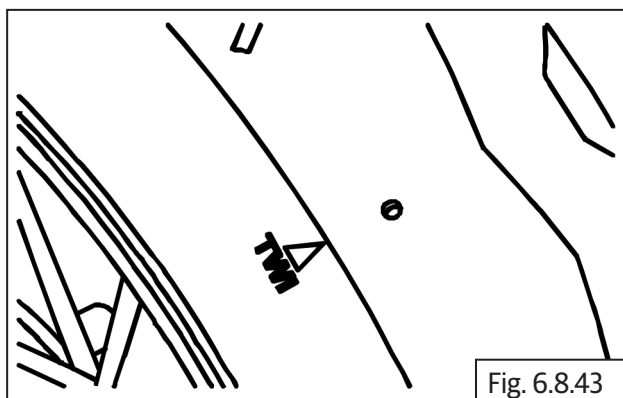
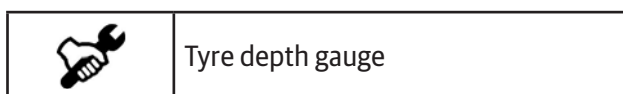

Fig. 6.8.43



Tyre depth gauge

- Check noise and play on bearing LH and RH.

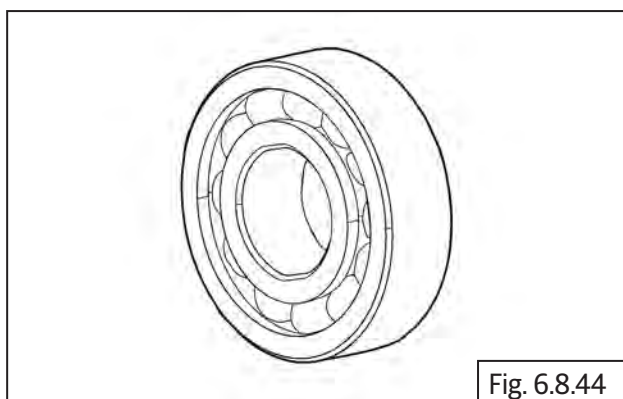

Fig. 6.8.44

- Check and replace wheel spacer if it has excess wear-out.

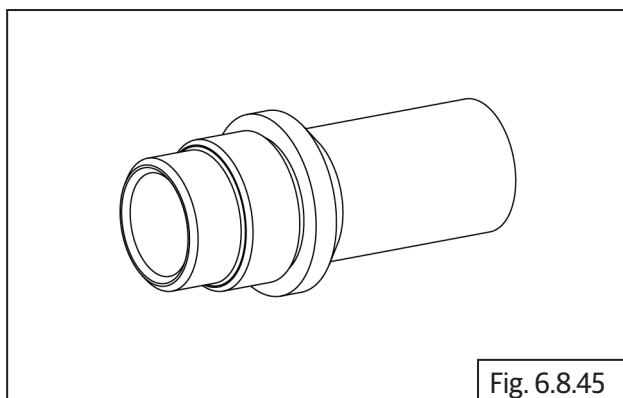

Fig. 6.8.45

- Check if wheel hub assembly is cracked or damaged and replace.
- Check and replace wheel hub bearing seated portion if there is any scoring.

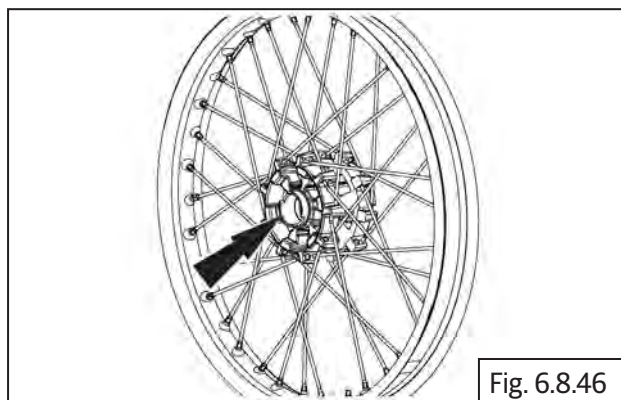

Fig. 6.8.46

- Inspect wheel rim run out / face out and replace if out of specifications.

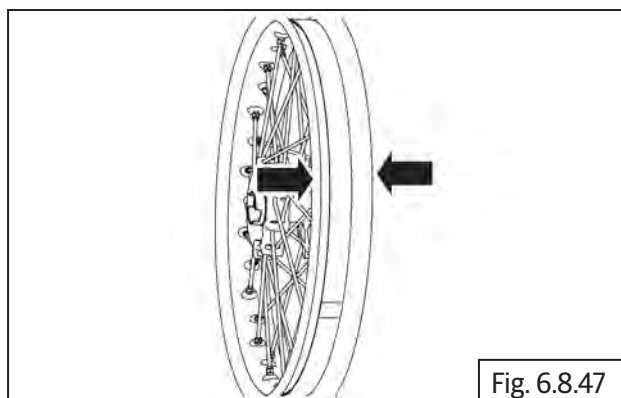

Fig. 6.8.47

Service limit: 1 mm

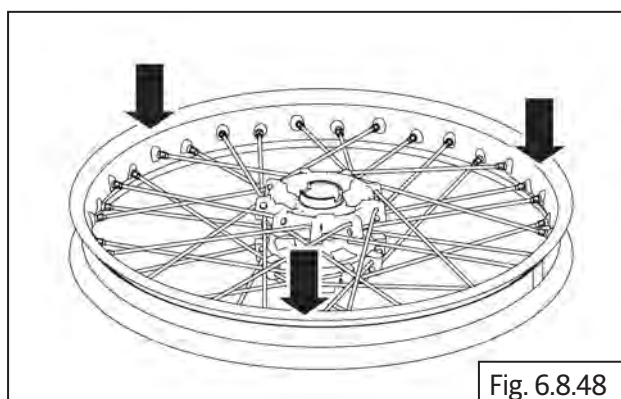

Fig. 6.8.48

- Inspect for rust, deep scoring, any foreign materials, burn marks crack in the mounting location of brake disc.
- Inspect brake disc thickness and run-out. Measure depth at points where scoring is found on the discs and replace if there is excess wear.
- Also measure thickness at the points indicated in the illustration and replace disc if out of specifications.

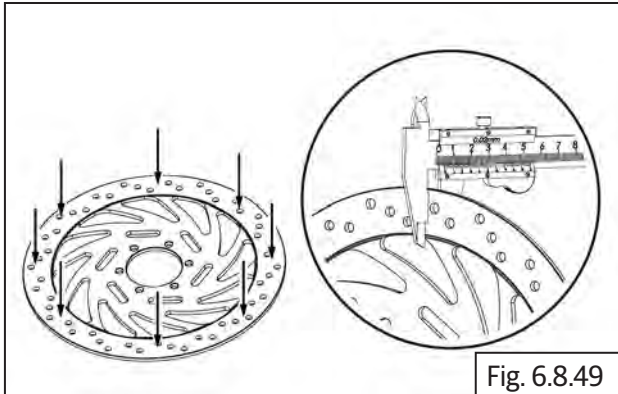

Fig. 6.8.49



Service limit:	0.8 mm
----------------	--------

- Place brake disc rotor on a flat surface and inspect warpage. Replace if it is out of specifications.

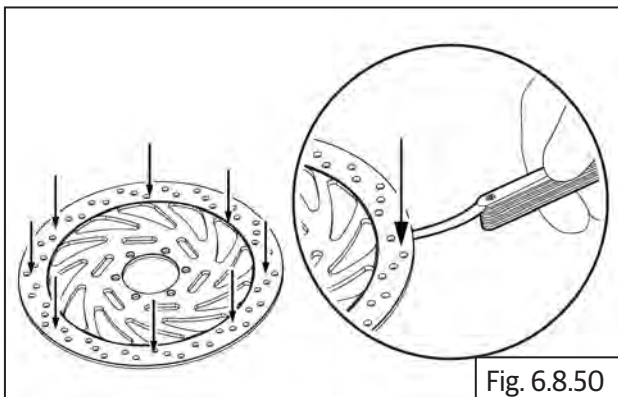
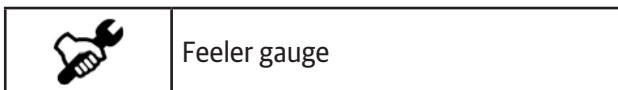

Fig. 6.8.50



Standard:	0.00mm
Service limit:	0.10mm

- Inspect and replace toner wheel plate if there are any damages or bends.

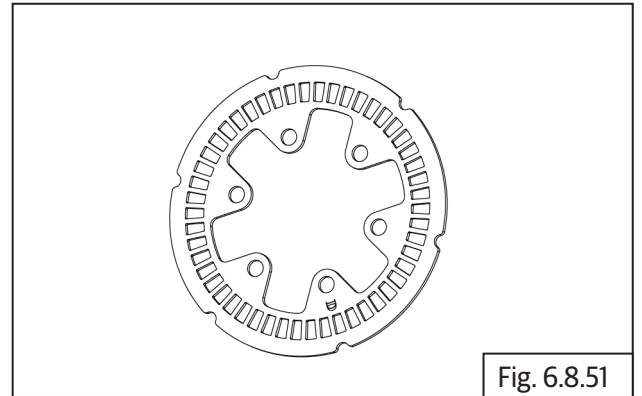

Fig. 6.8.51

- After assembly of brake disc **(a)** into front wheel, insert spindle into rim, fix on wheel balance frame **(c)** and rotate rim to check the disc run-out with dial gauge **(b)**. Ensure run-out is within specified service limits.

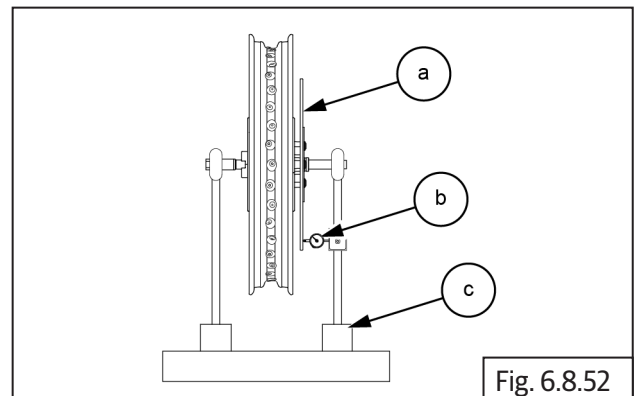

Fig. 6.8.52

Service limit:	0.10 mm
----------------	---------

NOTE

- Run-out of brake disc should be checked only when brake disc is assembled on wheel hub.

6.8.6. Rear Wheel and Brake Disc

- Inspect tyre condition and wheel rim for any damages or bends and replace if doesn't meet the specifications.

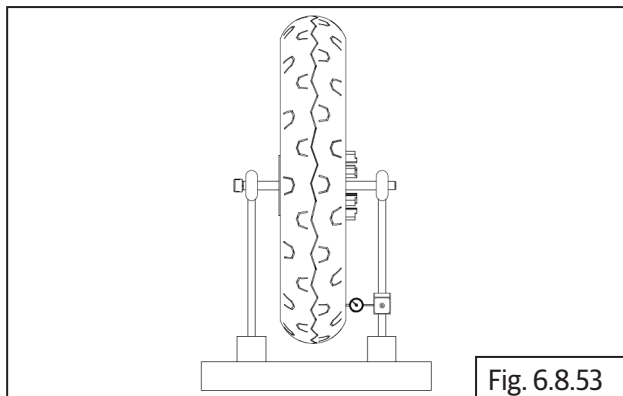

Fig. 6.8.53

- Inspect and replace spindle (a) if it has excess wear, rust or bends.

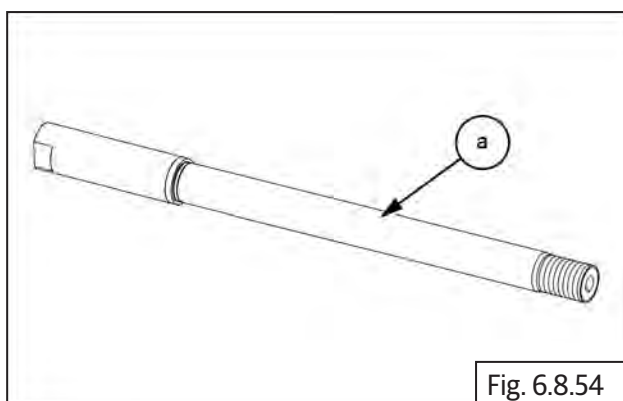

Fig. 6.8.54

- Check noise and play on bearing LH and RH. Replace if necessary.

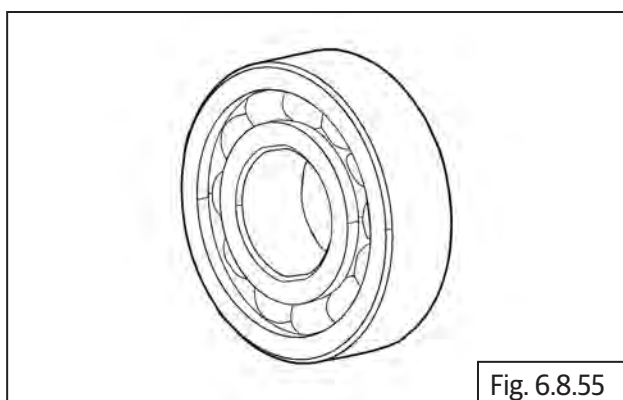

Fig. 6.8.55

- Check and replace spacer if it has excess wear-out.

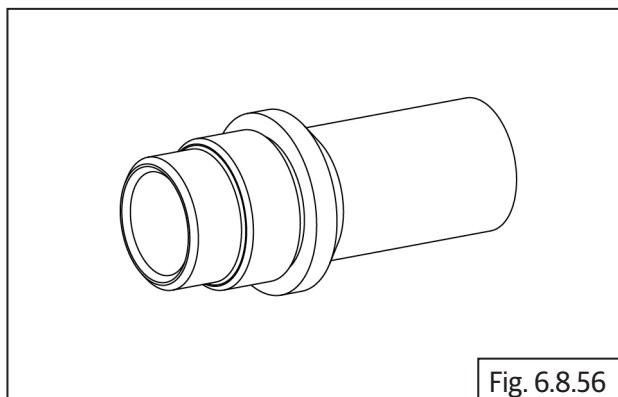

Fig. 6.8.56

- Inspect ABS toner wheel (a) for any bends or damages.
- Place ABS toner wheel on a flat surface and check warpage. Replace if out of specifications.

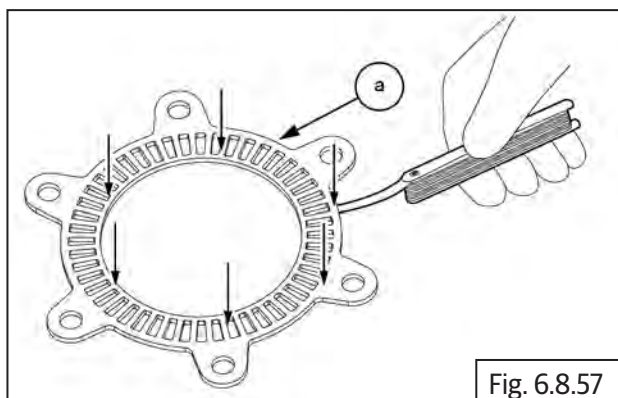

Fig. 6.8.57



Feeler gauge

Standard:	0.00 mm
Service limit:	0.10 mm

- Inspect for rust, deep scoring, any foreign materials, burn marks crack in the mounting location of brake disc.
- Inspect brake disc thickness and run-out. Measure depth at points where scoring is found on the discs and replace if there is excess wear.

- Also measure thickness at the points indicated in the illustration and replace disc **(a)** if out of specifications.

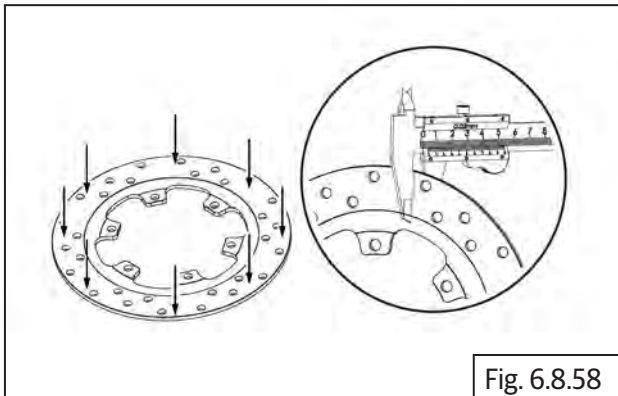

Service limit:	0.8 mm
----------------	--------

- Place brake disc rear on a flat surface and check warpage. Replace if out of specifications.

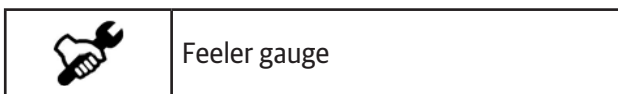
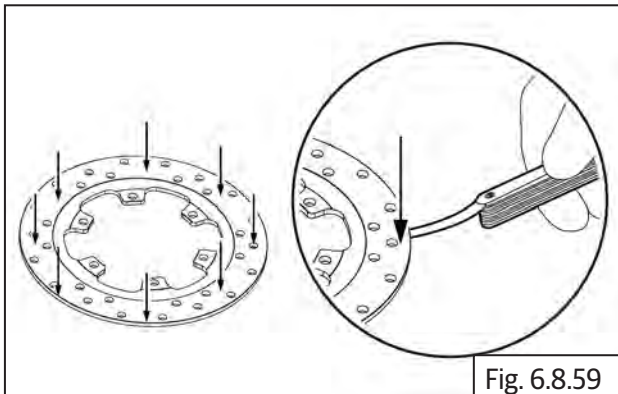

Standard:	0.00 mm
Service limit:	0.10 mm

- Inspect wheel hub assembly for any cracks or damages. Replace if out of specifications.

- Inspect if hub bearing seating portion has scoring. Replace if out of specifications.

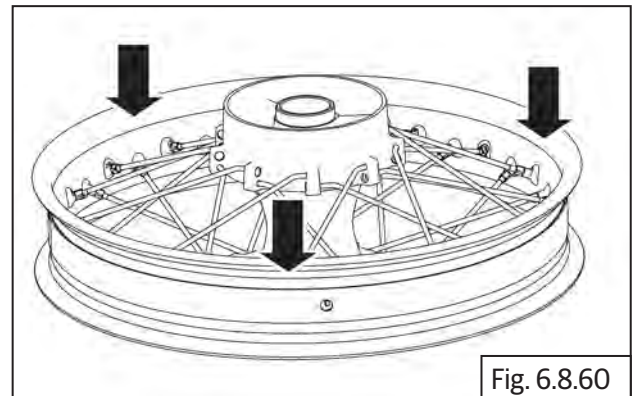

- After assembly of brake disc **(a)** into front wheel, insert spindle into rim, fix on wheel balance frame **(b)** and rotate rim to check the disc run-out with dial gauge **(c)**. Ensure run-out is within specified limits.

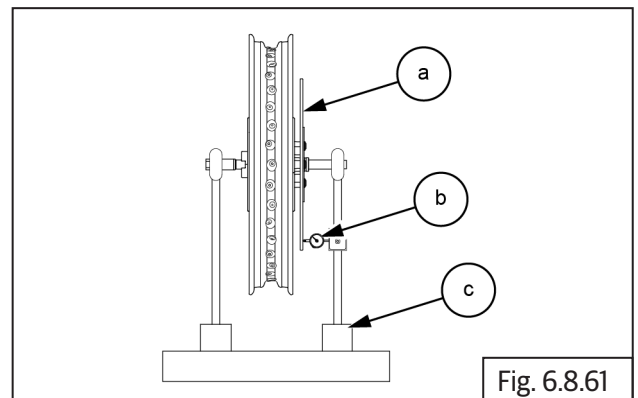

! CAUTION
Run-out of brake disc should be checked only when brake disc is assembled on wheel hub.

- Check rear wheel hub cushion rubbers for any wear-out or damages.

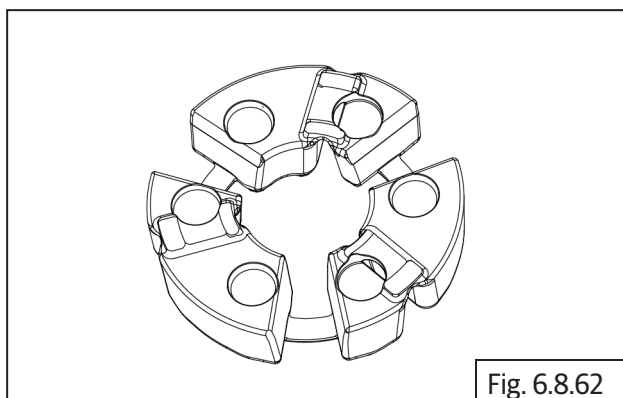

Fig. 6.8.62

- Check tyres for any uneven wear out and the sipes on the center of the tyre is above the TWI index.

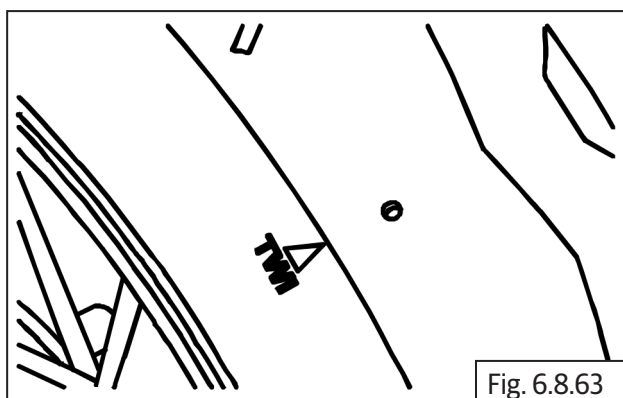
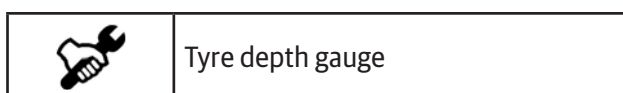

Fig. 6.8.63



Tyre depth gauge

Assembly

6.8.7. Tyre Assembly On Wheel Rim

- Ensure the tyre is assembled on the wheel rim with the arrow on the tyre side wall is facing towards the front.
- Inflate tyre to the recommended pressure and ensure the tyre is evenly seated in the rim on both LH and RH sides.

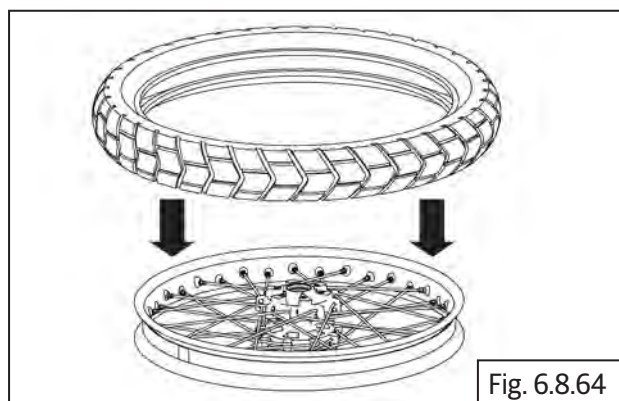

Fig. 6.8.64

6.8.8. Rear Wheel and Brake Disc

- Locate bearing LH (a) into rear wheel hub LH (b). Gently tap on the bearing and ensure it is seated properly on the hub.

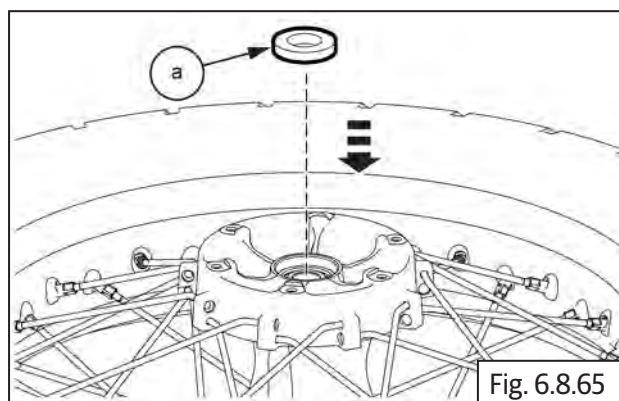

Fig. 6.8.65



Mallet

- Assemble spacer **(a)** into rear wheel hub RH. Ensure it is properly seated on the bearing surface.

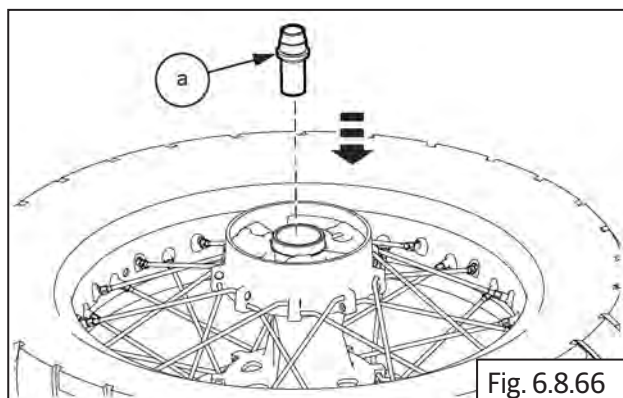

Fig. 6.8.66

- Assemble ABS toner wheel **(a)** into rear brake disc on rear wheel RH.

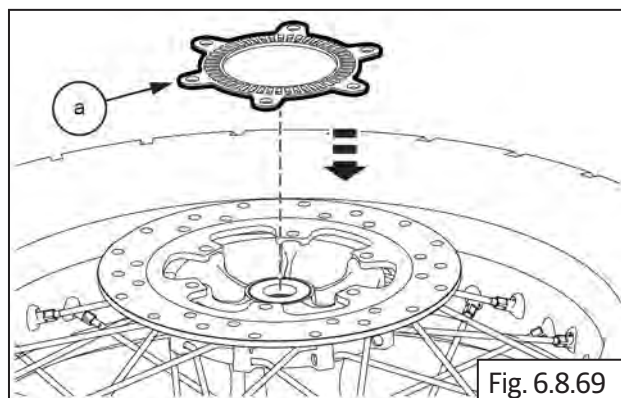

Fig. 6.8.69

- Locate bearing RH **(a)** into rear wheel hub RH. Gently tap on the bearing and ensure it is seated properly on the hub.

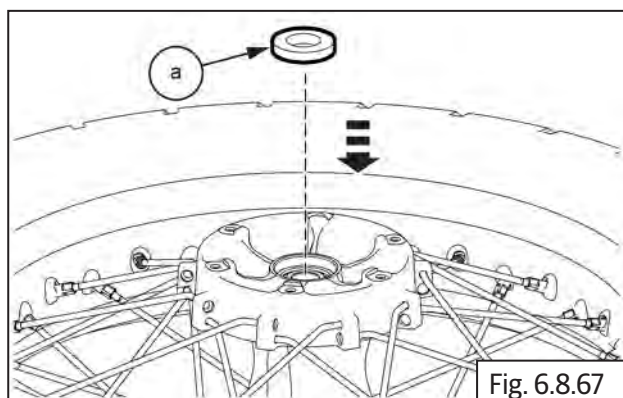

Fig. 6.8.67

- Use recommended sealant on the screws and locate and tighten 6 Nos. Hex head button socket screws **(M6) (a)** into rear wheel disc hub RH.

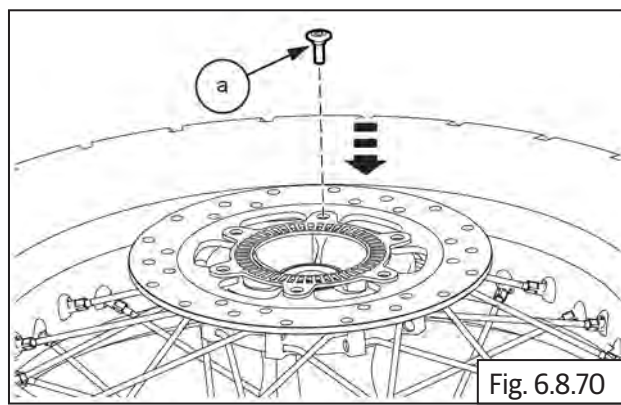

Fig. 6.8.70

- Assemble rear brake disc **(a)** into rear wheel hub RH.

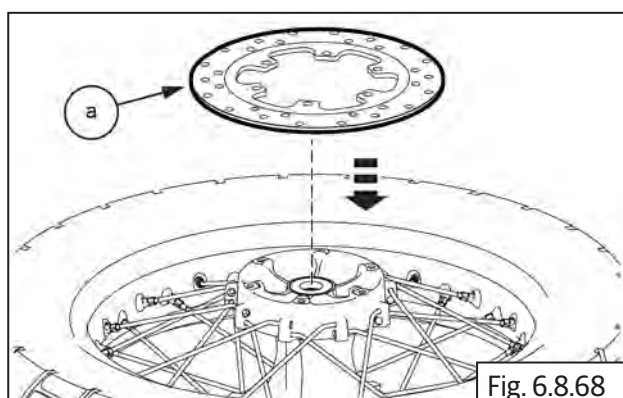

Fig. 6.8.68

	5 mm Allen socket with Ratchet
Torque	21-29 N-m/2.1-2.9 kgf-m

NOTE

- Apply Loctite 243 on the threads of the bolt before installation.

- Clean cushion rubbers seating area and insert 4 Nos. cushion rubbers **(a)** into rear wheel hub LH and gently tap with mallet .

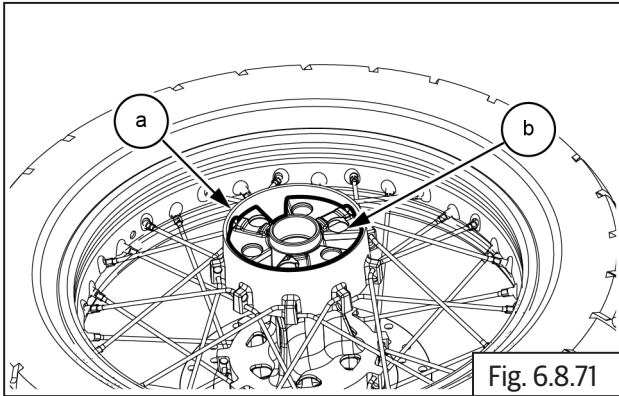

NOTE

- Always use new cushion rubbers as they are for one time usage only.

- Locate bearing **(a)** into sprocket carrier **(b)**. Ensure it is properly seated on the slot.

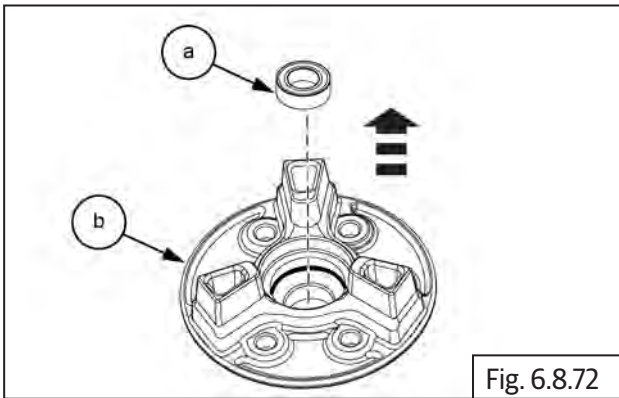

- Assemble grease seal **(a)** into sprocket carrier **(b)**.

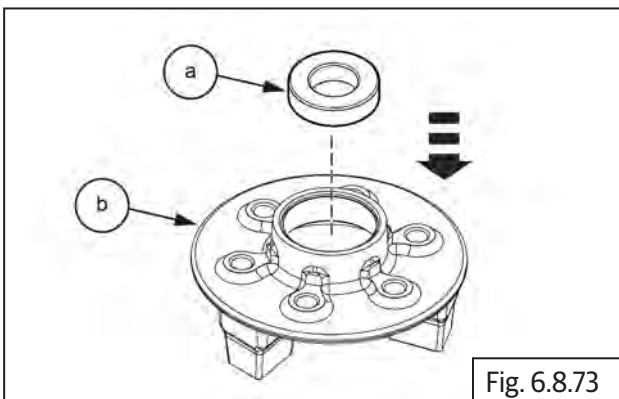

- Locate and gently tap the spacer **(a)** into sprocket carrier **(b)**.

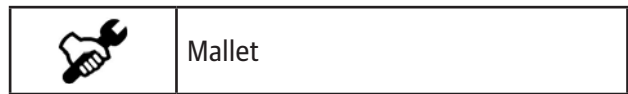
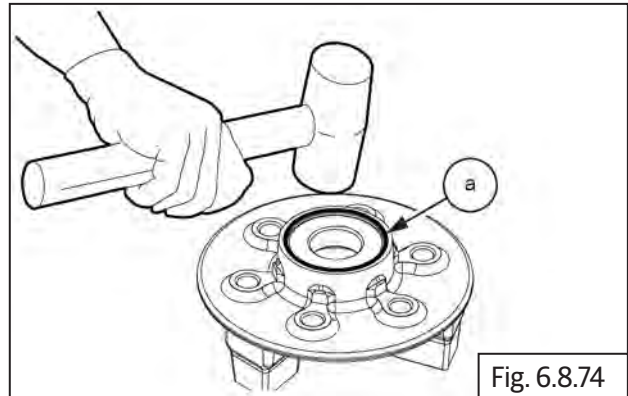

- Assemble rear sprocket carrier **(a)** over cushion rubbers into rear wheel hub LH **(b)**.

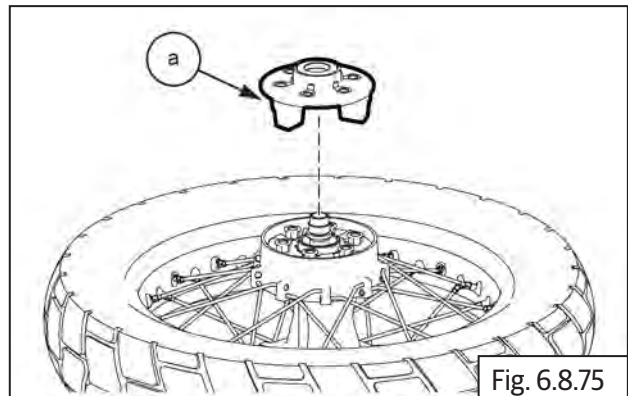

- Locate chain drive sprocket **(a)** into sprocket carrier **(b)** on rear wheel hub LH.

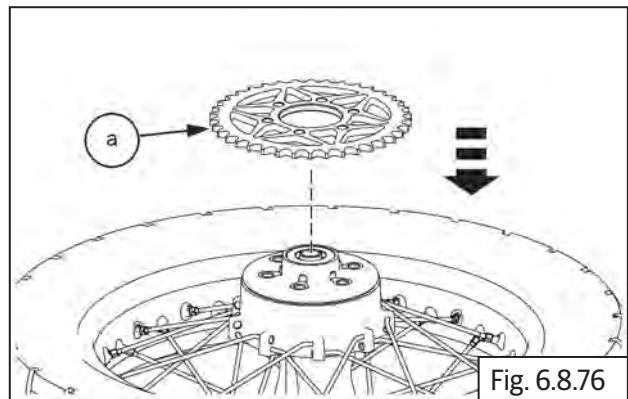

- Locate and tighten 6 Nos. Hex flanged socket head bolts (M8) (a) into carrier (b) on rear wheel LH.

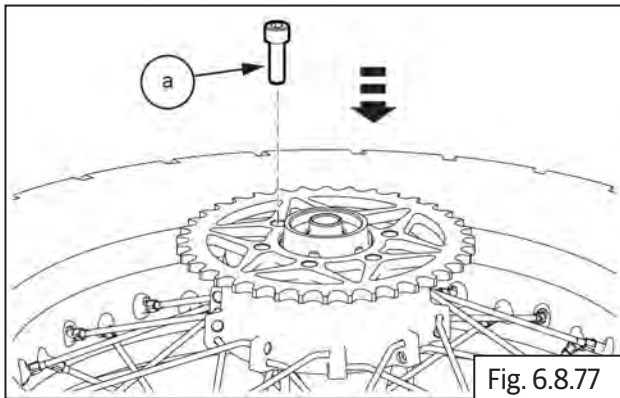

	6 mm Allen socket with Ratchet
Torque	48-52 N-m/4.8-5.2 kgf-m

NOTE

- Apply Loctite 243 on the threads of the bolt before installation.

6.8.9. Rear Wheel into Swing Arm

- Gently locate rear wheel (a) into swing arm (b).

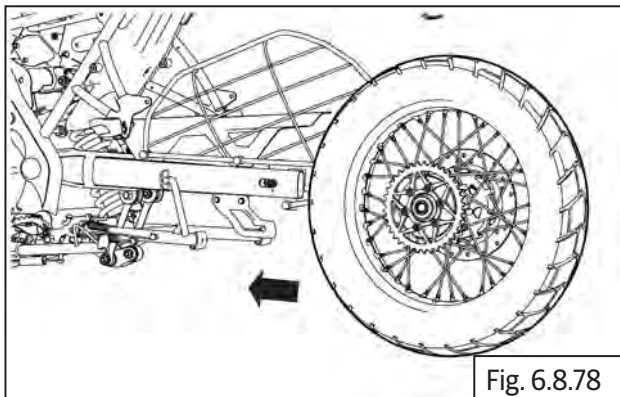

- Insert spacer (a) into rear wheel hub RH (b).

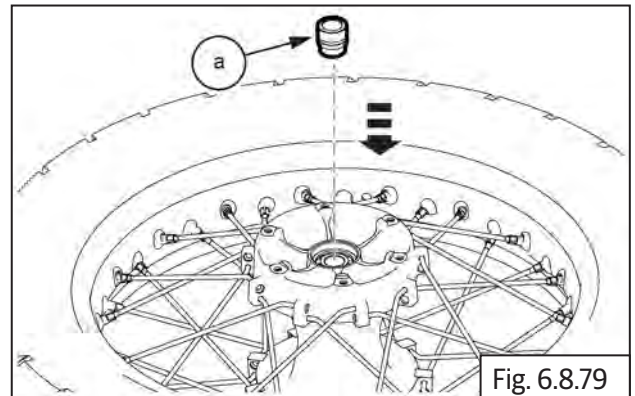

- Locate drive chain (a) onto sprocket (b) and align wheel into swing arm.

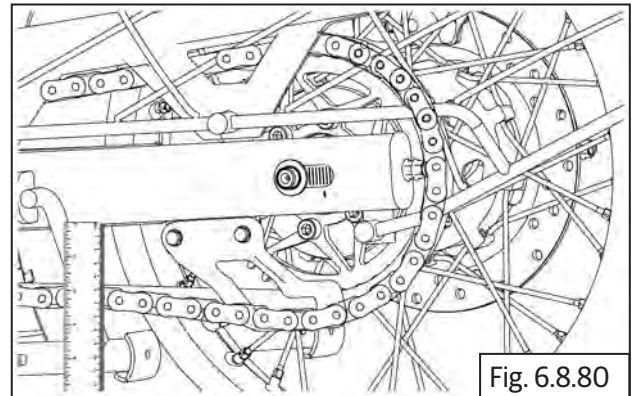

- Slide the caliper assy (a) into the swingarm.

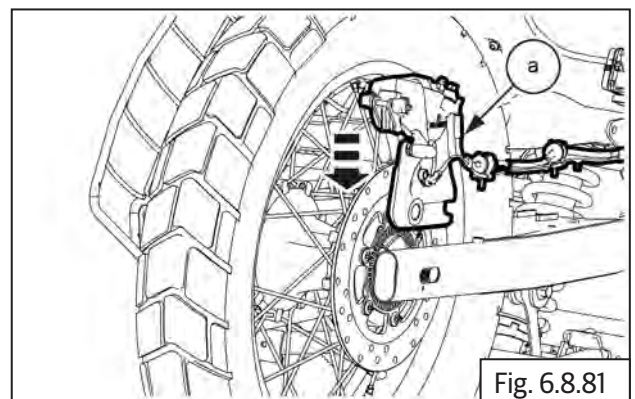

- Assemble chain adjuster assembly **(a)** into swing arm LH **(b)**.

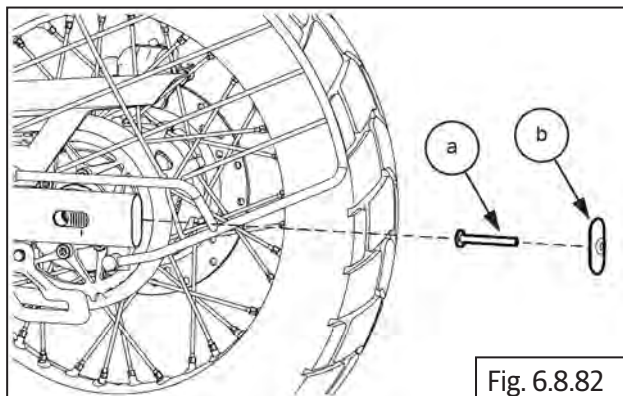

- Assemble Hex nut **(M16)** **(a)** and tighten into swing.

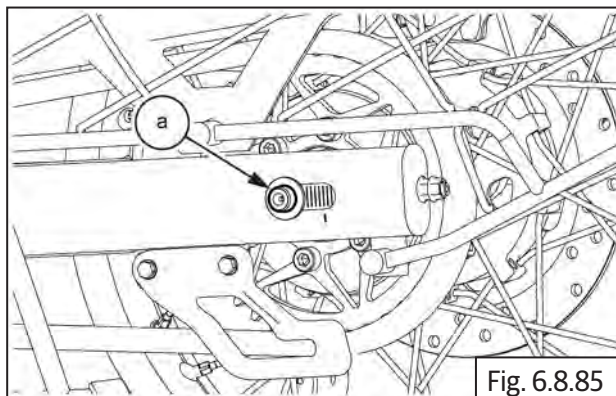

- Insert spindle **(a)** with tommy bar into rear wheel hub LH along with washer **(b)**.

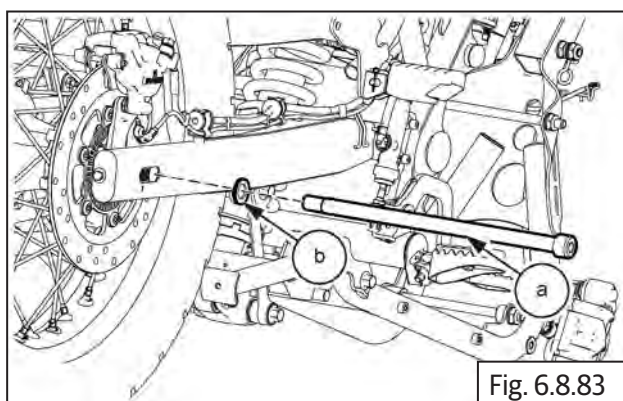

	24 mm Socket with Ratchet
Torque	63-77 N-m/6.3-7.7 kgf-m

6.8.10. Drive Chain Free Play Adjustment

- Inspect chain free play at 3 locations using a ruler. Free play for drive chain should be between 20 mm to 30 mm.

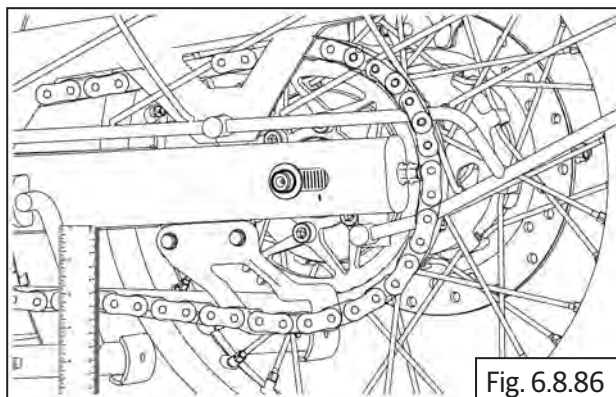

	Tommy bar
--	-----------

- Install washer **(a)** into spindle RH **(b)**.

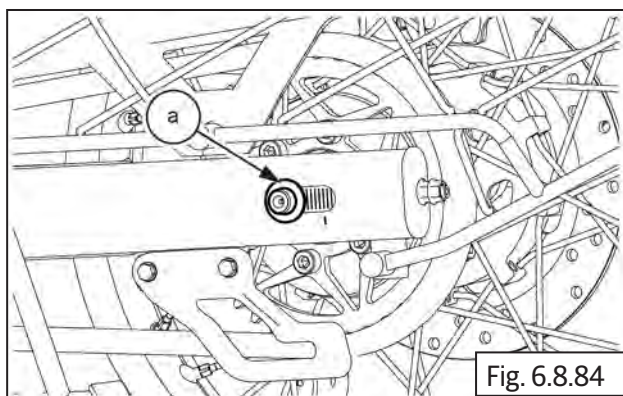

- If the free play of the drive chain is not between 20 mm to 30 mm then hold spindle **(a)** on LH using a tommy bar and loosen **(M16) (b)** axle nut on RH.

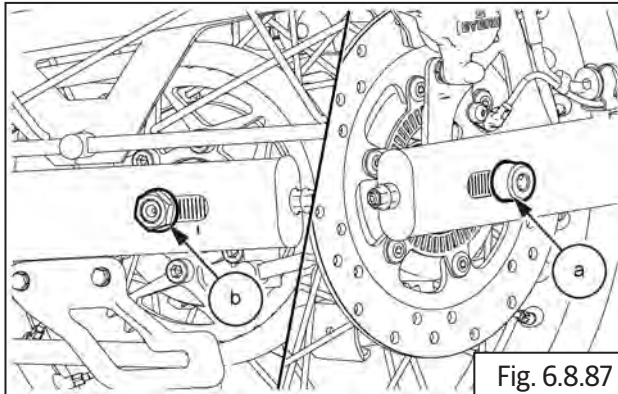

Fig. 6.8.87



24 mm Ring spanner

- To reduce free play loosen the lock nut **(M8) (a)** in anti clockwise and tighten the adjuster nut **(M8) (b)** in clockwise both LH and RH.

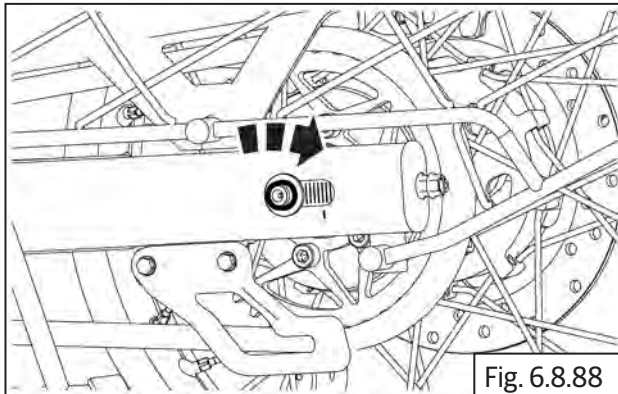

Fig. 6.8.88



5 mm Allen Key and Tommy bar

- Ensure the lines are matched with the lines punched in swing arm on both LH & RH side for proper wheel alignment.

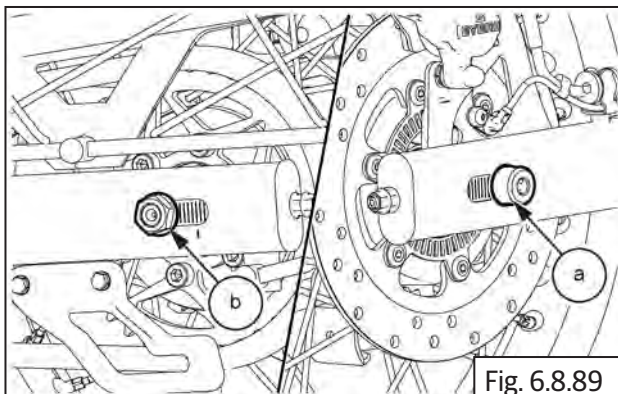

Fig. 6.8.89

- Now measure the drive chain free play using ruler and it should be between 20 mm to 30 mm.

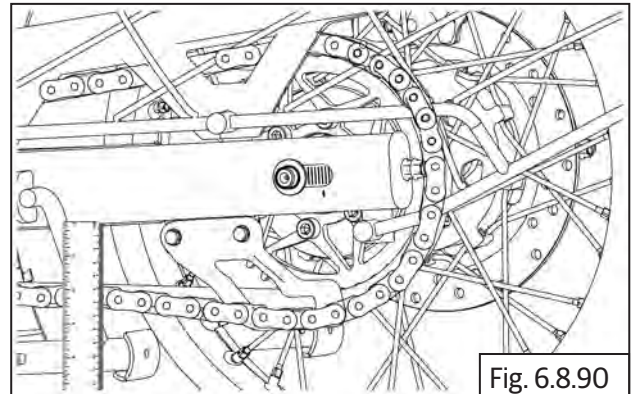

Fig. 6.8.90

CAUTION

Chain slackness beyond 40 mm will lead to chain slippage or breakage.

- Once chain free play is verified, hold spindle LH with tommy bar **(a)** and tighten the wheel axle nut **(M16) (b)**.

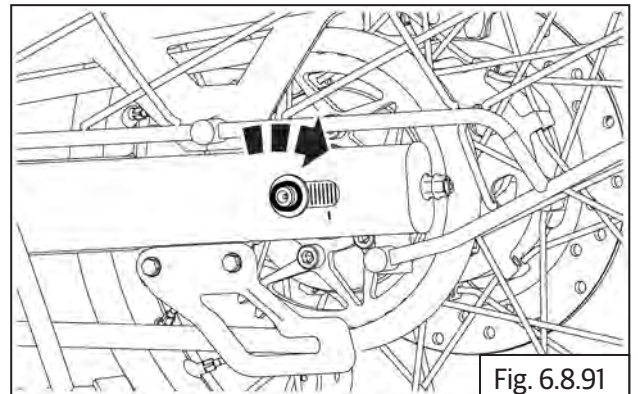

Fig. 6.8.91



24 mm Ring spanner and Tommy bar

Torque

63-77 N-m/6.3-7.7 kgf-m

6.8.11. Tyre Assembly on Wheel Rim

- Ensure the tyre is assembled on the wheel rim with the arrow on the tyre side wall is facing towards the front.
- Inflate tyre to the recommended pressure and ensure the tyre is evenly seated in the rim on both LH and RH sides.

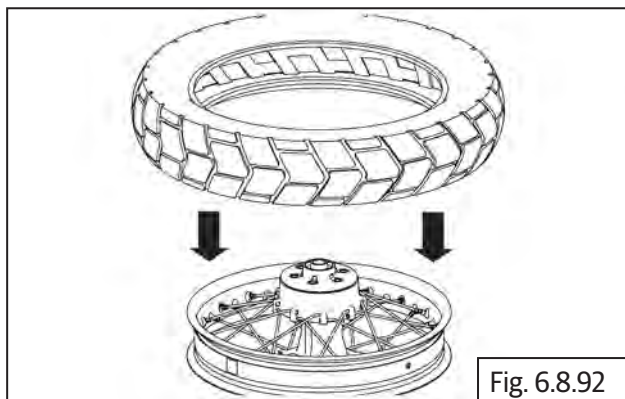

6.8.12. Front Wheel and Front Brake Disc

- Locate front brake disc **(a)** on wheel hub with the disc facing up. Ensure mounting holes are correctly aligned.

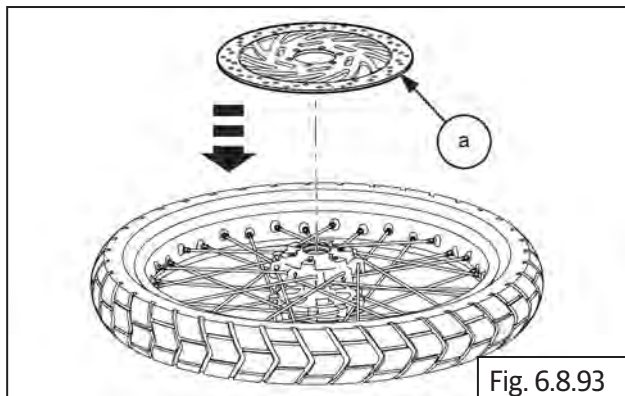

- Position toner wheel **(a)** on front disc and ensure mounting holes are correctly aligned.

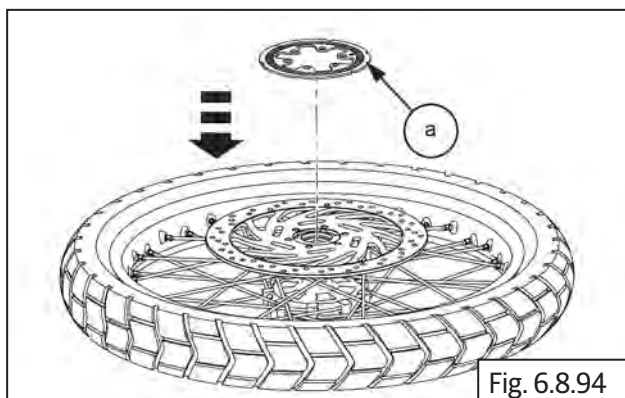

- Apply thread sealant on the 5 Nos Hex socket head bolts **(M6) (a)** and allow it to dry for a few minutes.
- Locate the bolts on the mounting holes and tighten toner ring and brake disc to the wheel hub in crisscross pattern to specified torque.

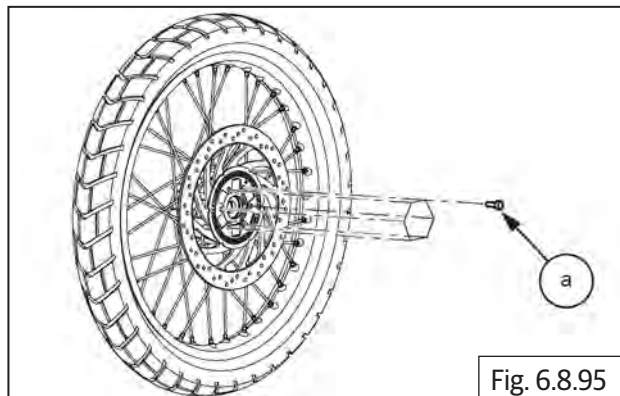

	5 mm Allen socket with Ratchet
Torque	21-29 N-m/2.1-2.9 kgf-m

- Insert bearing **(a)** into front wheel hub RH **(b)**.

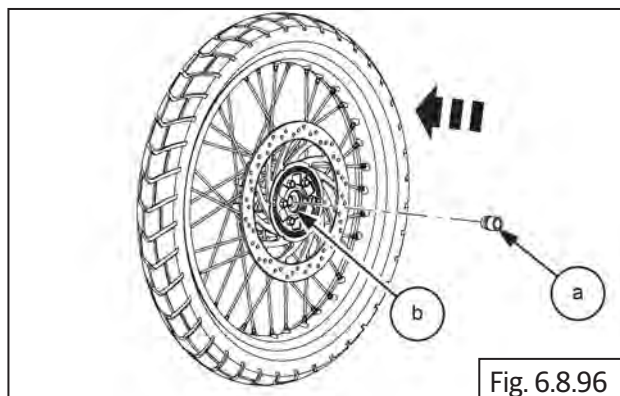

- Insert bearing spacer **(a)** from LH side of front hub **(b)**.

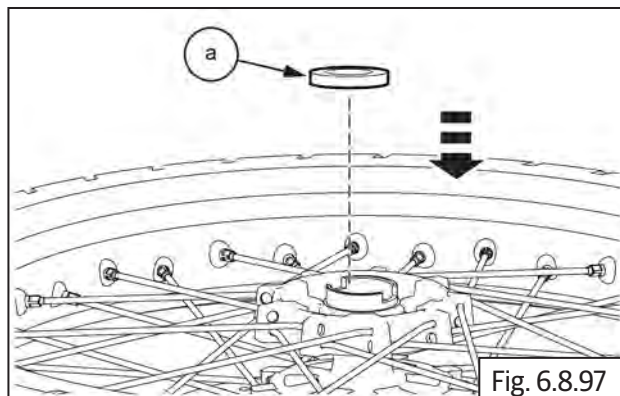

- Insert bearing **(a)** into wheel hub LH **(b)**.

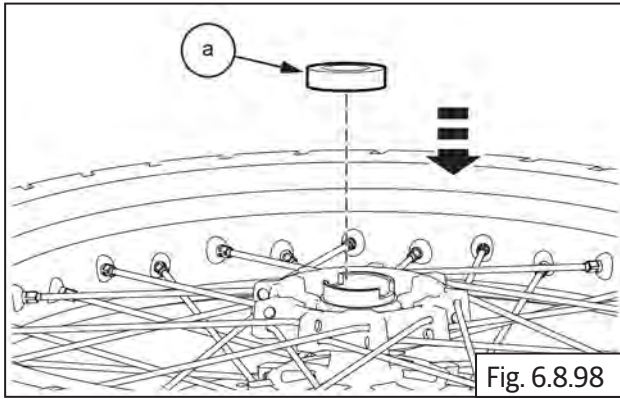

Fig. 6.8.98

- Install grease seal **(a)** into wheel hub LH with seal installer.

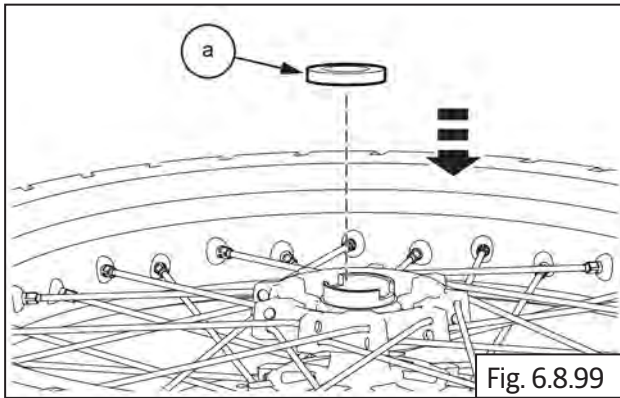

Fig. 6.8.99



Seal installer

6.8.13. Front Wheel into Front Fork Assembly

- Carefully align front wheel **(a)** into front fork assembly **(b)**.

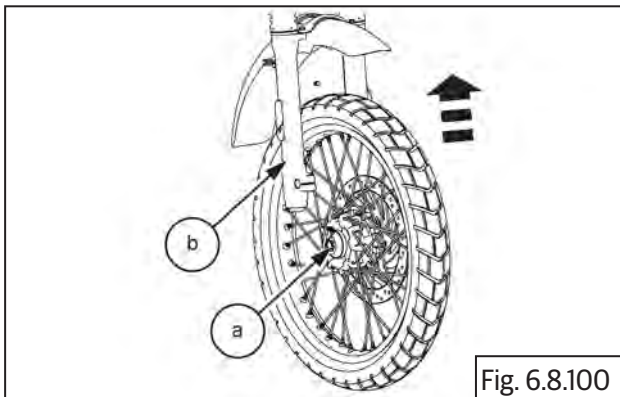

Fig. 6.8.100

- Insert spacer **(a)** in to wheel hub **(b)** from LH.

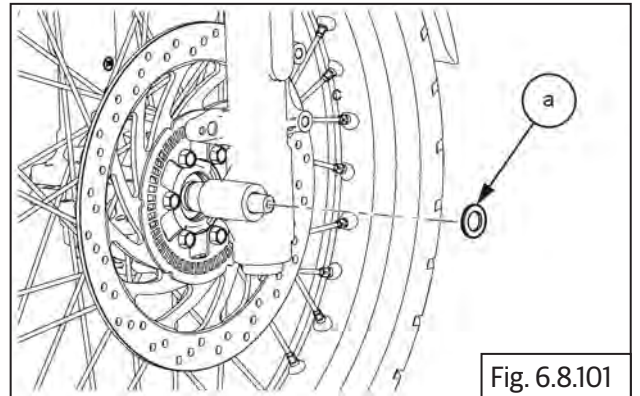

Fig. 6.8.101

- Gently align wheel speed sensor assembly **(a)** between wheel hub **(b)** and the front fork assembly **(c)**.

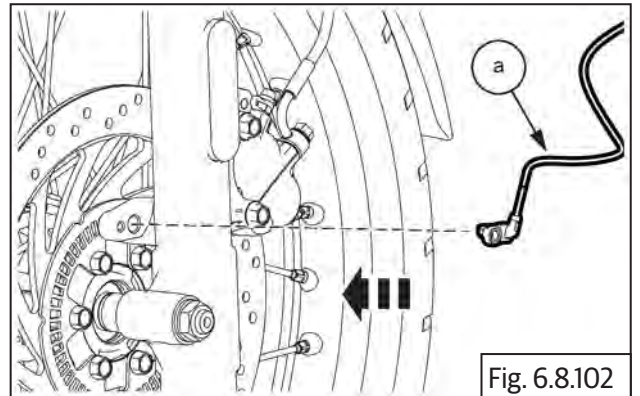

Fig. 6.8.102

- Insert spindle **(a)** into front fork assembly RH and wheel hub **(b)**.

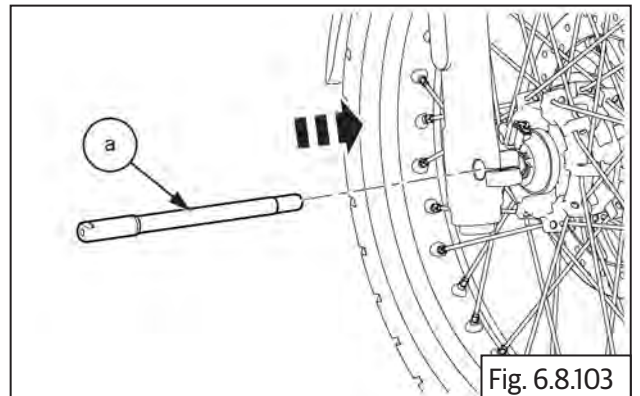

Fig. 6.8.103

- Insert Hex nut **(M16) (a)** along with washer **(b)** into spindle bolt on LH.
- Hold spindle with Tommy bar from RH and gently tighten Hex nut **(M16) (a)**.

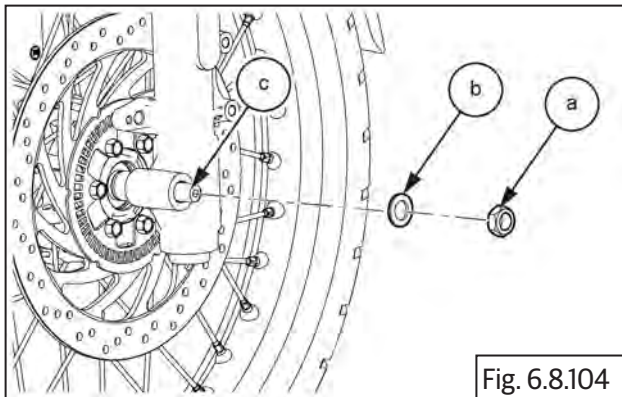



Fig. 6.8.104

	24 mm Socket with Ratchet and Tommy bar
Torque	63-77 N-m/6.3-7.7 kgf-m

- Tighten Hex socket bolt **(M6) (a)** into front fork assembly RH.

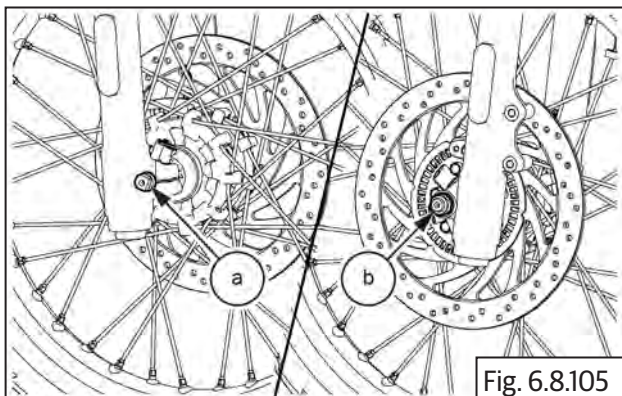



Fig. 6.8.105

	5 mm Allen Key
Torque	21-29 N-m/2.1-2.9kgf-m

Troubleshooting

Symptom	Possible Cause	Diagnosis	How To Fix	Recommended Specification
1. Tyres Related				
Centre Threads Wear-Out Is High/ Poor Traction/ Unstable Riding	Tyre pressure is more than recommended.	Front and rear tyre pressure is over inflated.	Ensure correct tyre pressures.	Front tyre: 32 psi/2.2 kg/cm ² . Rear tyre: Solo: 36 psi/2.2 kg/cm ² With Pillion: 39 psi/2.74 kg/cm ² .
Side Threads Wear-Out Is High/Side Wall Has Cracks/ Motorcycle Has Dragging/Unstable Riding	Tyre pressures is less than recommended.	Front and rear tyre pressures under inflated side walls have minute cracks.	Check inner tubes for any puncture/ leaky valve pins ensure correct tyre pressures.	Front tyre: 32 psi/2.2 kg/cm ² . Rear tyre: Solo: 36 psi/2.2 kg/cm ² . With Pillion: 39 psi/2.74 kg/cm ² .
Rear Tyre Wear-Out On One Side	Improper wheel alignment.	Rear wheel misaligned with respect to front wheel.	Check and correct wheel alignment.	
Tyre/S Wearing Out Is Uneven/ Motorcycle Is Unstable/Wobbling	Internal defect/poor quality tyre.	Tyres found to have bulges/cracks in side wall. Threads are separated from the tyre.	Replace with Royal Enfield recommended tyres.	Front tyre: 100/90-18, Pirelli Phantom Sports Comp. Rear tyre: 130/70-18, Pirelli Phantom Sports Comp.
	Tyre seating on rims is improper.	Tyre bead is uneven at the rim surface.	Remove tyre and reset correctly.	
	Wheel rims have a defect.	Wheel rims are bent/ have excessive run out.	Remove tyre and carry out proper wheel truing.	
	Rims have excessive side play.	Wheel bearings worn-out/excessive play.	Remove and replace wheel bearings.	

Symptom	Possible Cause	Diagnosis	How To Fix	Recommended Specification
2. Wheel Rims Related				
Motorcycle Is Unstable/Wobbling	Tyre seating on rims is improper	Tyre bead is uneven at the rim surface	Remove tyre and reset correctly	
	Wheel rims are out of trueness	Wheel rims are bent/ have excessive run out	Remove tyre and true the wheel rim correctly	
	Wheel rims have a crack/heavy damage	Wheel rims are cracked/damaged due to impact	Replace wheel rims	
3. Others				
Motorcycle Is Unstable/Wobbling	Wheels have excessive axial/side play	Wheel bearings are worn-out	Remove bearing and replace	
	Hubs Front/rear are cracked/damaged	Wheel Hubs are damaged due to impact	Replace hubs	

NOTE

- The trouble shooting given in this section is only related to the issues with wheels. For complaints related to other issues such as poor suspension action/handling/unstable ride please refer to suspension ([section 6.9](#)).

SUSPENSION

Suspension

CONTENTS	PAGE
6.9 Suspension	238
Dismantling	238
6.9.1. Front Fork LH and RH Removal from Motorcycle.....	238
6.9.2. Front Fork Sub Assembly LH and RH.....	239
6.9.3. Steering Stem Assembly from Frame Head Tube	242
6.9.5. Shock absorber	244
6.9.6. Swingarm.....	245
Inspection	247
6.9.7. Front Fork Leg	247
6.9.8. Front Fork Air Gap Setting	248
6.9.9. Steering Stem	249
6.9.10. Shock absorber.....	249
6.9.11. Swingarm.....	249
6.9.12. Top Yoke	250
Assembly	250
6.9.13. Swingarm.....	250
6.9.14. Shock Absorber	251
6.9.15. Steering Stem Assembly into Frame Head Tube.....	252
6.9.17. Steering Stem on Frame Head Tube.....	252
6.9.19. Front Fork Sub Assembly LH and RH.....	253
6.9.20. Front Fork LH and RH Assembly on Motorcycle.....	256
6.9.21. Steering Stem Play Adjustment.....	258
Troubleshooting	260

6.9 Suspension

Dismantling

6.9.1. Front Fork LH and RH Removal from Motorcycle

⚠ CAUTION

Ensure the motorcycle is upright on a firm and flat surface.

- Locate a scissor jack **(a)** under cradle frame **(b)** and lift motorcycle such that the front wheel is off the ground by minimum 6 inches (or 15 cm).

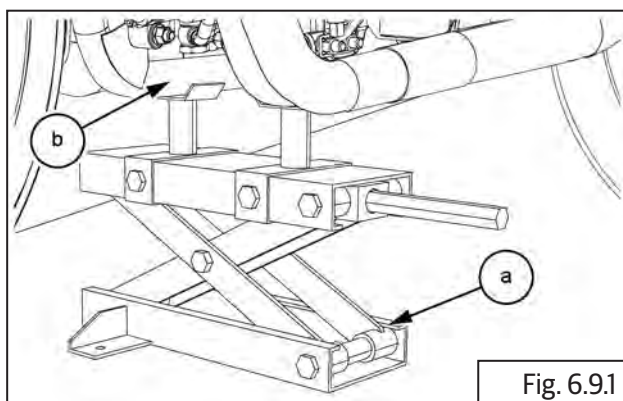

- Ensure ignition and stop switch are in off position.
- Remove the following parts:
 - Front wheel ([section 6.8.1](#)).
 - Release brake hose and wheel speed sensor wires from the clips ([section 9.3.2](#)).
 - Wheel caliper from fork end LH ([section 9.1.2](#)). Support caliper suitably.
 - Wheel speed sensor from the fork end LH ([section 9.3.2](#)). Support wheel speed sensor suitably.
 - Front mudguard ([section 6.6.2](#)).
 - Front number plate ([section 6.6.1](#)).
 - Headlamp assembly and housing ([section 11.1](#)).
 - Trafficators front ([section 11.1.6](#)).

- Loosen fork cap bolts **(a)** just sufficiently on both LH and RH fork assemblies.

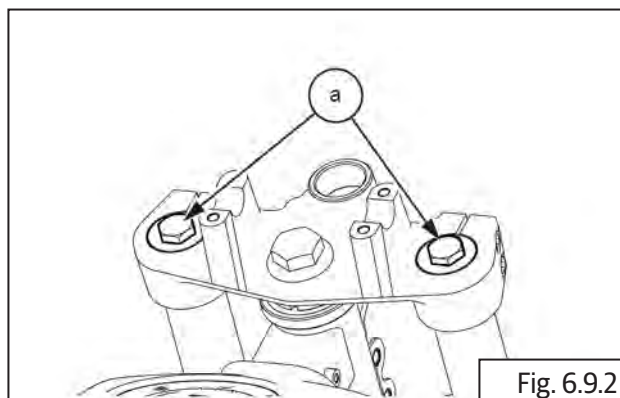

32 mm Ring spanner

- Loosen 4 Nos. Hex socket head bolts **(M8) (a)** sufficiently on LH steering stem.

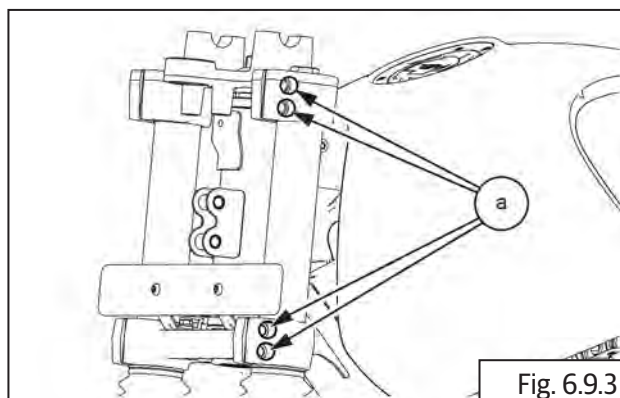

6 mm Allen socket with Ratchet

- Loosen 4 Nos. allen head bolts **(a)** sufficiently on RH side.

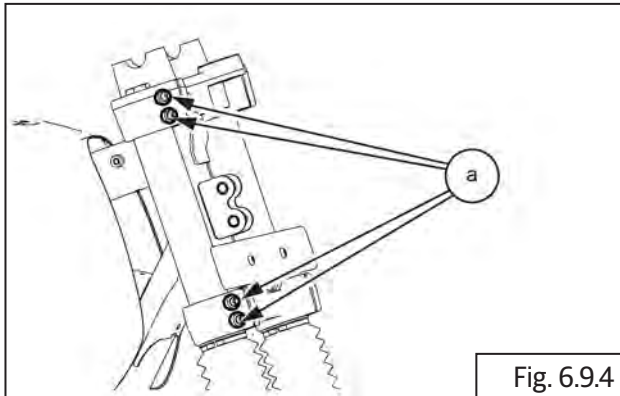

- Gently rotate and pull out fork assembly LH **(a)** downwards to remove from top yoke and steering stem **(b)**.

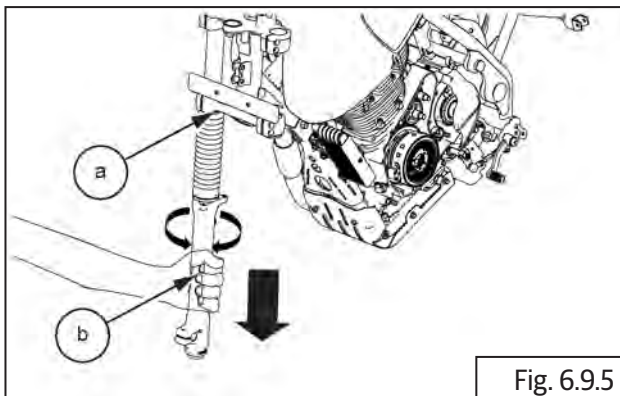

- Repeat above steps to remove the fork assembly RH **(a)**.

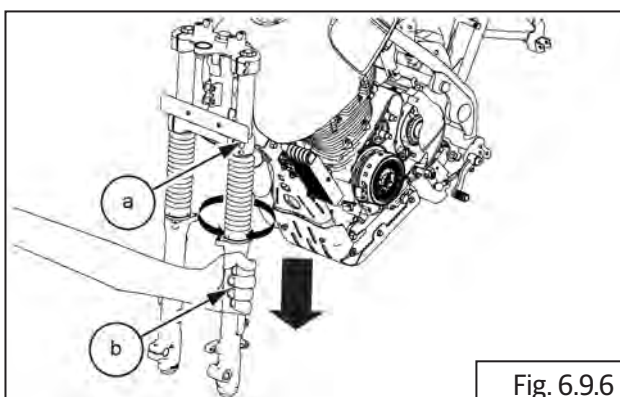

6.9.2. Front Fork Sub Assembly LH and RH



- Loosen and remove cap nut **(a)** along with O-ring from upper end of front fork leg **(b)**.

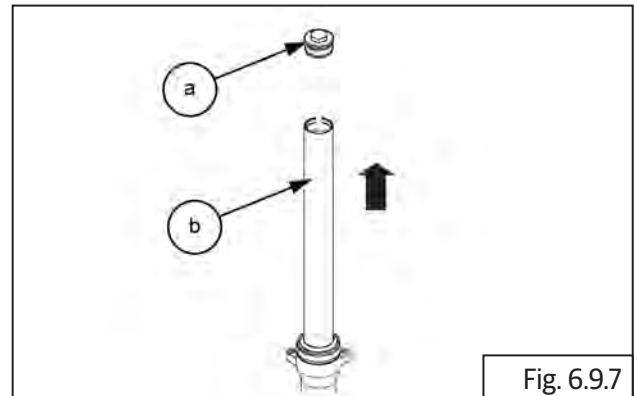

- Remove plate **(a)**.

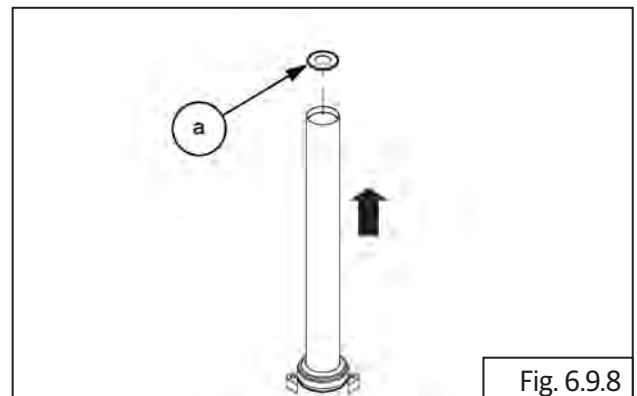

- Gently pull out the spacer tube **(a)**.

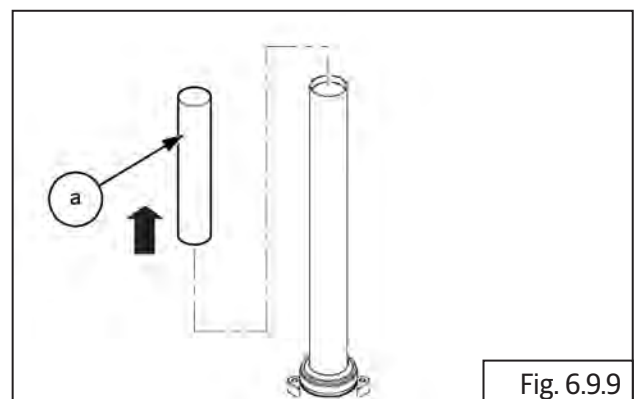

- Gently invert fork assembly **(a)** into a clean tray to collect the fork oil coming out of main tube.

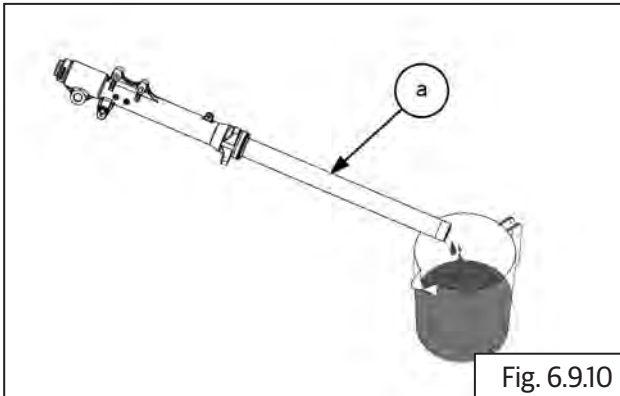

- Hold fork **(a)** inverted and pump main tube into fork end several times till oil in the fork end drains out completely.

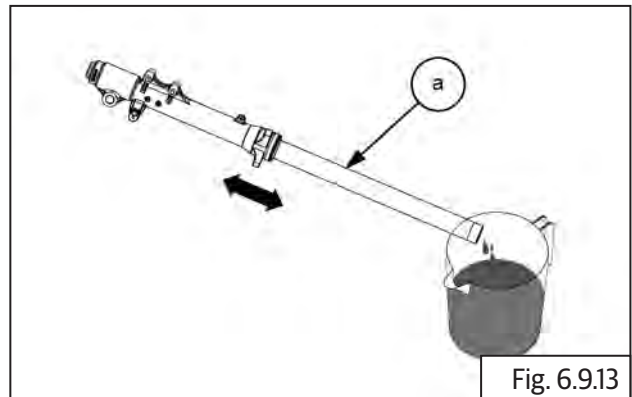

⚠ CAUTION

Support the washer and main spring to prevent them from falling out when the oil has been drained.

- Remove washer **(a)**.

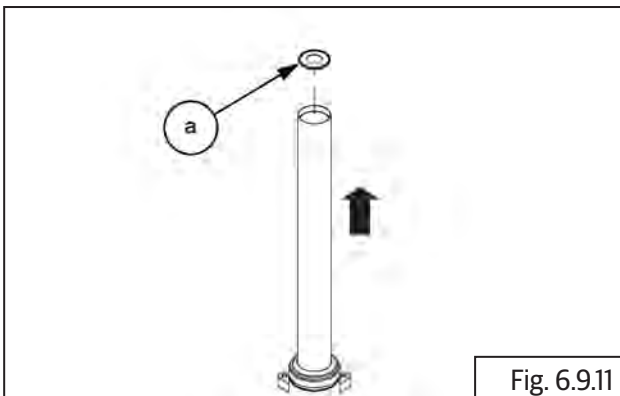

- Insert special tool **(a)** into fork main tube **(b)** to lock and hold piston head inside.

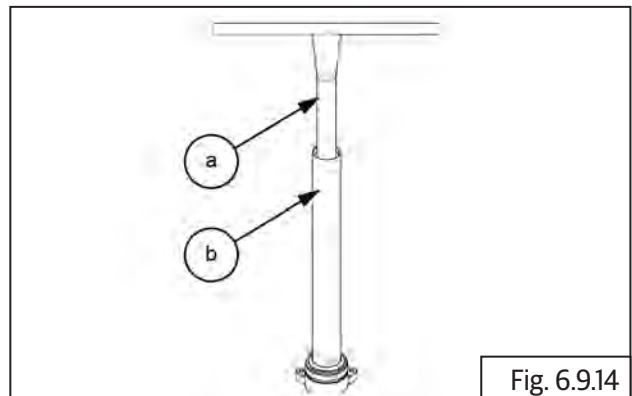

 SPL	Part No:
	Part Name: Fork damper tube holder

- Remove main spring **(a)**.

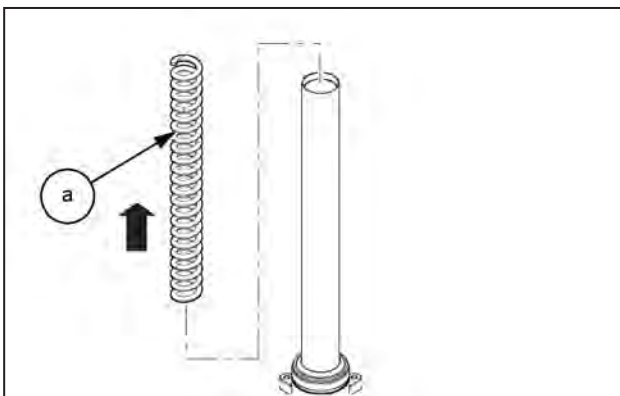

- Remove Hex socket head screw **(M6) (a)** along with washer **(b)** from fork end.

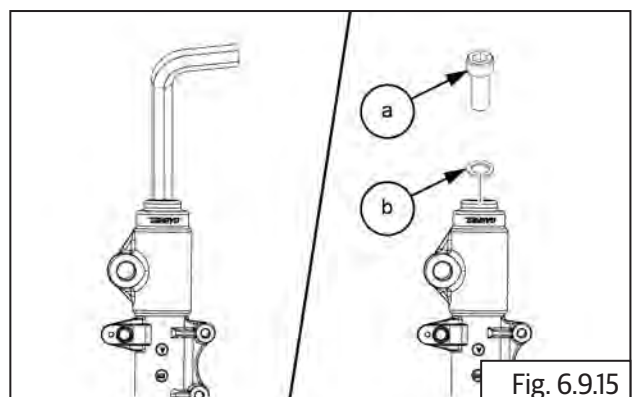



- Remove the special tool from fork main tube.
- Gently lift dust cap out of fork end **(a)** and remove completely.

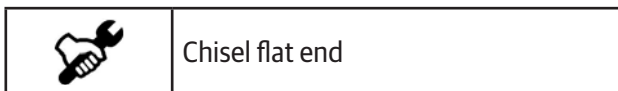
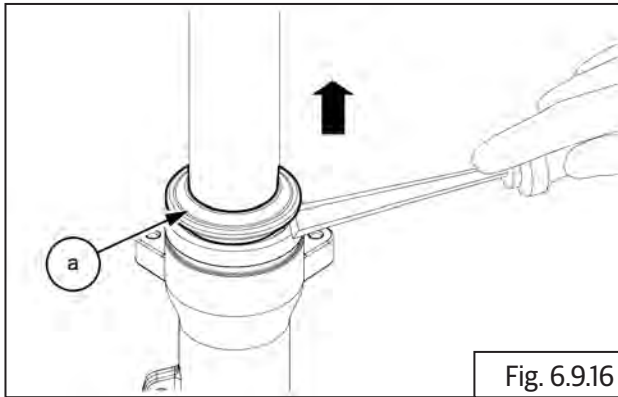

- Remove wire clip **(a)** from bottom tube.

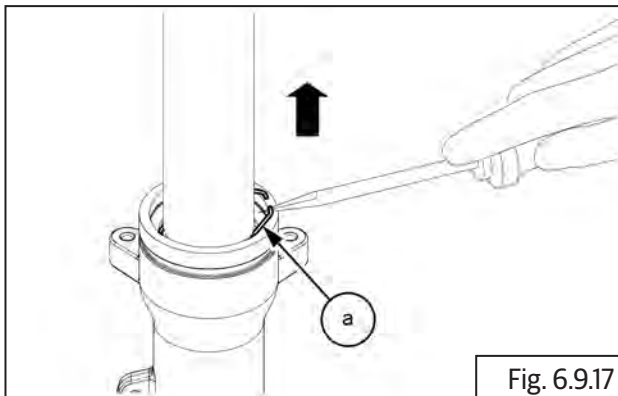

- Hold bottom tube firmly and pull out main tube sharply, to release oil seal and aluminum spacer from bottom tube.
- Pull out main tube **(a)** completely from bottom tube **(b)**.

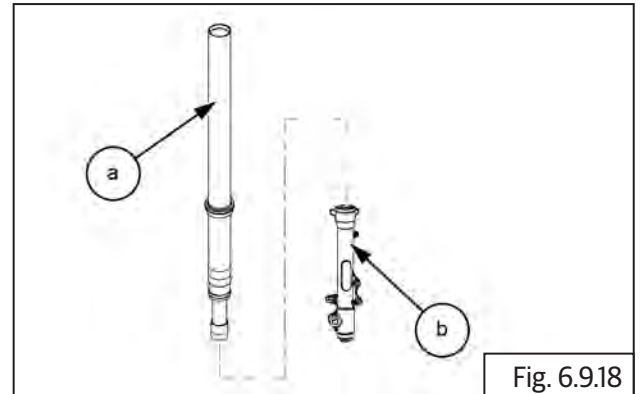

- Remove the oil seal **(a)** from main tube **(b)** from top end.

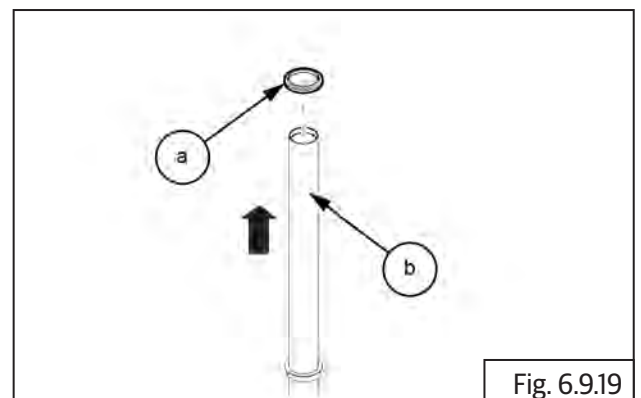

- Remove spacer **(a)** from main tube **(b)** from top.

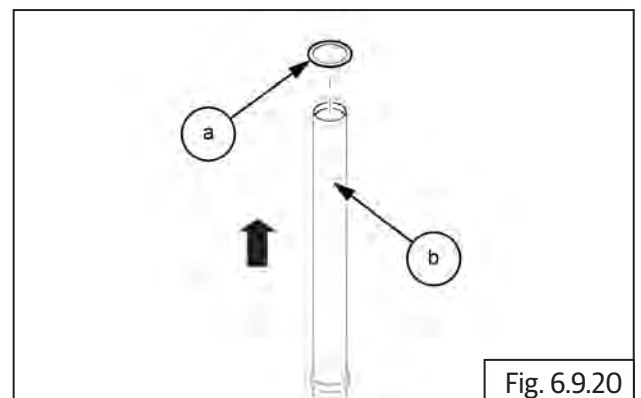

- Remove aluminum split bush **(a)** from main tube **(b)** bottom.

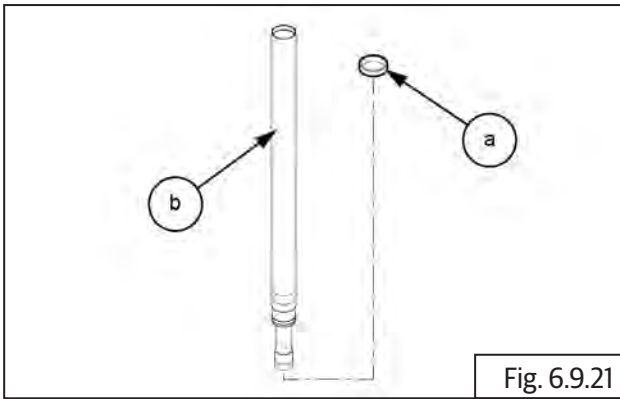

- Remove taper oil lock **(a)** from piston bottom **(b)** inside fork end.

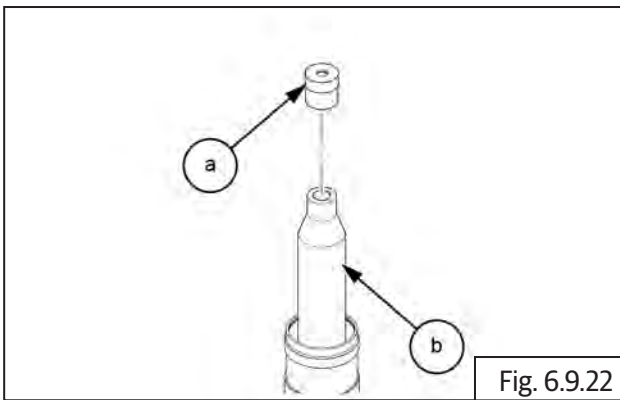

- Tilt main tube up-side down and remove piston assembly **(a)** along with damper spring from main tube **(b)** inner.

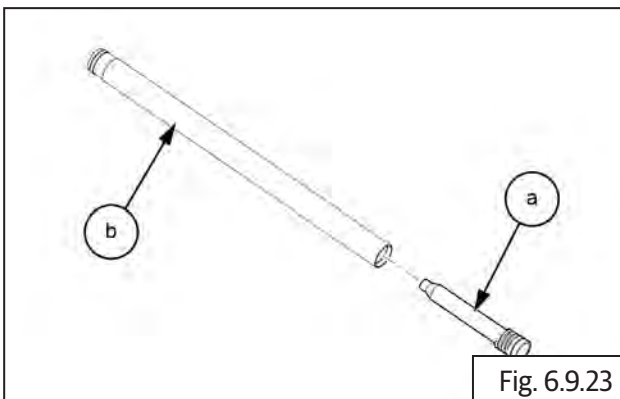

- Remove damper spring **(a)** from piston **(b)**.

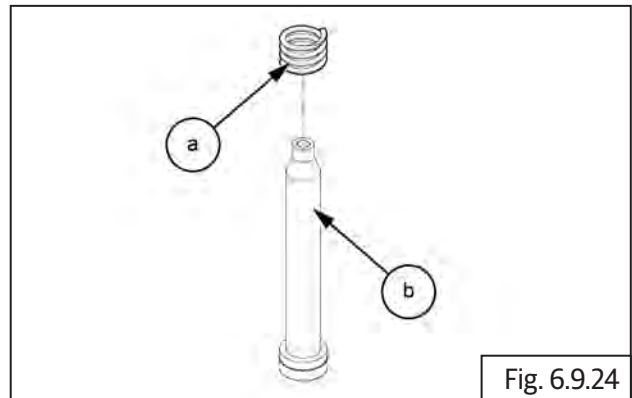

6.9.3. Steering Stem Assembly from Frame Head Tube

⚠ CAUTION

Ensure the motorcycle is upright on a firm and flat surface.

- Locate a scissor jack **(a)** under the cradle frame **(b)** and lift motorcycle such that the front wheel is off the ground by minimum 6 inches (or 15 cm).

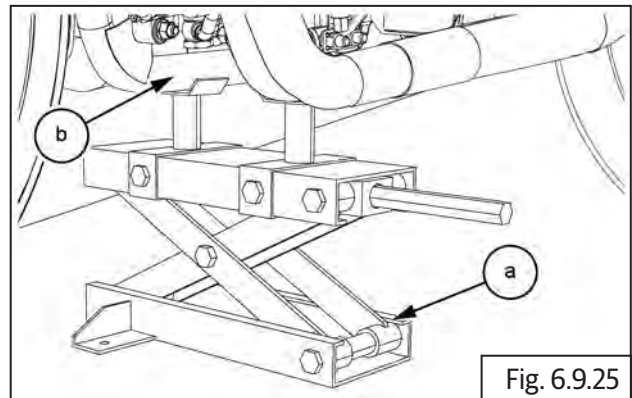

- Ensure ignition and stop switch are in off position.
- Remove the following parts:
 - Front wheel ([section 6.8.1](#)).
 - Release brake hose and wheel speed sensor wires from the clips ([section 9.3.2](#)).
 - Wheel caliper from fork end LH ([section 9.1.2](#)). Support caliper suitably.
 - Wheel speed sensor from the fork end LH ([section 9.3.2](#)). Support wheel speed sensor suitably.
 - Front mudguard ([section 6.6.2](#)).

- Front number plate ([section 6.6.1](#)).
- Headlamp assembly and housing ([section 11.1](#)).
- Trafficators ([section 11.1.6](#)).
- Fork LH and RH ([section 6.9.1](#)).
- Disconnect ignition switch connector ([section 11.1.4](#)).
- Disconnect instrument cluster wiring connector ([section 11.1.4](#)).
- Instrument cluster from top yoke ([section 11.1.7](#)).
- Loosen and remove 2 Nos. Hex socket head screws **(M8) (a)** from clamp holding handlebar to top yoke.

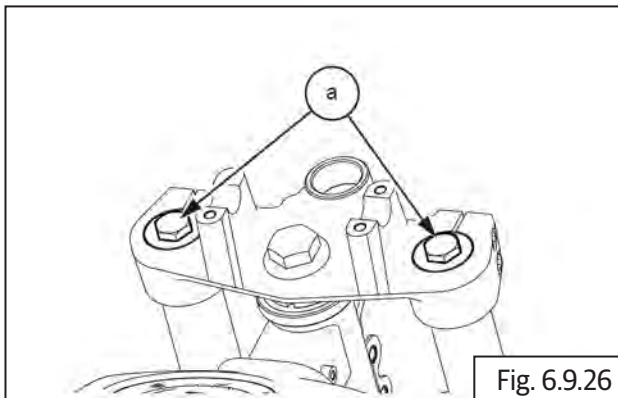

⚠ CAUTION
Support handlebar suitably to prevent damage to master cylinder and controls.

- Loosen and remove top yoke nut **(a)** along with washer.

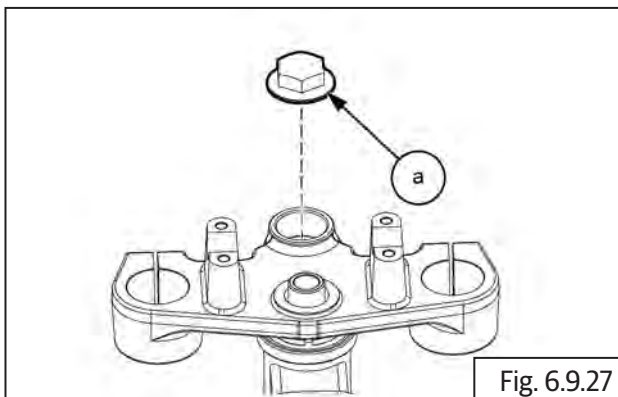

- Ensure free movement of top yoke in steering stem and gently pull out top yoke **(a)** from steering stem.

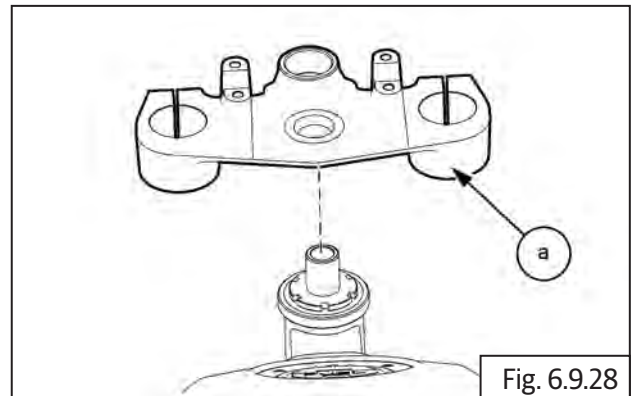

- Turn steering stem to extreme left, loosen and remove stem nut **(a)**.

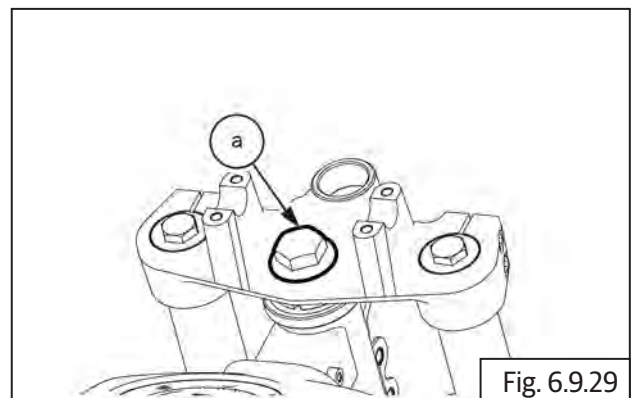

⚠ CAUTION
Support steering stem from bottom. DO NOT allow the steering stem to drop out of frame head tube.

- Hold steering stem from bottom and remove cover head stock **(a)**.

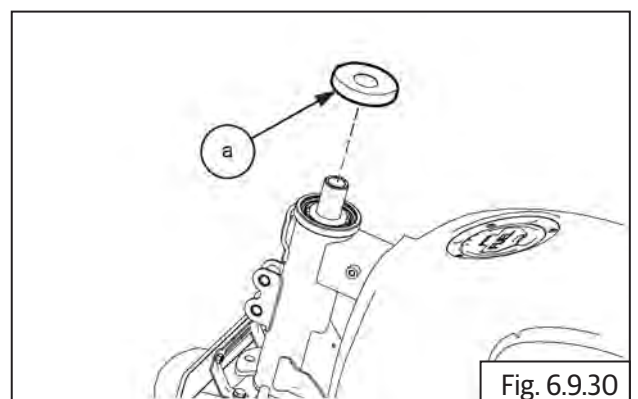

- Hold steering stem from bottom and remove seal head stock **(a)**.

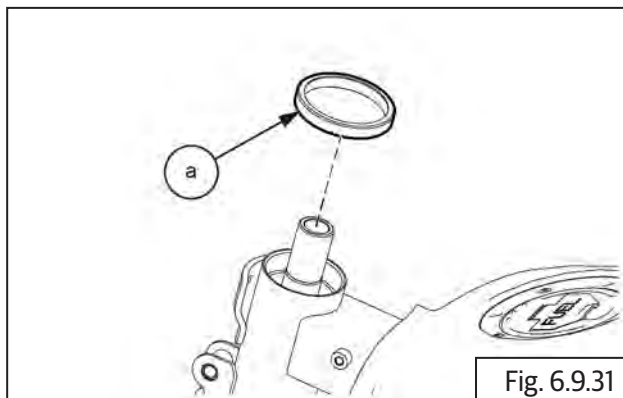

- Gently remove the roller bearing **(a)** from the frame headstock.

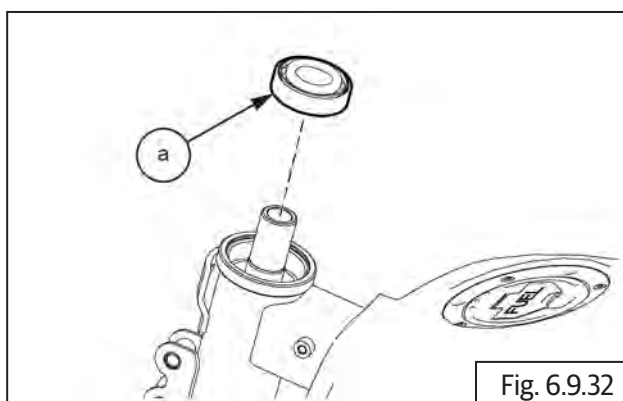

- Gently pull and remove the T Stem **(a)** from the bottom of the frame.

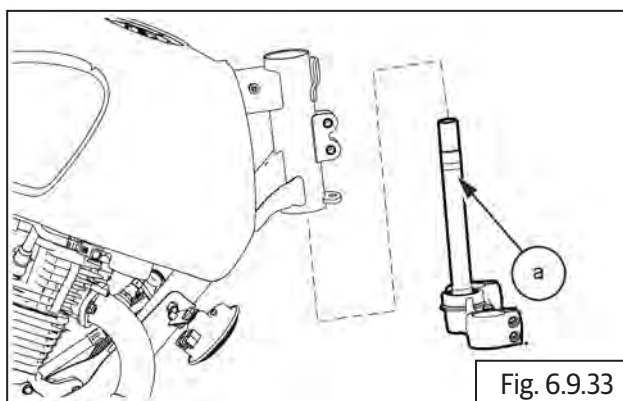

- Remove the stem **(a)** from the bottom yoke.

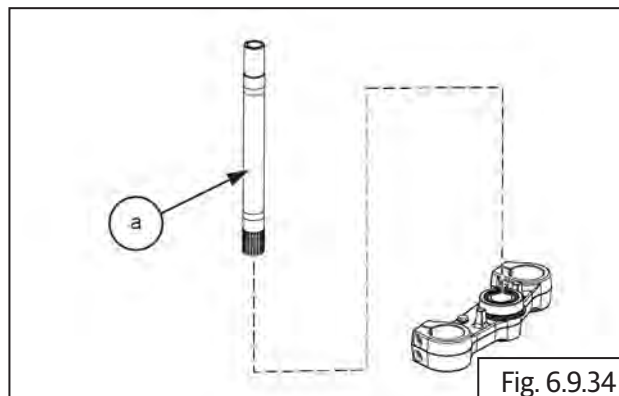

- Remove the bearing **(a)** from bottom of the stem.

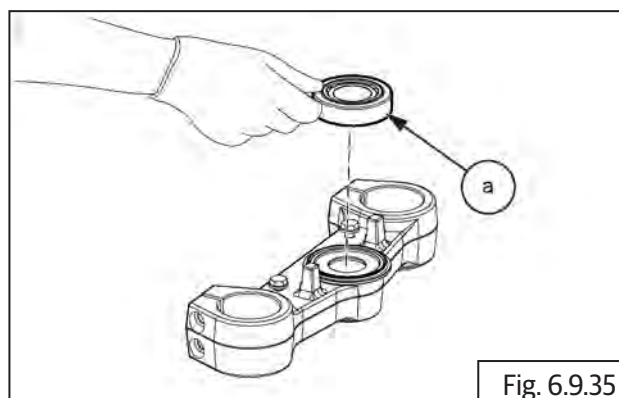

6.9.5. Shock absorber

⚠ CAUTION

Ensure the motorcycle is upright on a firm and flat surface.

- Locate a scissor jack **(a)** under the cradle frame **(b)** and support motorcycle such that the rear wheel is on the ground.

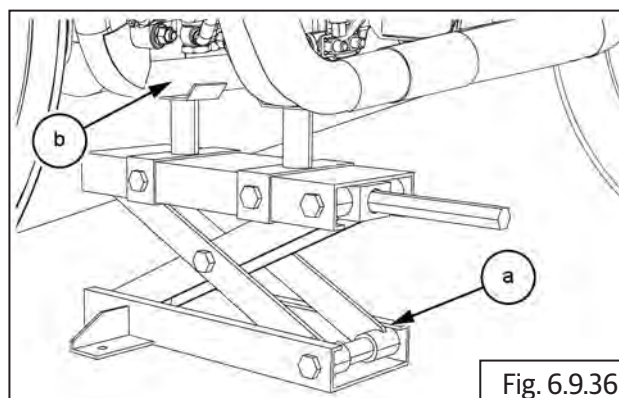

- Ensure ignition and stop switch are in off position.

- Remove the following parts:
 - Pillion and Rider seat:
 - Rear mudguard:
 - Air filter box.
- Remove the bottom bolt **(a)** by holding the nut **(b)**.
- Gently pull and remove the bolt along with the nut.

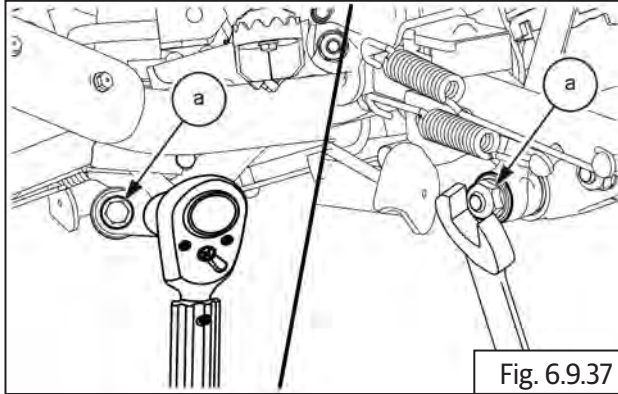

- Remove the top bolt **(a)** by holding the nut **(b)**.
- Gently pull and remove the bolt along with the nut.

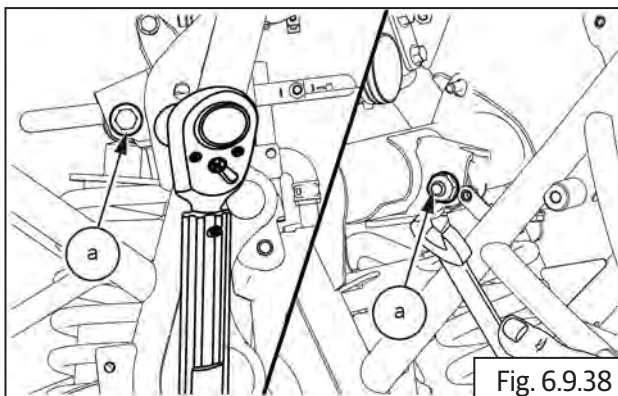

- Gently pull and remove the mono shock absorber **(a)** from the top.

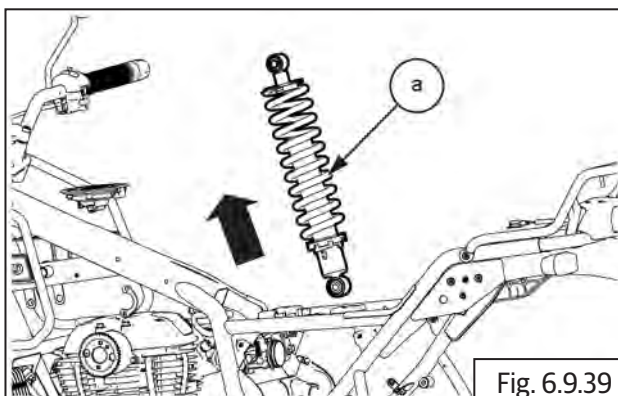

CAUTION

Ensure motorcycle is supported suitably at the rear end after removing both shock absorbers to prevent motorcycle from tipping over and falling down.

6.9.6. Swingarm

- Remove the following parts:
 - Rear wheel ([section 6.8.3](#)).
 - Rear shock absorber ([section 6.9.5](#)).

CAUTION

Ensure the motorcycle is upright on a firm and flat surface. Support the motorcycle firmly while removing the swingarm.

- Remove 1 No **(M6)** bolt to remove the shield covering swing arm spindle from both LH and RH.

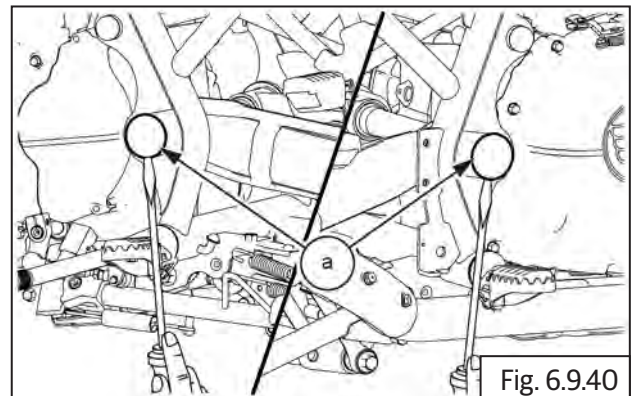

- Hold spindle bolt (**M16**) in frame LH side and loosen and remove hex nut (**M16**) (**a**) with washer (**b**) from RH side.

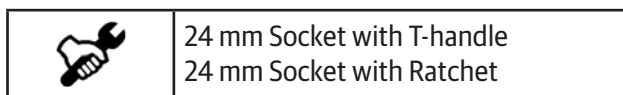
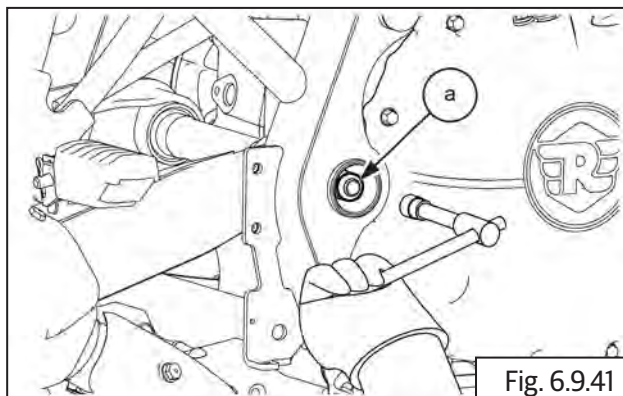

- Provide suitable support below swingarm (**a**) and pull out spindle (**b**) from LH side.

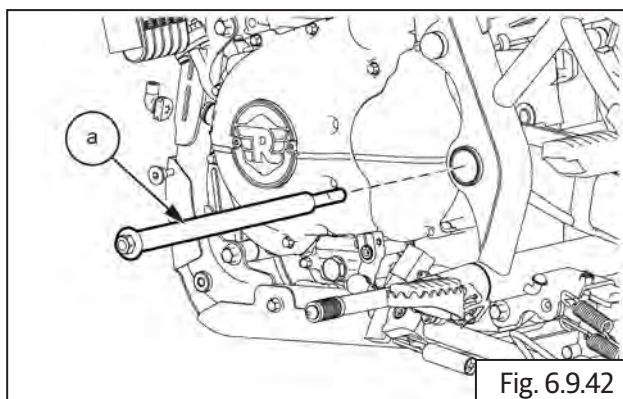

- Loosen and remove 2 Nos. Hex socket button bolts (**M6**) (**a**) to separate chain guard (**b**) from swingarm LH.

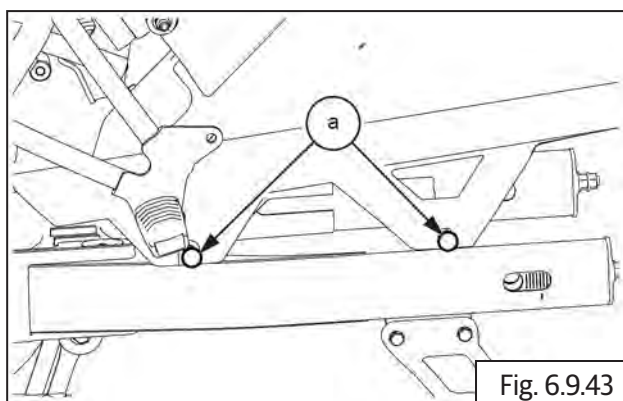

- Rotate swingarm slightly and release drive chain (**a**) from swingarm (**b**).

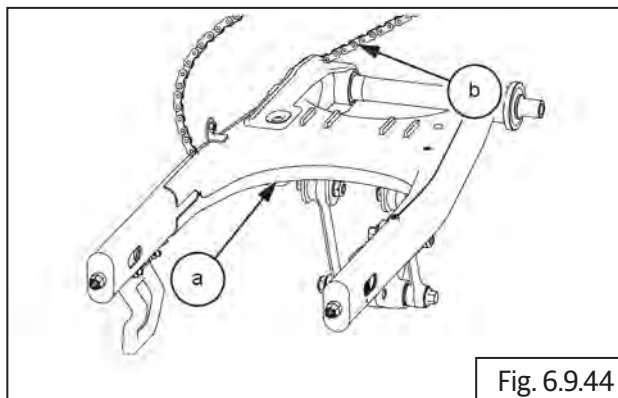

- Remove end cup (**a**) from swingarm LH and RH.

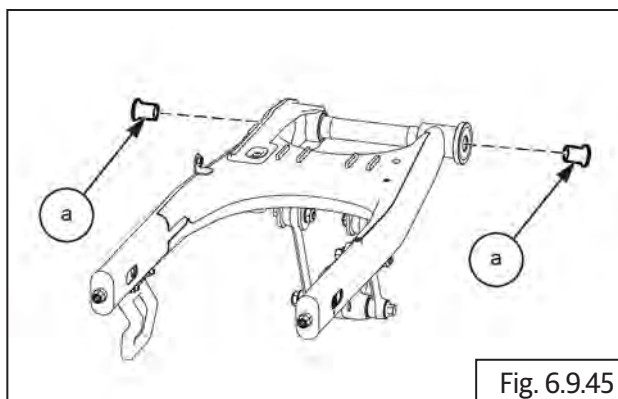

- Remove bush (**a**) from swingarm LH and RH.

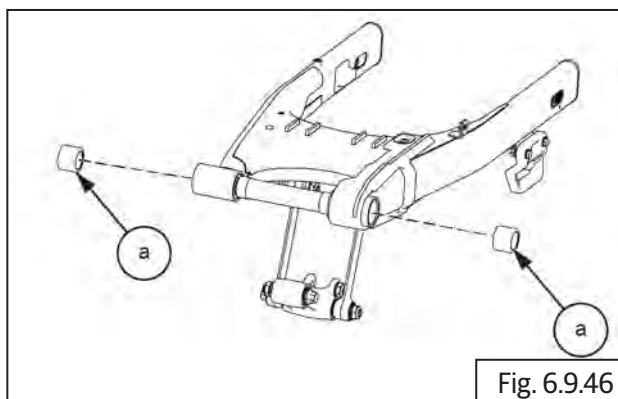

- Remove washer **(a)** from swingarm LH and RH.

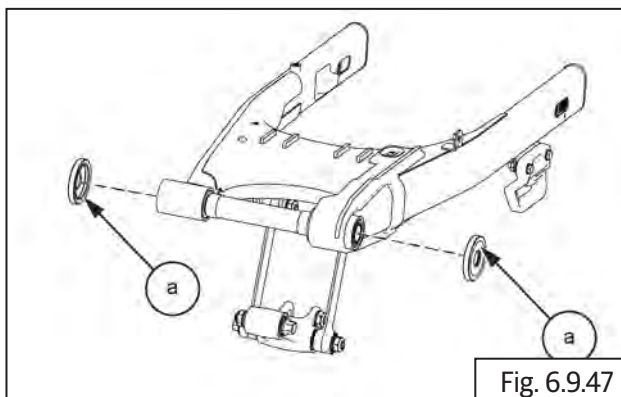

- Remove O-ring (a) from swingarm LH and RH.

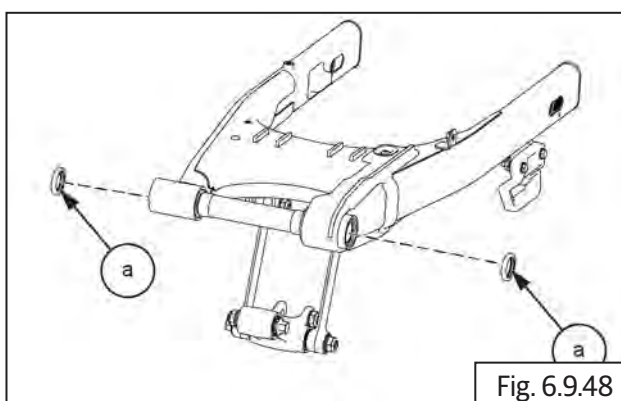

- Remove the 2 Nos. allen bolt **(a)** and remove the supporting plate **(b)**.

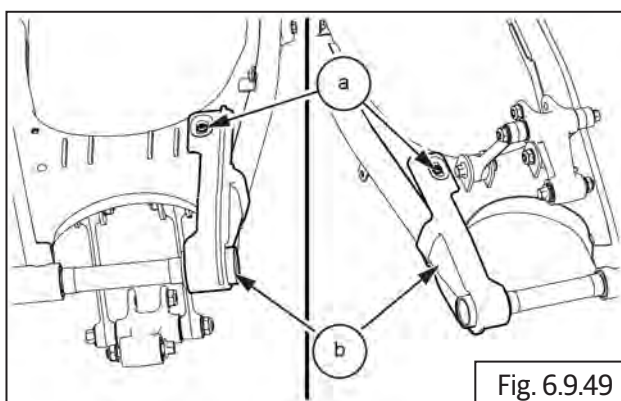

Inspection

6.9.7. Front Fork Leg

- Inspect main tube for any scratches in the working area. Replace if scratched.

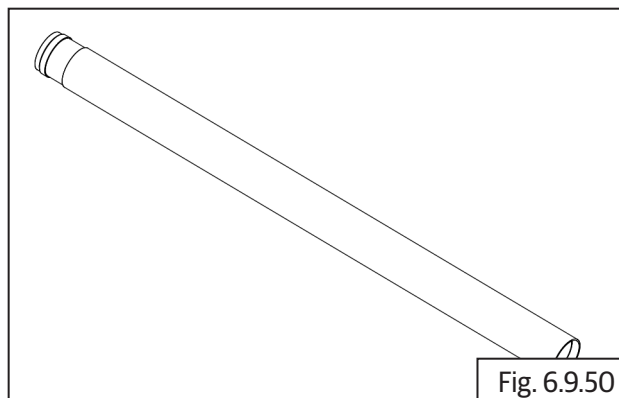

- Fork pipe runout, service limit 0.2 mm.
- Inspect main tubes for any bends using dial gauge.
- Inspect fork ends inner side for any damages and scratches. Replace if found damaged.
- Inspect fork ends for any cracks- especially at oil seated area. Replace if cracked.
- Inspect piston for any damages/scratches. Replace if damaged.
- Inspect main spring for any coil breakage/ reduction in free length and replace. Service limit 303 ± 3.0 mm.
- Inspect damper spring for any coil breakage/ reduction in free length and replace.
- Main spring free length 303 ± 3.0 mm.

6.9.8. Front Fork Air Gap Setting

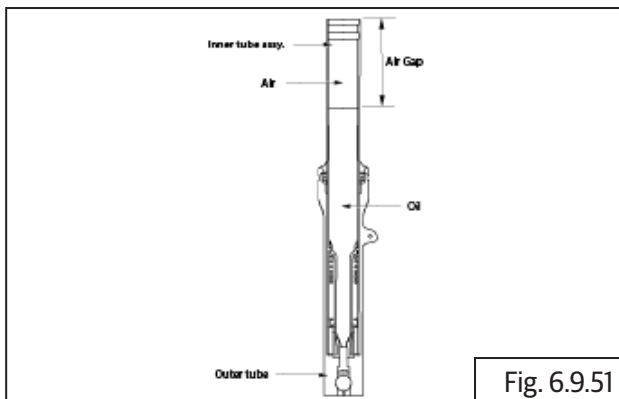

Fig. 6.9.51

- Remove fork leg (LH & RH) assembly from the vehicle.
- Disassemble all parts of the fork external and internal parts with cleaning agent and leave to dry.
- Reassemble fork leg assembly with out main spring, washer spring top, spacer tube, washer-2 and top bolt cap Assy.
- Set the fork leg assembly in a vice or flat surface and ensure it is vertical.
- Fully compress the inner tube assembly in the outer tube until it bottoms out.
- using a cylinder jar measure 453 cc of Gabriel Fork Oil.
- Fill the oil through inner tube top side.
- Hold the outer tube fully extend and fully compress (Stork) the inner tube assy 20-times.
- Fully compress the inner tube assembly and leave for 30- minutes to allow the air to bleed out.

- Measure the height of the oil (Air Gap) using a fork Vernier calliper.

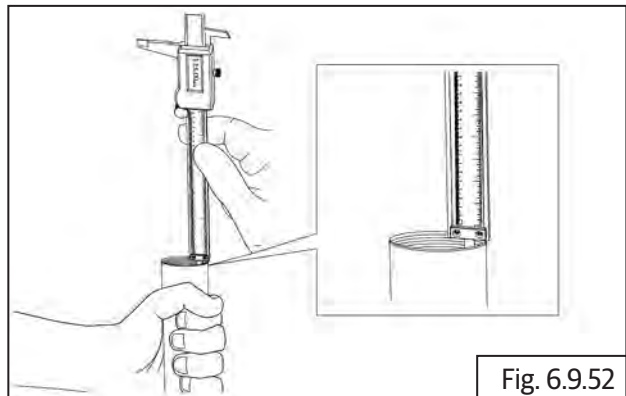

Fig. 6.9.52

- Make vernier "zero", unlock the screw and move the vernier scale towards oil trace side.

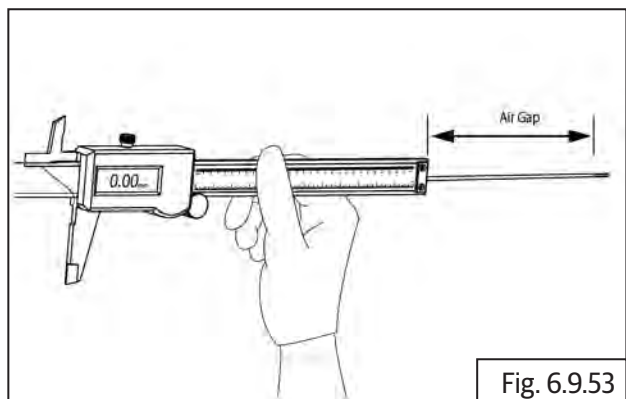

Fig. 6.9.53

- When main scale touch the oil trace, the value is air gap in front fork.

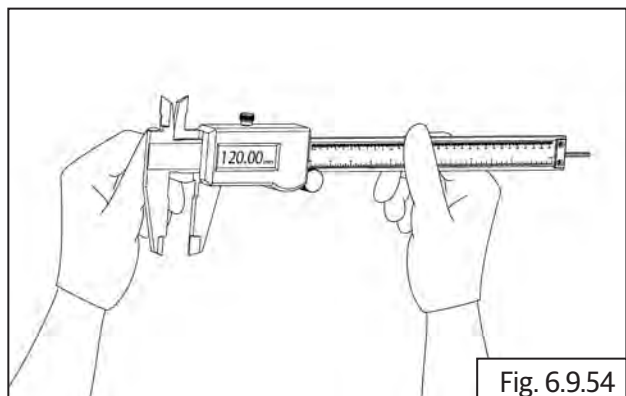
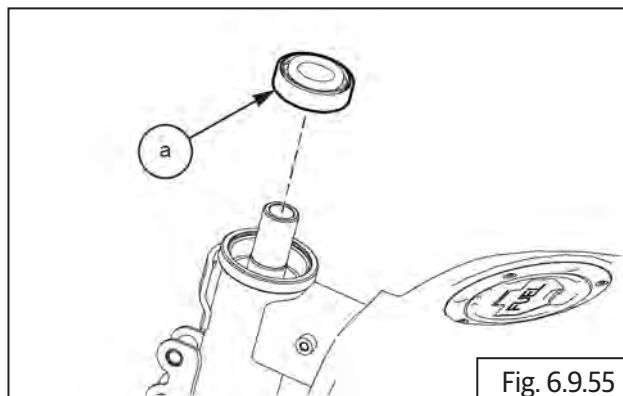

Fig. 6.9.54

6.9.9. Steering Stem

- Inspect and replace roller bearing **(a)** if it has rusting, uneven wear of rollers and/or rollers are falling out of cage.



- Inspect bearing cups for rust, pitting and uneven wear. Replace if damaged.
- Inspect steering stem for any bends or damages. Replace if damaged.

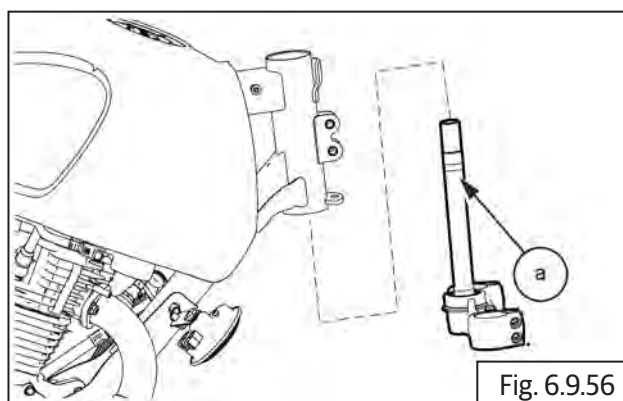

6.9.10. Shock absorber

- Inspect shock absorber for damaged canister, spring coil breakage, oil leaks, weak or hard action of shock absorber. Replace if found.
- Inspect mounting hole rubber inserts for any tear or damage. Replace shock absorber.
- Inspect and replace shock absorber rod if it has any bends, cracks or rusting.

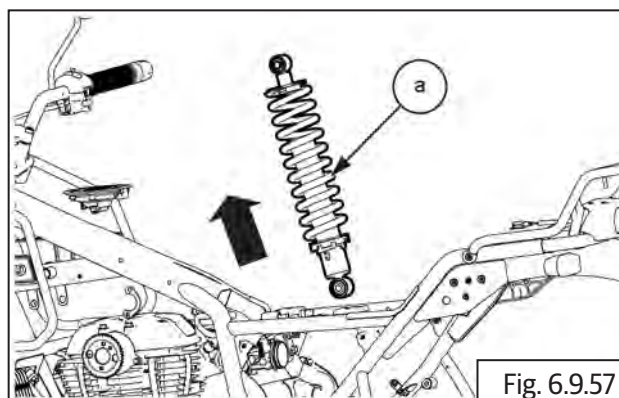

6.9.11. Swingarm

- Inspect LH and RH swingarm for any damages or bends.
- Inspect swingarm in fully assembled condition in motorcycle for side play, sticky movement in working area and replace sleeve if necessary.
- Inspect if swingarm end cup is worn-out or damaged.
- Inspect spindle for any wear-out or bend.

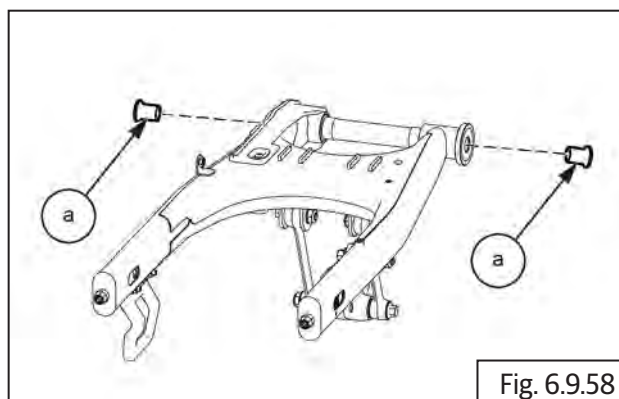

6.9.12. Top Yoke

- Inspect top yoke for any cracks or damages in seating area. Replace if damaged.

Replace

- Replace oil seals, dust seals, washers, chain guides whenever removed from the front fork/swingarm.
- Always fill up front fork with recommended oil from a new container. **DO NOT reuse the oil.**

Assembly

6.9.13. Swingarm

⚠ CAUTION

Ensure the motorcycle is upright on a firm and flat surface.

- Locate rubber chain strap (a) on the LH side, align mounting holes and tighten with 2 Nos. Hex socket button head bolts (M6) (b).

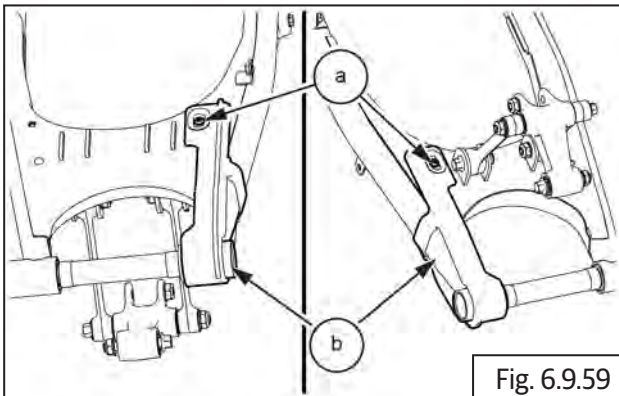

	5 mm Allen key
Torque	4-7 N-m/0.4-0.7 kgf-m

- Locate bush (a) into swingarm LH and RH.

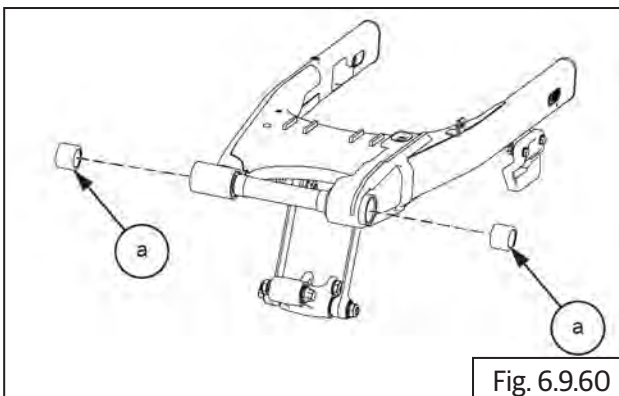

- Assemble end cup (a) into swingarm LH and RH.

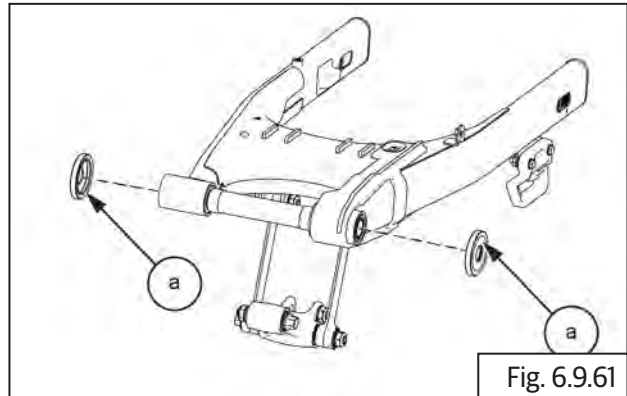

- Insert drive chain (a) into swingarm (b) LH.

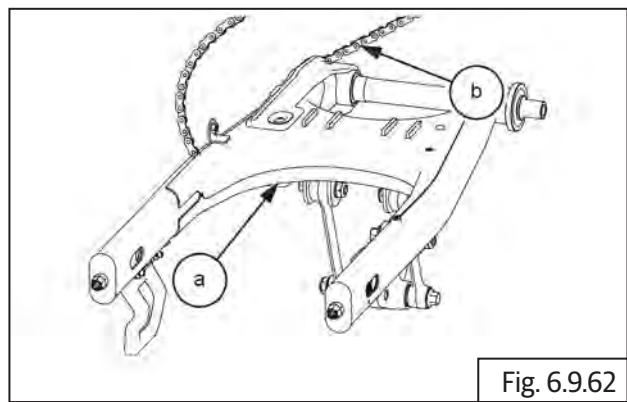

- Locate and align chain guard front mounting hole on swingarm RH (b) and tighten with Hex socket button head bolt (M6) (a).

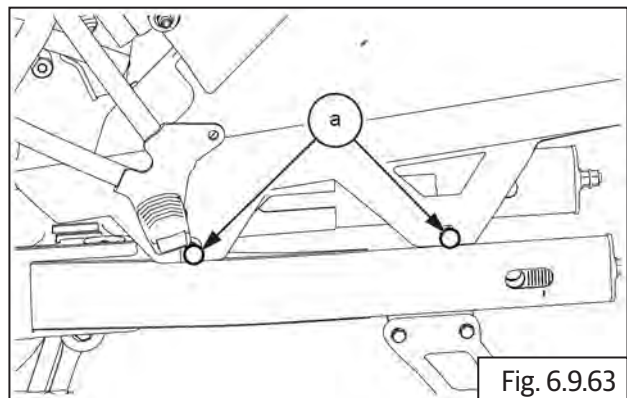

	5 mm Allen key
Torque	4-7 N-m/0.4-0.7 kgf-m

- Position swingarm assembly **(a)** into frame and ensure mounting holes are aligned properly.

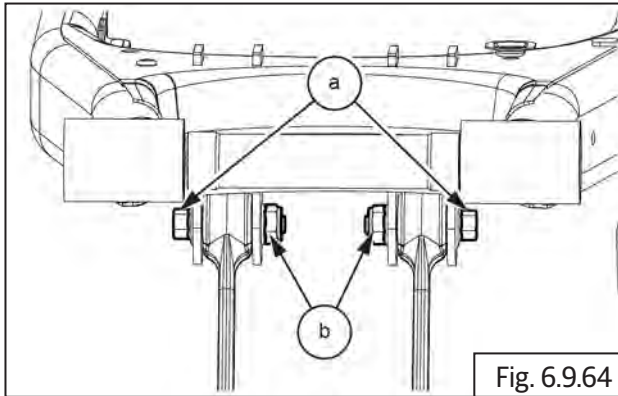

- Insert spindle **(a)** from LH till it is located on the end cap with slots.

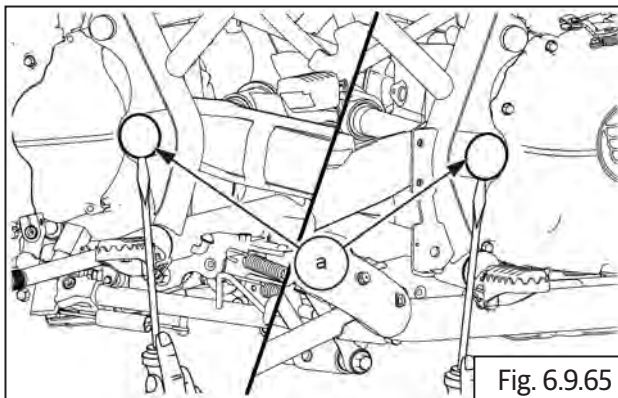

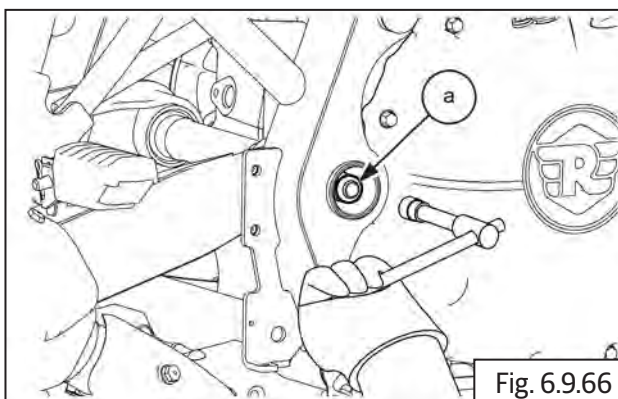

- Locate Hex nut **(M16) (a)** along with washer **(b)** on spindle.
- Hold spindle from LH side suitably and tighten nut.

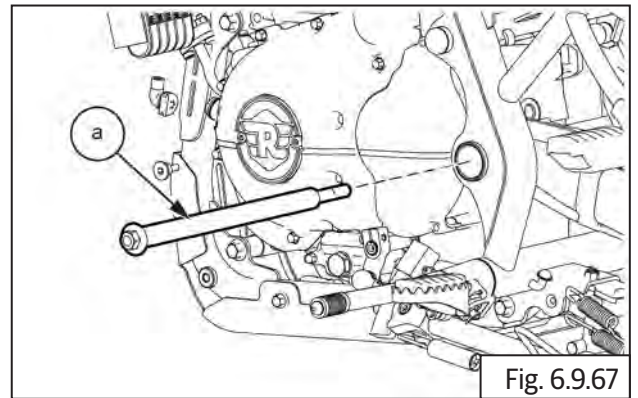

	24 mm Socket with Ratchet
Torque	66-74 N·m/6.6-7.4 kgf·m

- Insert mounting bolt (a) (M6) and tighten.



	10 mm Socket with Ratchet
Torque	10-12 N·m/1.01-2 kgf·m

6.9.14. Shock Absorber

⚠ CAUTION

Ensure the motorcycle is upright on a firm and flat surface.

- Locate and align the shock absorber top **(a)** to mounting hole on frame **(b)** and tighten with button head bolt **(M8) (c)**.

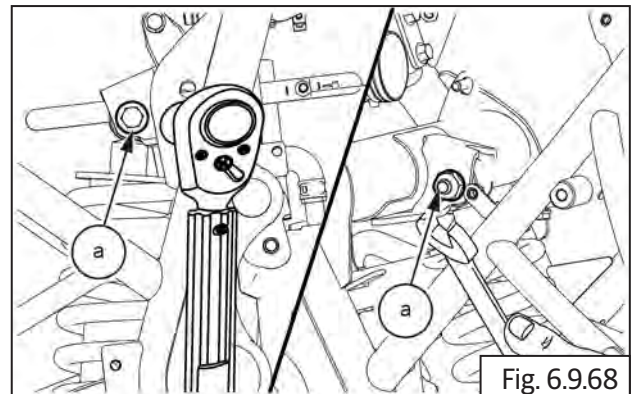

	6 mm Allen socket and Ratchet
Torque	25-35 N·m/2.5-3.5 kgf·m

- Align bottom mounting hole of shock absorber (a) to swingarm bracket LH (b) and tighten with button head bolt (M8) (c).

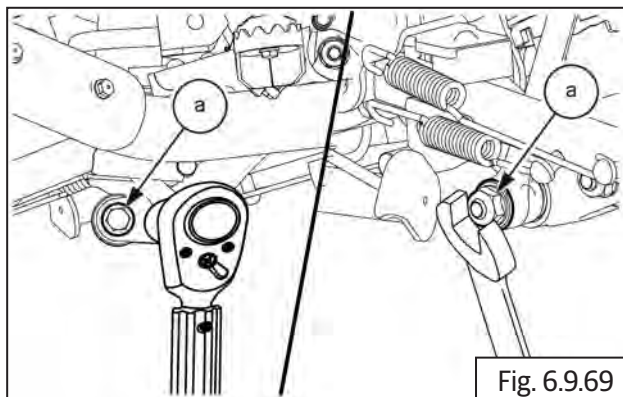



Fig. 6.9.69

	6 mm Allen socket and Ratchet
Torque	25-35 N·m/2.5-3.5 kgf-m

- Tighten both mounting bolts evenly to torque.

6.9.15. Steering Stem Assembly into Frame Head Tube

- Insert the dust seal (a) and roller bearing (b).

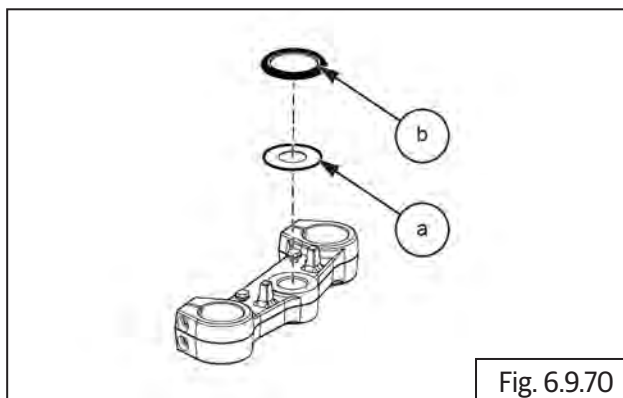

Fig. 6.9.70

6.9.17. Steering Stem on Frame Head Tube

- Apply Royal Enfield recommended grease on the bearing cups inner surface.
- Insert steering stem (a) into frame head tube from the bottom.

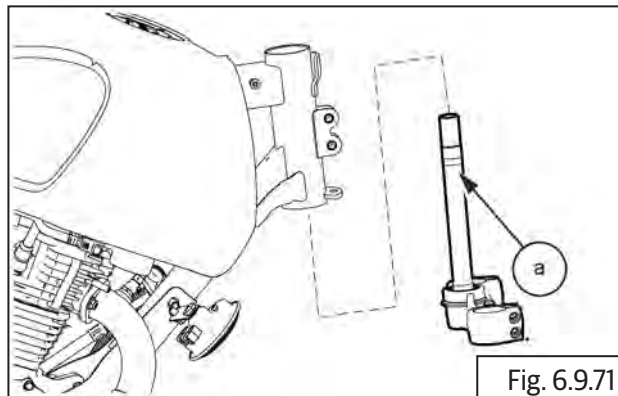

Fig. 6.9.71

⚠ CAUTION

Support steering stem from bottom. DO NOT allow the steering stem to drop out of frame head tube.

- Assemble headstock bearing with the taper facing upwards (a).

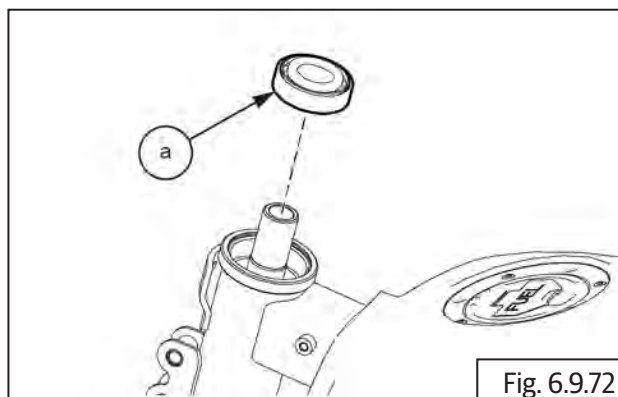

Fig. 6.9.72

- Assemble bearing guide (a) with the cup facing downwards.

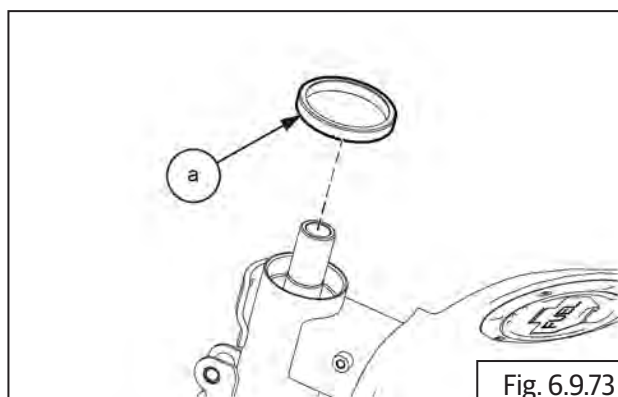

Fig. 6.9.73

- Assemble headstock seal **(a)** with the cup facing downwards.

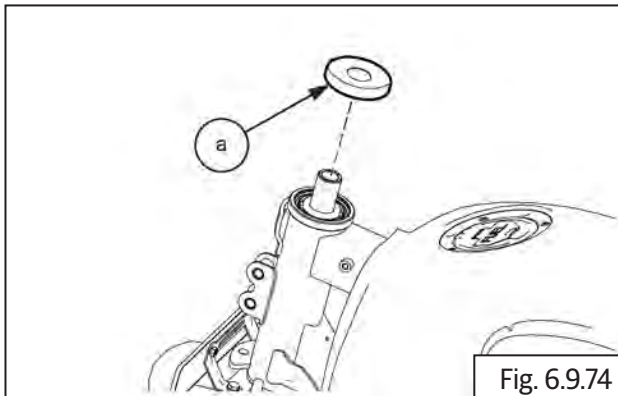

Fig. 6.9.74

- Install the top youck **(a)**.

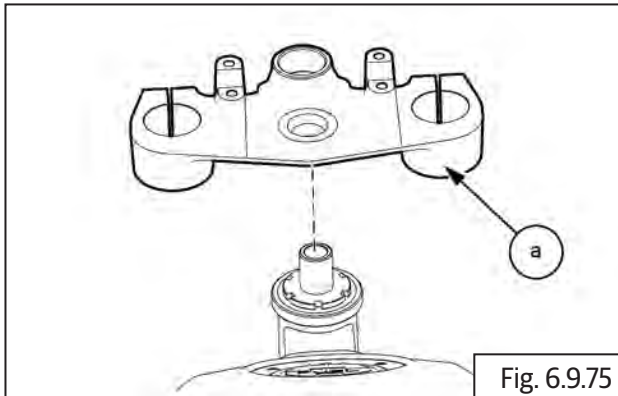

Fig. 6.9.75

- Assemble stem nut **(a)** on steering stem and tighten.

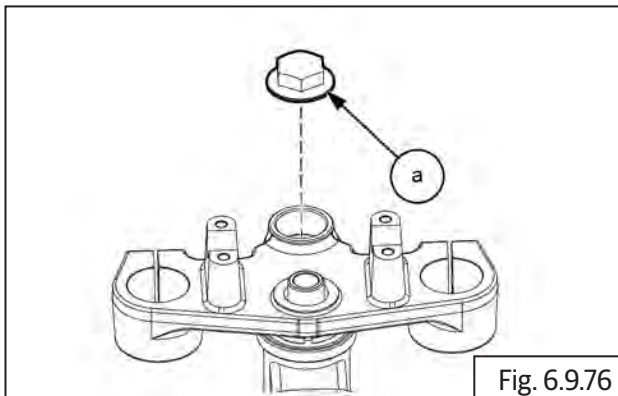

Fig. 6.9.76

Check the following

- Check the free movement of steering stem from left to right.
- Check axial play of steering stem at center, extreme left and right positions.
- Check lateral play of steering stem at center, extreme left and right positions.

- Tighten or loosen stem nut to ensure no axial or lateral movement is present and the steering movement is smooth.

⚠ CAUTION

DO NOT over tighten the nut. Over/under torquing will lead to improper adjustment of steering stem.

Check for smooth turning in left and right directions and tighten just sufficiently.



8 mm Allen socket with Ratchet

Torque

8 N·m/0.8 kgf·m

6.9.19. Front Fork Sub Assembly LH and RH

- Assemble spring **(a)** into piston from the bottom end **(b)**.

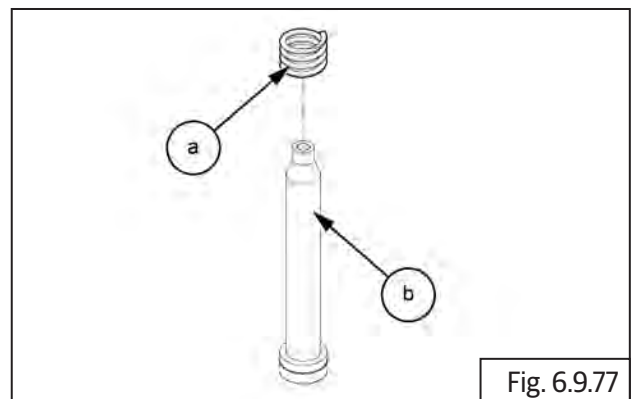

Fig. 6.9.77

- Locate special tool **(a)** on piston **(b)** with the piston facing upwards.

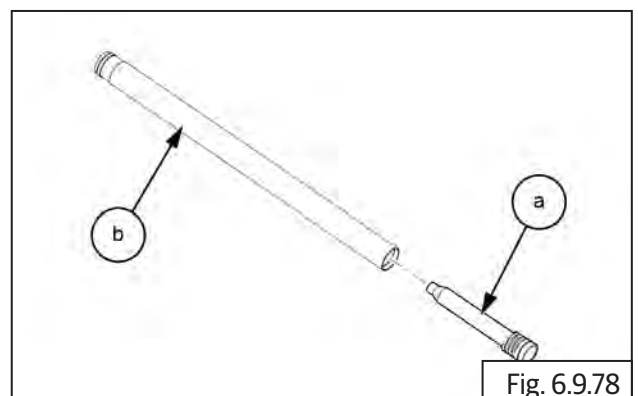
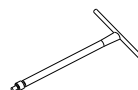

Fig. 6.9.78

SPL



Part No: ST26461-2

Part Name: Fork damper tube holder

- Assemble slide bush (a) into main tube (b) from fork top.

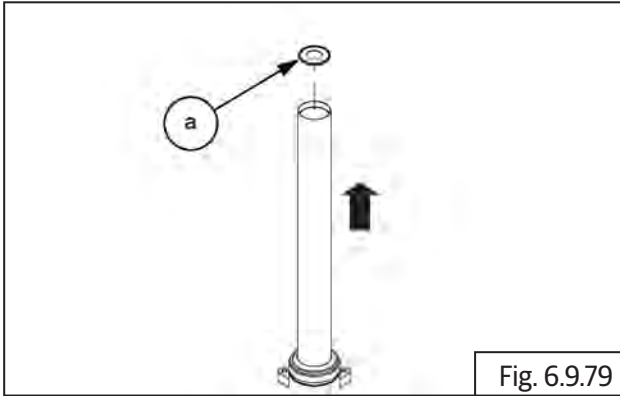

- Assemble fork main tube (a) on piston (b) with the threads on the main tube inner facing downwards. Ensure the piston is guided out of the main tube.

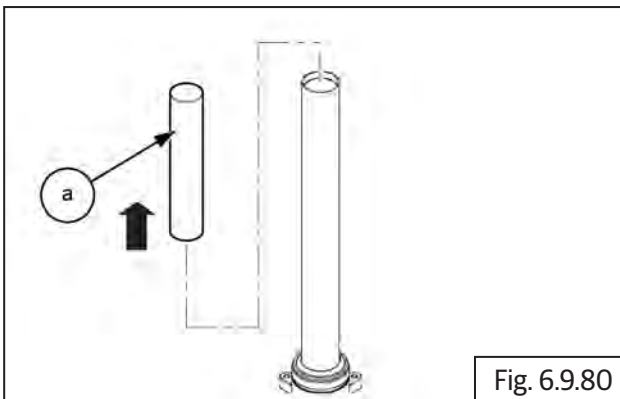

	Part No: ST26461-2
	Part Name: Fork damper tube holder

- Assemble taper oil lock (a) on piston (b). Apply little grease to lock on its place.

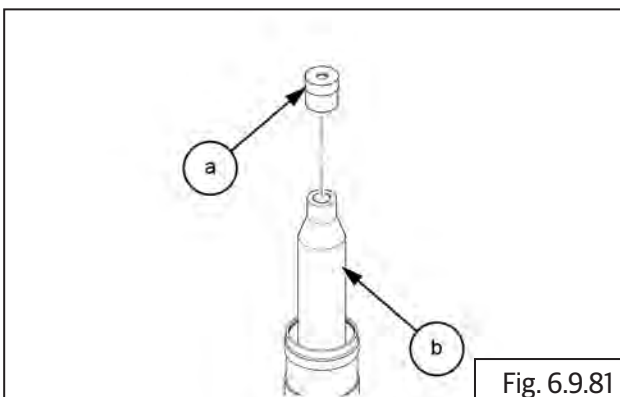

- Assemble bottom tube top (a) over main tube (b). Ensure it is seated on taper oil lock.

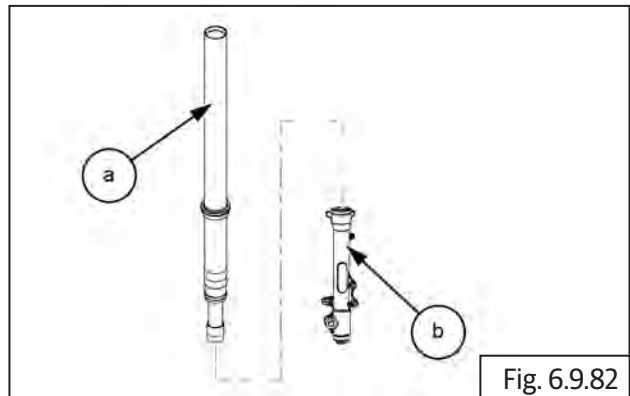

- Locate hex socket head screw (M6) (a) along with washer (b) into mounting hole in bottom tube and tighten to torque.

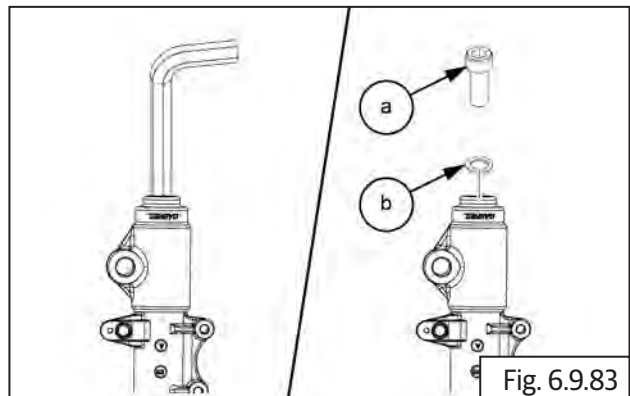

	5 mm Allen socket with Ratchet
Torque	10 N·m/2.0 kgf·m

- Remove the special tool.
- Insert washer (a) on the main tube and ensure proper seating into the bottom tube.

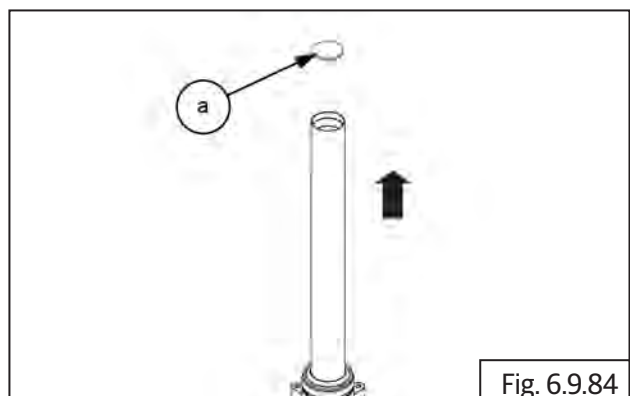

- Assemble oil seal **(a)** on main tube **(b)** with the lip facing upwards.

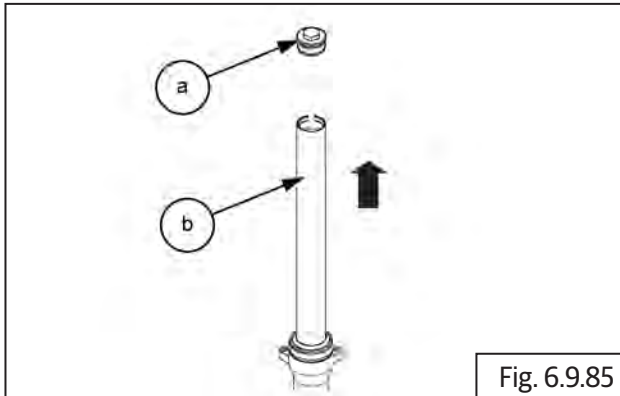

Fig. 6.9.85

- Locate special tool **(a)** on main tube and drive oil seal into bottom tube till it is seated fully and the seal clip groove in bottom tube is visible.

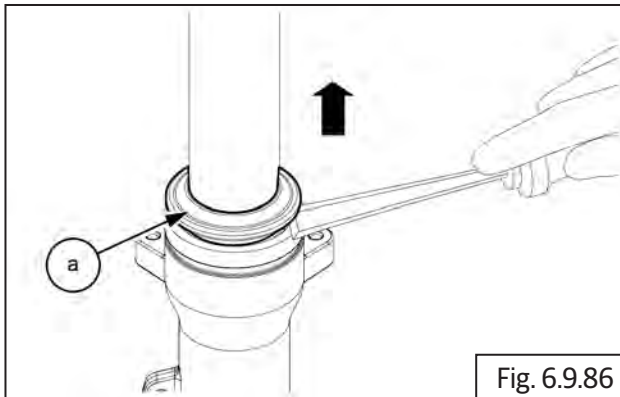

Fig. 6.9.86

	Part No: ST26485-3
	Part Name: Fork oil seal installer

- Remove special tool from fork inner tube.
- Assemble seal clip **(a)** over oil seal and ensure it is seated properly on the groove in bottom tube.

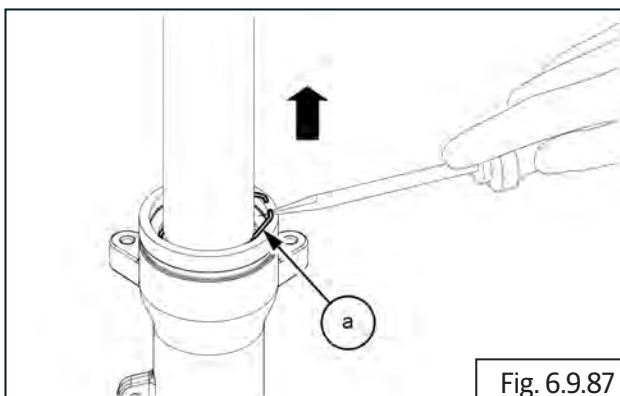

Fig. 6.9.87

- Assemble dust seal **(a)** from main tube top **(b)** with closed ends upwards. Using special tool **(c)**, drive dust seal into bottom tube till it is flush with top surface of bottom tube.
- Ensure free up and down movement of the main tube into bottom tube.
- Holding bottom tube, gently pull out main tube to its maximum stop ends position.
- Insert spring **(a)** into main tube with its closed coils facing downwards.

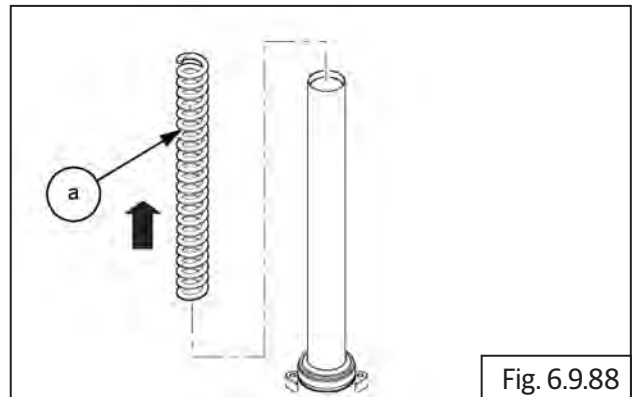

Fig. 6.9.88

- Fill recommended fork oil into main tube.

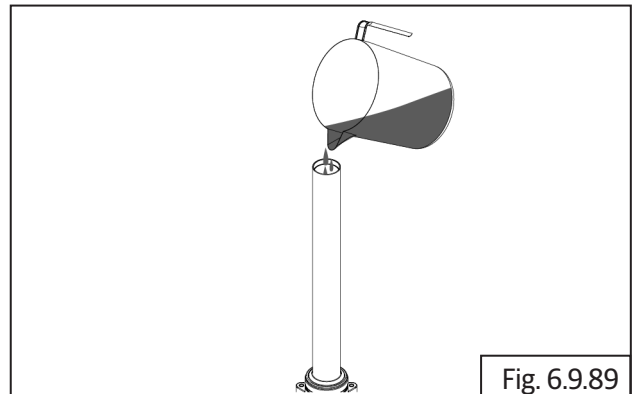
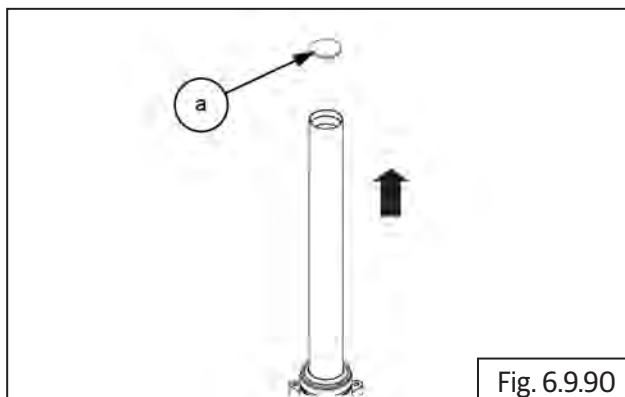

Fig. 6.9.89

Quantity:	453 ml/fork
Oil grade:	2w25

- Replace with new oil whenever the oil drained from fork.
- Check oil quantity and fill with recommended fork oil with specified grade. Specified oil grade: 10Wt (Fork Oil Quantity = 453 ml per fork).
- Insert steel plate **(a)** into main tube over spring top.



- Assemble spacer tube **(a)** into main tube.

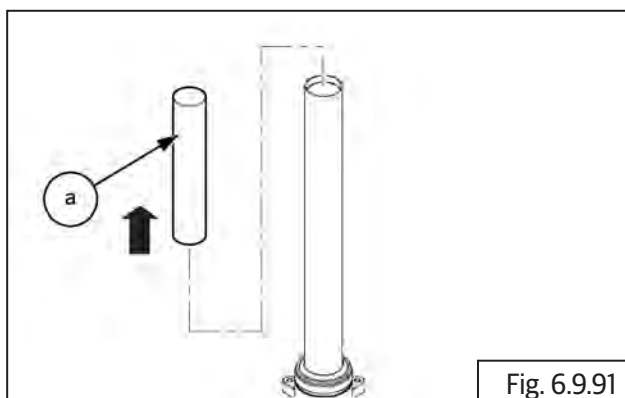

- Assemble plain washer **(a)** over spacer tube.

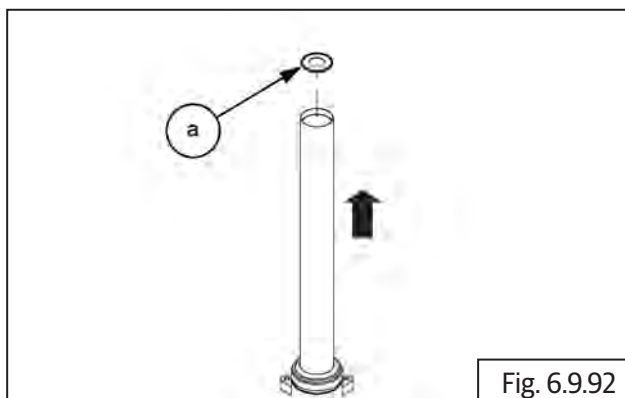

- Locate O-ring **(a)** on cap nut **(b)**, position it over washer correctly, gently push down cap nut till threads engage in main tube **(c)** and tighten fully.

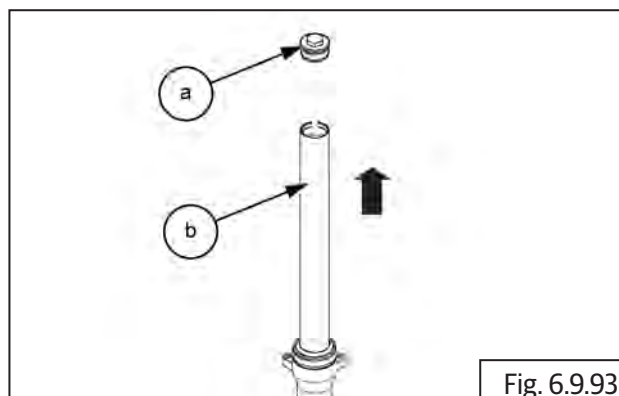

	22 mm Ring spanner
Torque	20 N-m/2.0 kgf-m

⚠ CAUTION

Ensure thread are engaged correctly to prevent damage to cap nut/main tube threads

6.9.20. Front Fork LH and RH Assembly on Motorcycle

- Ensure pinch bolts on LH and RH sides of the steering stem and top yoke are sufficiently loose.
- Ensure the steering stem and top yoke fork mounting holes are aligned.
- Position headlamp holder RH between steering stem and top yoke.
- Insert fork assembly RH **(a)** into steering stem **(b)**, headlamp holder, handlebar clip on and top yoke.

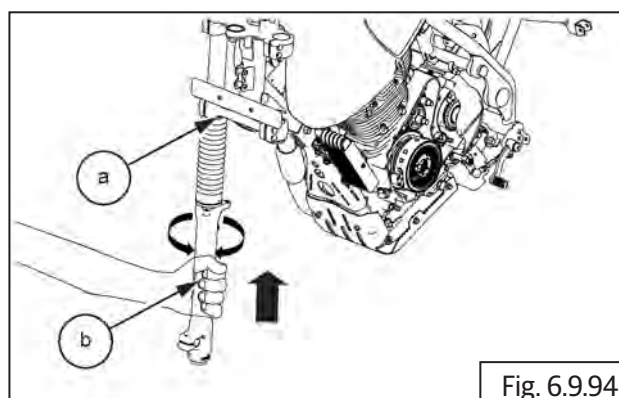

- Gently tighten the top pinch bolt in steering stem RH to prevent fork from dropping down.
- Repeat above process to assemble fork assembly LH.
- Ensure fork assembly RH and LH top is **10 mm** above and hex cap nut is above the top yoke.

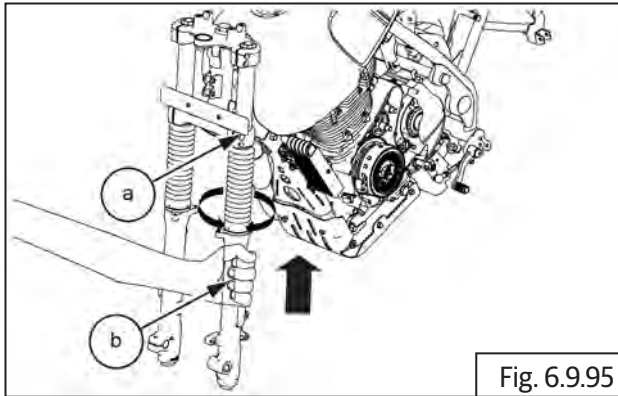

- Tighten 4 Nos. Hex socket head bolts (**M8**) (a) each on the steering stem and top yoke LH and RH sides.

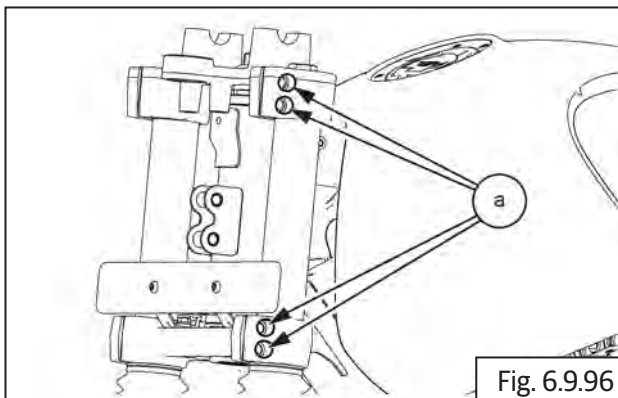

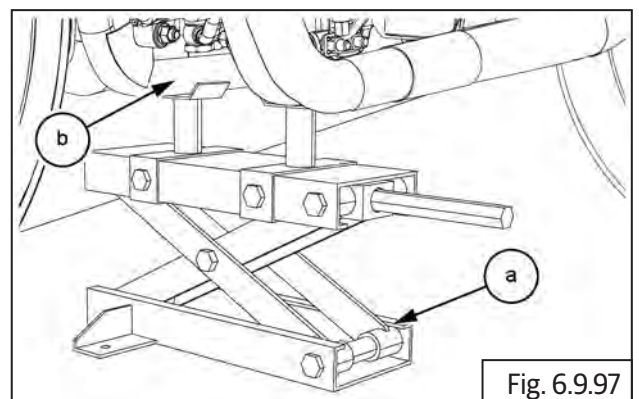

	6 mm Allen socket with Ratchet
Torque	21-29N-m/2.1-2.9 kgf-m

- Reassemble the following parts:
 - Assemble Ignition switch and connect wiring connector ([section 11.12.2](#)).
 - Instrument cluster and connect wiring connector ([section 11.12.5](#)).
 - Trafficators LH and RH and connect wiring coupler ([section 11.9.1](#)).
 - Headlamp assembly ([section 11.12.1](#)).
 - Headlamp housing between headlamp holder LH and RH ([section 11.12.4](#)).
 - Front number plate - India ([section 6.6.16](#)).
 - Front mudguard ([section 6.6.15](#)).
 - Wheel caliper on fork end LH ([section 9.2.8](#)).
 - ABS wheel speed sensor on fork end LH ([section 9.3.9](#)).
- Position brake hose and ABS wheel speed sensor in the clamps on the LH side.
- Locate wheel speed sensor on RH side of the wheel hub, position front wheel between fork ends, ensure speed sensor is correctly positioned against fork end RH. Insert front wheel axle into fork end and tighten to torque ([section 6.8.13](#)).
- Support motorcycle underneath cradle frame such that front wheel is off the ground by minimum 6 inches/15 cm.

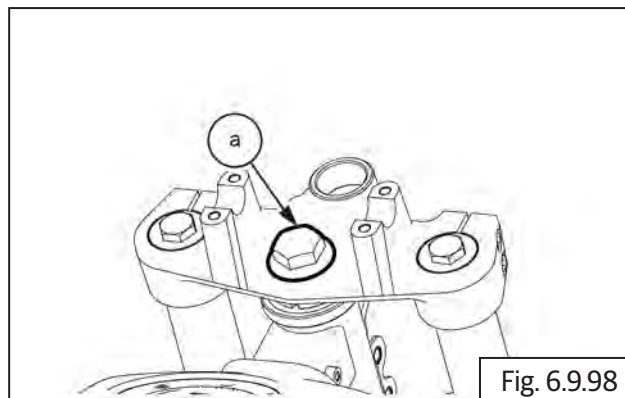

- Turn handlebar to extreme left and right position and check for free and smooth rotation.
- Hold the front wheel straight ahead, check for any play.
- Gently push front wheel upwards and release, check for any play.
- Tighten top nut **(a)** on top yoke to torque.



	27 mm Hex socket with Ratchet
Torque	32-38 N-m/3.2-3.8 kgf-m

6.9.21. Steering Stem Play Adjustment

- Ensure the motorcycle is on a firm and flat surface.
- Ensure front wheel is off the ground. Turn handlebar to extreme LH and RH side to check for free movement. Hold handlebar in straight position and gently lock the motorcycle keeping a finger underneath top yoke to check for any axial or lateral movement.
- If movement is found adjust as follows:
- Loosen top nut **(a)** on top yoke.

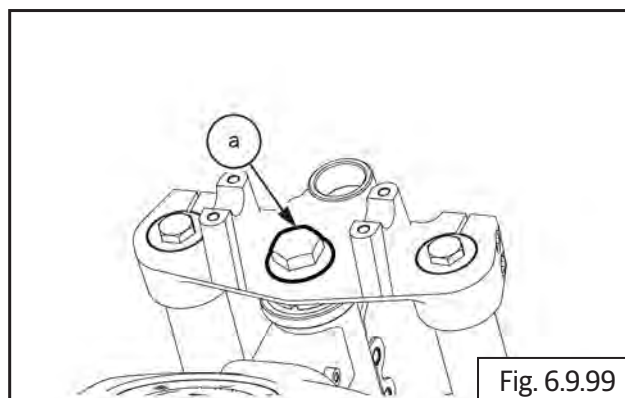

	27 mm Allen socket with Ratchet
---	---------------------------------

- Loosen 4 Nos. Pinch bolts **(M6) (a)** on top yoke LH and RH side (fork main tube area).

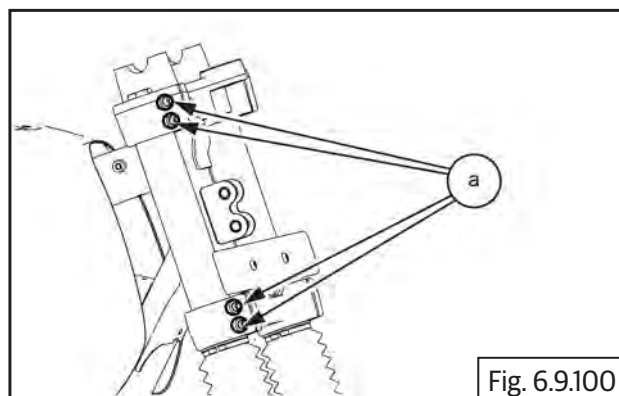

	6 mm Allen socket with Ratchet
---	--------------------------------

- Locate stem nut **(a)** and tighten gently.

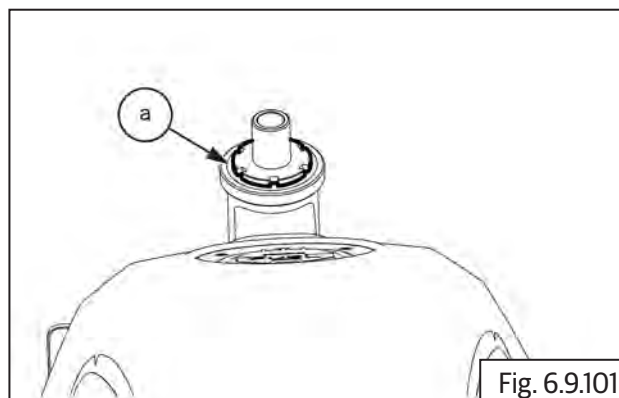

NOTE
• After a set torque of 8 N-m do not steer the motorcycle.

- Check for free rotation and no axial or lateral movements.
- Tighten pinch bolt on top yoke and stem nut.
- Tighten 4 Nos. pinch bolts to specified torque 20 N-m/2.0 kgf-m.

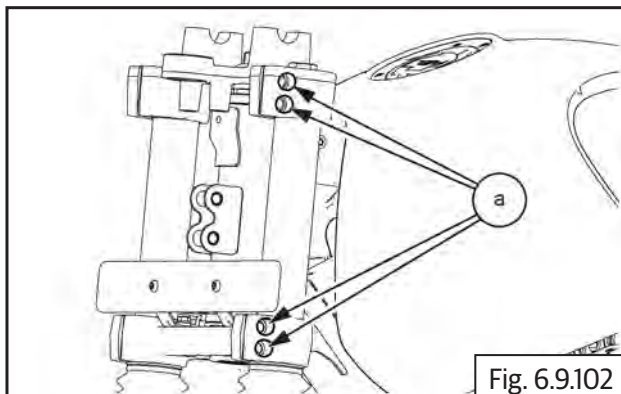

Fig. 6.9.102

	6 mm Allen socket with Ratchet
---	--------------------------------

- Tighten top nut (**a**) on top yoke.

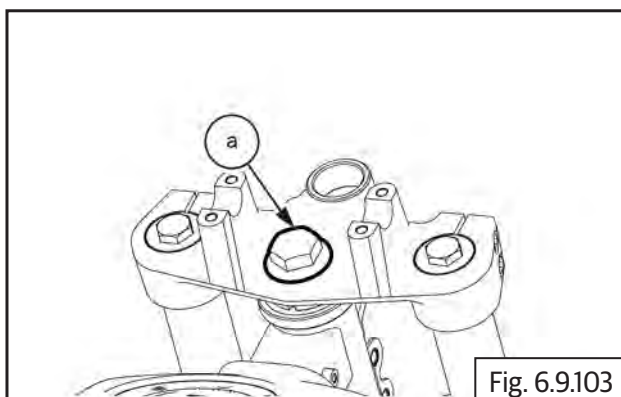



Fig. 6.9.103

	27 mm Allen socket with Ratchet
Torque	32-38 N-m/3.2-3.8 kgf-m

Troubleshooting

Symptom	Possible Cause	Diagnosis	How to Fix	Recommended Specification
1. Front Fork/Steering Stem Related				
Oil leak from fork assembly LH/RH	Excessive oil is filled.	Excessive oil is filled in fork legs.	Dismantle fork legs, drain oil and fill correct recommended oil quantity.	Royal Enfield front fork oil 2W 25. Quantity 453 ml/ fork.
	Oil leaks from top cap nut.	Cap nuts are loose/sealing washer is damaged.	Tighten Cap nuts/replace sealing washer.	
	Oil leaks between main tube and guide tube is faulty.	Oil seals are worn-out or not seated evenly/loose in guide tubes.	Dismantle fork legs and replace oil seals.	
	Oil leaks from guide tube bottom.	Oil leaks from Hex socket bolt at the bottom of guide tube.	Dismantle fork legs and replace sealing washer bottom and reassemble.	
Hitting noise from front fork/s	Oil quantity is less in one/both fork legs.	Oil quantity mismatched between LH and RH fork assemblies.	Dismantle fork legs, drain oil and fill with correct recommended quantity.	Royal Enfield front fork oil 2W 25. Quantity 453 ml/ fork.
	Fork main springs have become soft/ coils are broken/ length is reduced.	Fork main springs have lost tension/Overall length of the main springs is reduced/coils are broken.	Dismantle fork legs and replace fork main springs.	Main spring length: 303 ± 3.0mm.
	Rebound spring has become soft/broken/ length is reduced.	Rebound springs have lost tension/overall length is reduced/coils are broken.	Dismantle fork legs and replace rebound springs.	
	Taper oil lock is not seated properly/is loose on piston tube.	Taper oil lock is seated unevenly/loose in piston tube/hex socket bolt at fork end bottom is loose.	Dismantle fork leg assemblies, check for uneven seating/loose fittings and replace taper oil lock/fork piston assembly.	
Fork action is soft	Oil quantity is less in one/both fork legs.	Oil quantity mismatched between LH and RH fork assemblies.	Dismantle fork legs, drain out oil and fill with correct recommended quantity.	Royal Enfield front fork oil 2W 25. Quantity 453 ml/ fork.
	Fork main springs are soft/coils are broken/ length is reduced.	Fork main springs have lost tension/overall length of main springs is reduced/coils are broken.	Dismantle fork legs and replace fork main springs.	Main spring length: 303 ± 3.0mm.

Symptom	Possible Cause	Diagnosis	How to Fix	Recommended Specification
Fork action is hard	Excessive oil is filled in fork assembly LH/ RH.	Excessive oil is filled in the fork legs.	Dismantle fork legs, drain oil and fill with correct recommended quantity.	Royal Enfield front fork oil 2W 25. Quantity 453 ml/ fork.
	Fork main tube movement in fork ends is sticky.	Fork main tube is bent.	Dismantle fork legs, check main tube for straightness and replace main tubes.	
		Fork end tubes are damaged.	Dismantle fork legs, check fork ends inside for excessive wear-out.	
Riding is unstable	Tyre seating on rims is improper.	Tyre bead is uneven at the rim surface.	Remove tyre and reassemble correctly.	
	Wheel rims are out of trueness.	Wheel rims are bent/have excessive run-out.	Remove tyre and true the wheel rim correctly.	
	Wheel rims have a crack/heavy damage.	Wheel rims have been cracked/damaged due to impact.	Replace with Royal Enfield genuine wheel rims.	
	Wheels have excessive axial/side play.	Wheel bearings are worn-out	Remove bearing and replace	
	Hubs front/rear are cracked/damaged	Wheel hubs are damaged due to impact.	Replace with Royal Enfield genuine hubs.	
	Oil quantity is mismatching in LH and RH fork legs.	Oil quantity mismatched between LH and RH fork assemblies.	Dismantle fork legs, drain oil and fill with correct recommended quantity.	Royal Enfield front fork oil 2W 25. Quantity 453 ml/ fork.
	Fork main springs have become soft/ coils are broken/ length is reduced.	Fork main springs have lost tension/Overall length of the main springs is reduced/coils are broken.	Dismantle fork legs and replace fork main springs.	Main spring length: 303 ± 3.0mm.
	Fork main tube movement in fork end is sticky.	Fork main tube is bent.	Dismantle fork legs, check main tube for straightness and replace main tubes.	
		Fork end tubes are damaged.	Dismantle fork legs, check fork ends inside for excessive wear-out and replace.	
	Steering stem movement is not smooth.	Control cables/wiring harness is not routed properly.	Route the control cables/ wiring harness correctly and strap to frame.	
		Steering stem nut is excessively tightened.	Adjust the steering stem nut correctly.	
		Steering stem bearings rollers have sticky movement/is rusted/bearing is damaged/uneven seating.	Dismantle steering stem and replace bearings.	
	Steering stem is bent.	Steering stem is bent.	Replace steering stem.	

Symptom	Possible Cause	Diagnosis	How to Fix	Recommended Specification
Vehicle is pulling to one side	Tyre pressures are less/more than recommended.	Front and rear tyre pressures are under/over inflated.	Ensure correct tyre pressures.	Solo: Front tyre: 32 psi/2.2 kg/cm ² . Rear tyre: 36 psi/2.53 kg/cm ² . With Pillion: Front tyre: 32 psi/2.2 kg/cm ² . Rear Tyre: 39 psi/2.74 kg/cm ² .
	Wheels alignment is not proper.	Front and rear wheels are not aligned.	Align front and rear wheels correctly.	
	Oil quantity is mismatching in LH and RH fork legs.	Oil quantity is mismatched between LH and RH fork assemblies.	Dismantle fork legs, drain out the oil and fill with correct recommended quantity.	Royal Enfield front fork oil 2W 25. Quantity 453 ml/ fork.
	Fork main springs have become soft/ coils are broken/ length is reduced.	Fork main springs have lost tension/Overall length of the main springs is reduced/coils are broken.	Dismantle fork legs and replace fork main springs.	Main spring length: 303 ± 3.0mm.
	Steering movement is hard.	Steering stem nut is excessively tightened.	Adjust steering stem nut correctly.	
		Steering stem bearings rollers have sticky movement/are rusted/ bearing is damaged/uneven seating.	Dismantle steering stem and replace bearings.	
	Vehicle met with an accident.	Fork main tube is bent.	Dismantle fork legs, check main tube for straightness and replace main tubes.	
		Fork end tubes are damaged.	Dismantle fork legs, check fork ends inside for excessive wear-out and replace.	
		Steering stem is bent.	Replace steering stem	
		Main frame is bent.	Check main frame for impact/bends and replace.	
2. REAR SHOCK ABSORBER/SWINGARM RELATED				
Rear suspension is noisy	Rear shock absorbers bushes are worn-out/ damaged.	Shock absorbers have excessive radial/axial play on top/bottom mounting bolts due to bush damage.	Replace both shock absorbers as a set.	
	Rear shock absorbers are misaligned.	Top/bottom mounting locations of shock absorbers are misaligned.	Check top and bottom mounting points for any misalignment. Replace swingarm if it is bent.	
	Rear swingarm bushes are defective.	Rear swingarm bushes are rusted/jammed.	Replace swingarm bushes and axle.	

Symptom	Possible Cause	Diagnosis	How to Fix	Recommended Specification
Rear suspension is too soft	Shock absorber spring is preloaded at Min position.	Rear shock absorber spring preload is adjusted to soft position.	Adjust shock absorber spring preload evenly on both LH and RH side for the desired riding comfort and road conditions.	
	Shock absorbers are weak.	Rear shock absorbers have oil leakage/springs are very soft.	Replace both shock absorbers as a set.	
	Rear swingarm bushes are defective.	Rear swingarm bushes are worn-out.	Replace swingarm bushes and axle.	
Rear suspension is too hard	Shock absorbers spring is preloaded at Max position.	Rear shock absorbers spring preload is adjusted to maximum hard position.	Adjust shock absorber spring preload evenly on both LH and RH side for desired riding comfort and road conditions.	
	Shock absorbers are defective.	Rear shock absorbers compression is very hard.	Replace both shock absorbers as a set.	
	Rear swingarm bushes are defective.	Rear swingarm bushes are rusted/jammed .	Replace swingarm bushes and axle.	
Rear tyre worn-out on one side	Rear shock absorbers spring preload adjustment is mismatching between LH and RH shock absorbers.	Spring preload adjustments are not at same position on LH & RH shock absorbers.	Adjust shock absorber spring preload evenly on both LH and RH side for desired riding comfort and road conditions.	
	Rear wheel bearings are defective.	Rear wheel bearings are worn-out/have excessive side play.	Replace wheel bearings.	
	Rear swingarm is defective.	Rear swingarm is bent (LH & RH arms not at same level).	Replace swingarm assembly.	
Vehicle skids when rear brake is applied	Wheels alignment is not proper.	Front and rear wheels are not aligned.	Align front and rear wheels.	
	Rear wheel bearings are defective.	Rear wheel bearings are worn-out/have excessive side play.	Replace wheel bearings.	
	Rear shock absorbers spring preload adjustment is mismatching between LH and RH shock absorbers.	Spring preload adjustments are not at same position on LH & RH shock absorbers.	Adjust shock absorber spring preload evenly on both LH and RH side for desired riding comfort and road conditions.	
	Rear swingarm bushes are defective.	Rear swingarm bushes are worn-out.	Replace swingarm bushes and axle.	
Rear swingarm has excessive side play	Rear swingarm mounting to frame is loose.	Rear swingarm axle nut is loose.	Check and correct swingarm alignment to frame and tighten swingarm mountings.	
	Rear swingarm bushes are defective	Rear swingarm bushes are rusted/jammed.	Replace swingarm bushes and axle.	

Symptom	Possible Cause	Diagnosis	How to Fix	Recommended Specification
3. TYRES RELATED				
Rear tyre is worn-out on one side.	Improper wheel alignment.	Rear wheel is misaligned with respect to front wheel.	Check and correct wheel alignment.	
Tyre wearing out unevenly/ vehicle is unstable/ wobbling	Internal defect/poor quality tyre.	Tyres found to have bulges/ cracks in side wall. Threads are separated from the tyre.	Replace with Royal Enfield recommended tyres.	Front tyre: Rear tyre:
	Tyre seating on rims is improper.	Tyre bead is uneven at the rim surface.	Remove tyre and reassemble correctly.	
	Wheel rims have a defect.	Wheel rims are bent/have excessive run-out.	Remove tyre. Carry out proper wheel truing.	
	Rims have excessive side play.	Wheel bearings are worn-out/have excessive play.	Remove and replace wheel bearings.	
4. WHEEL RIMS RELATED				
Vehicle is unstable/ wobbling	Tyre seating on rims is improper.	Tyre bead is uneven at the rim surface.	Remove tyre and reassemble correctly.	
	Wheel rims are out of trueness.	Wheel rims are bent/have excessive run-out.	Remove tyre and true the wheel rim correctly.	
	Wheel rims have a crack/heavy damage.	Wheel rims are cracked/ damaged due to impact.	Replace with Royal Enfield genuine wheel rims.	
	Wheels have excessive axial/side play.	Wheel bearings are worn-out.	Remove bearing and replace.	
	Hubs front/rear are cracked/damaged.	Wheel hubs are damaged due to impact.	Replace with Royal Enfield genuine hubs.	

SUBFRAME

Subframe

CONTENTS	PAGE
6.10 Subframe	267
Dismantling	267
6.10.1. RH Subframe	267
6.10.2. LH Subframe.....	268
6.10.3. Center Subframe	269
Assembly	270
6.10.4. Center Subframe	270
6.10.5. LH Subframe.....	270
6.10.6. RH Subframe	271

6.10 Subframe

Dismantling

6.10.1. RH Subframe

⚠ CAUTION

Ensure the motorcycle is upright on a firm and flat surface.

- Ensure ignition and stop switch are in off position.
- Remove the following parts:
 - Headlamp assembly and housing ([section 11.1](#)).
 - Trafficators front ([section 11.1.6](#)).
 - Instrument Cluster
- Remove two cap **(a)** from the RH subframe.

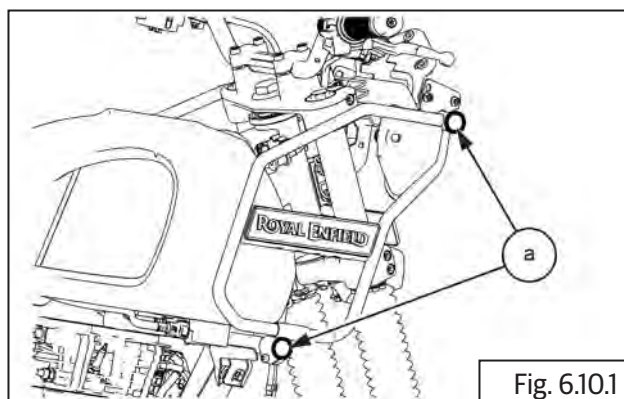

Screw Driver (-)

- Loosen and remove 1 No. allen bolt **(a)** from RH subframe near head lamp.

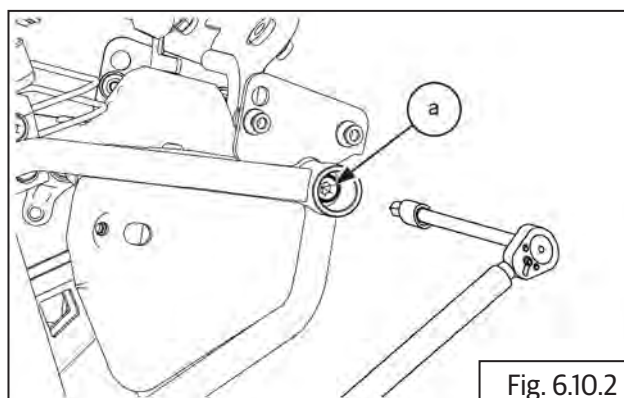

4 mm Allen socket with Ratchet

- Loosen and remove 1 No. allen bolt **(a)** from RH subframe near fuel tank.

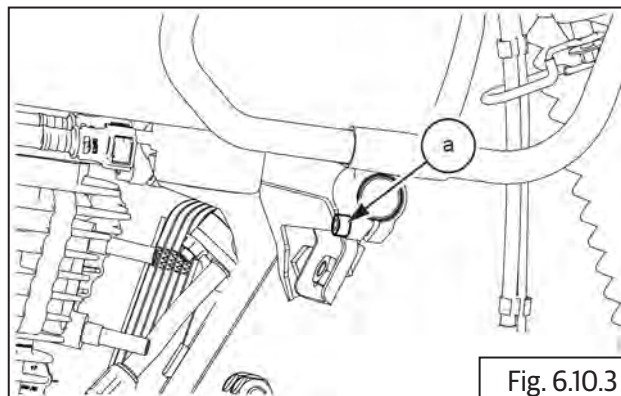

4 mm Allen socket with Ratchet

- Gently pull out RH trafficator cover **(a)** and remove from RH subframe.

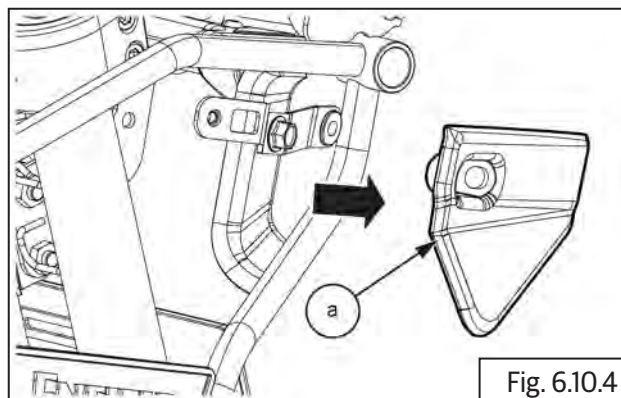

- Remove the 1 No. Hex mounting bolt **(a)** from the frame.

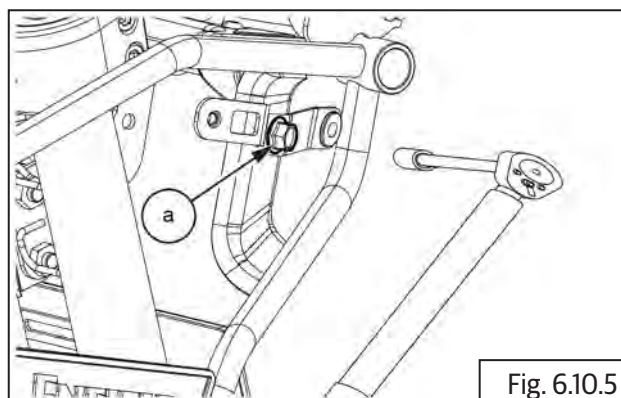

5mm Socket and Ratchet

- Gently pull and remove the RH subframe **(a)**.

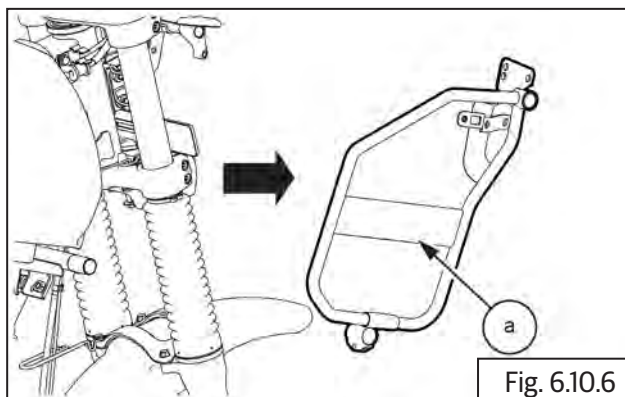

6.10.2. LH Subframe

- Remove two cap **(a)** from the LH subframe.

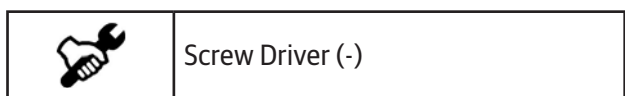
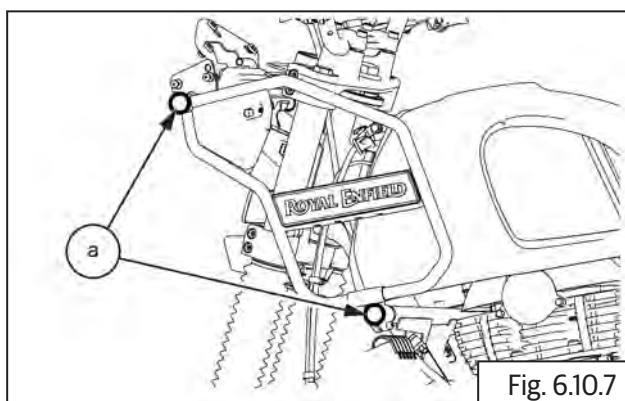

- Loosen and remove 1 No. allen bolt **(a)** from LH subframe near head lamp.

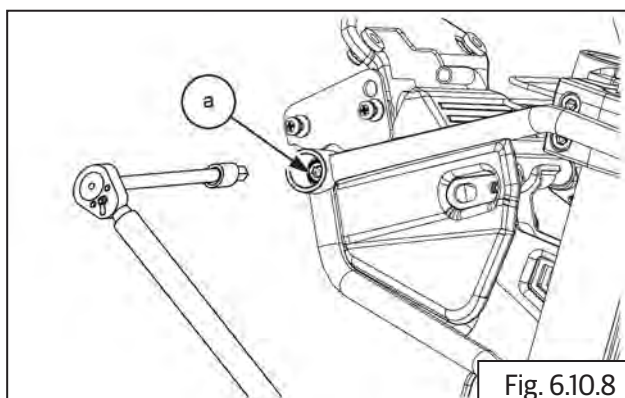

- Loosen and remove 1 No. allen bolt **(a)** from LH subframe near fuel tank.

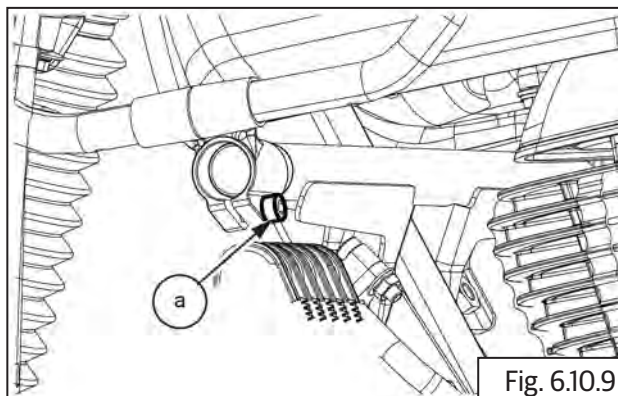

- Gently pull out RH trafficator cover **(a)** and remove from LH subframe.

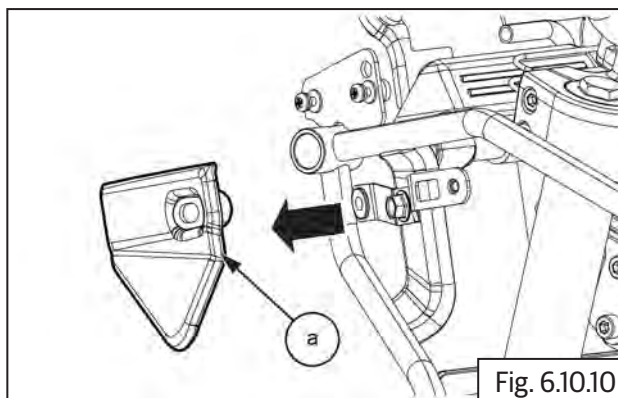

- Remove the 1 No. Hex mounting bolt **(a)** from the frame.

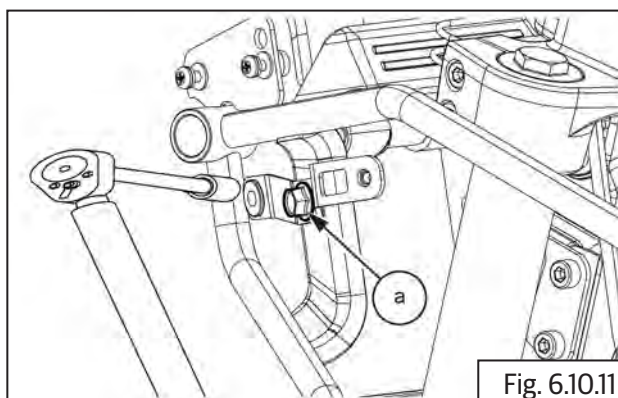

- Gently pull and remove the LH subframe **(a)**.

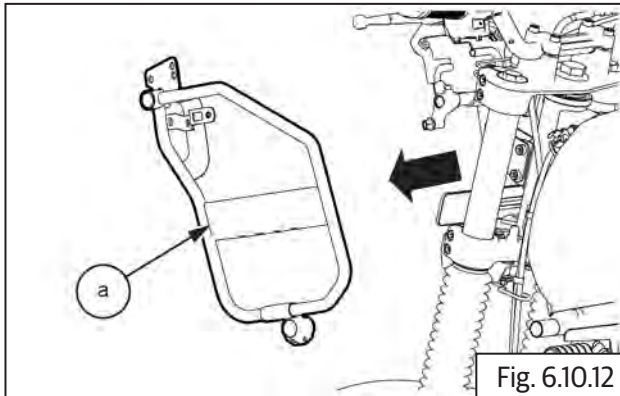

- Remove the 2 Nos. Allen bolts **(a)** by holding the nuts in the other side..

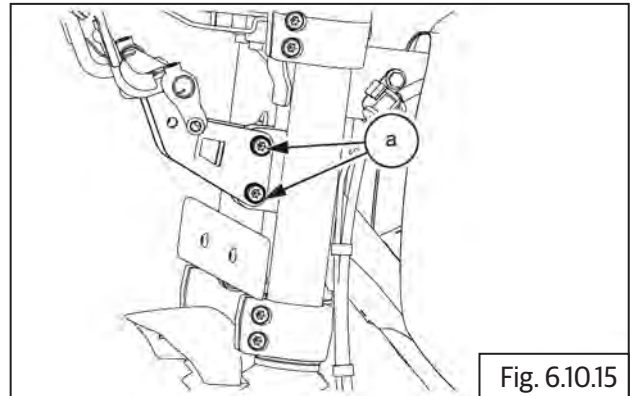

6.10.3. Center Subframe

- Loosen and remove 2 Nos. Phillip screws **(a)** from the instrument cluster cover.

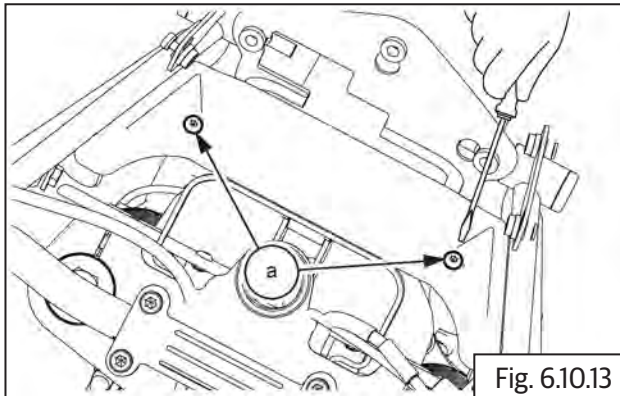

- Gently remove the instrument cluster cover **(a)** from the center subframe.

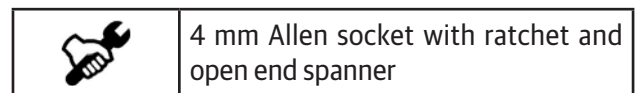
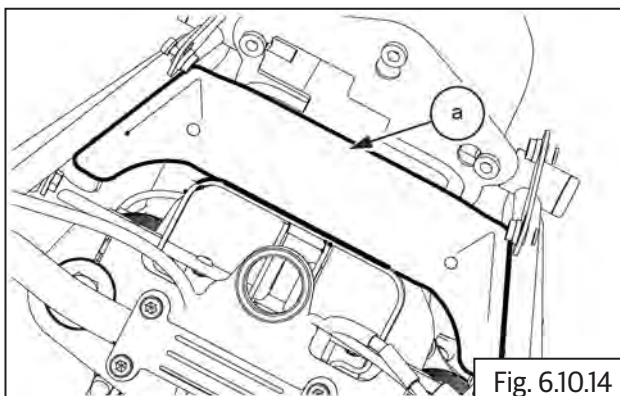

- Gently pull and remove the center subframe **(a)**.

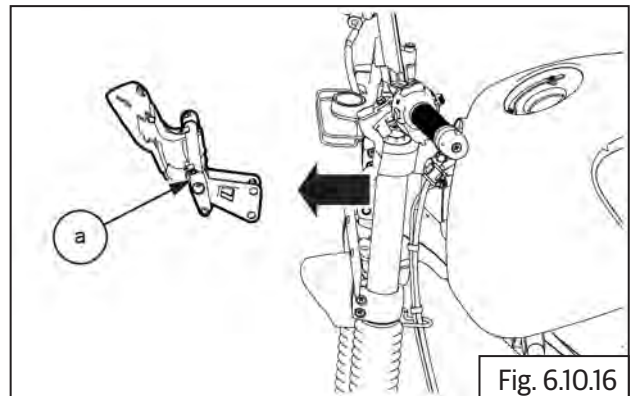

Assembly

6.10.4. Center Subframe

- Align the center subframe **(a)** to the mounting holes.

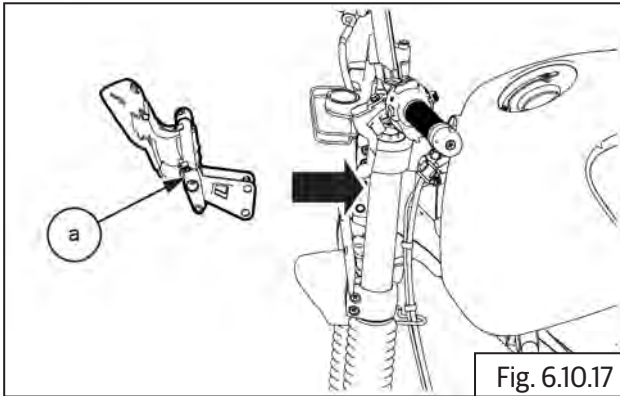

- Install 2 Nos. allen bolts **(a)** with two nuts on the frame..

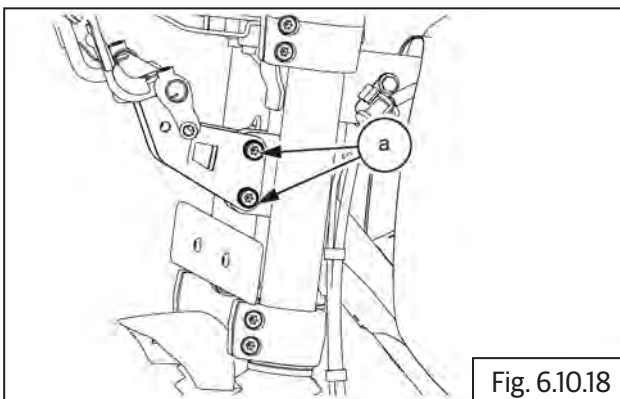

4 mm Allen socket with ratchet and open end spanner

- Locate the instrument cluster cover over the center subframe.

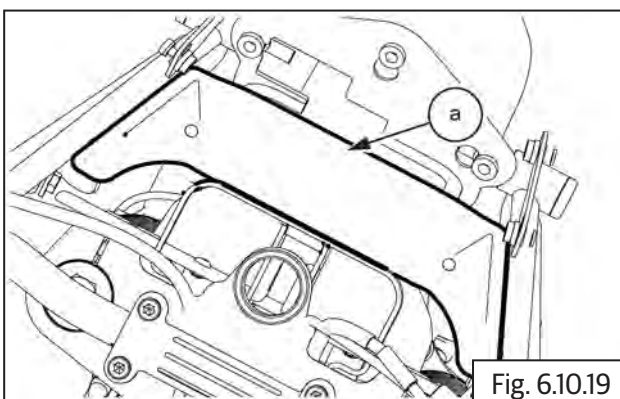

- Install 2 Nos. Phillip screws **(a)** on the instrument cluster cover.

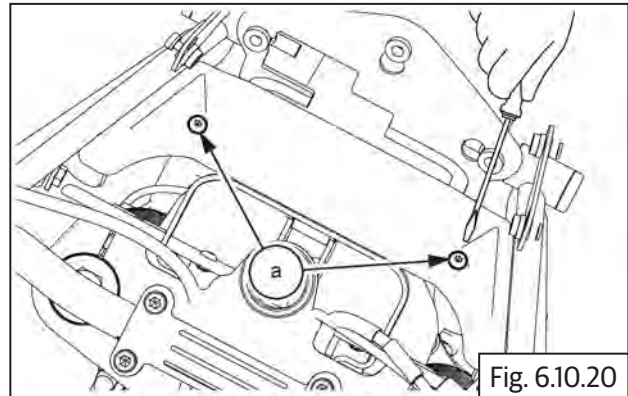

6.10.5. LH Subframe

- Align the LH subframe **(a)** to the mounting points.

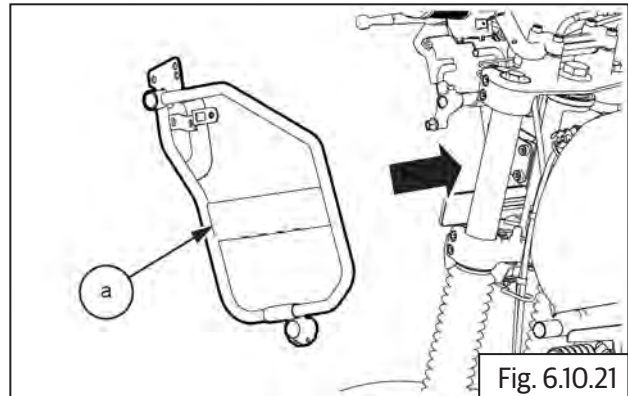

- Install 1 No. Hex mounting bolt **(a)** on the frame.

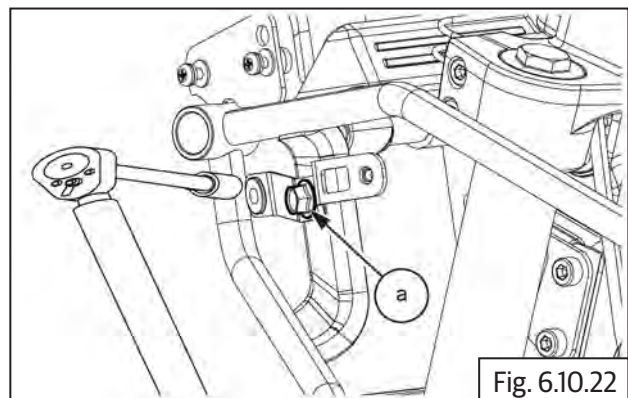

- Locate the LH trafficator cover **(a)** and Lock on LH subframe.

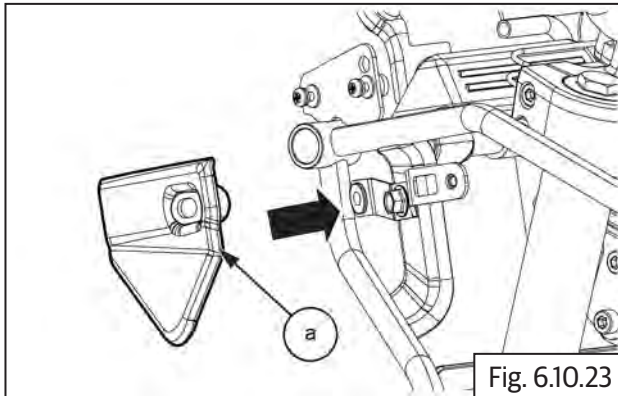

- Install the 1 No. Allen bolt **(a)** on LH subframe near fuel tank.

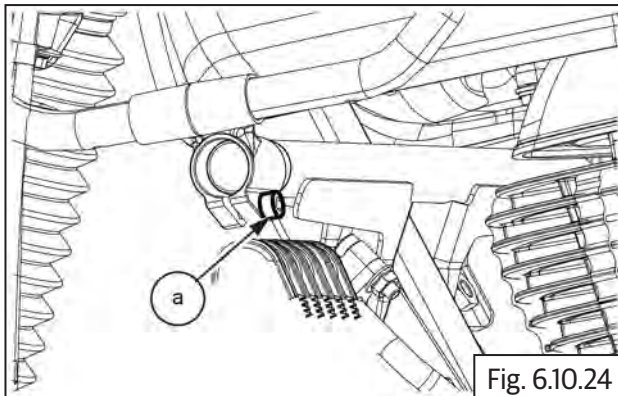

- Install 1 No. allen bolt **(a)** on LH subframe near head lamp.

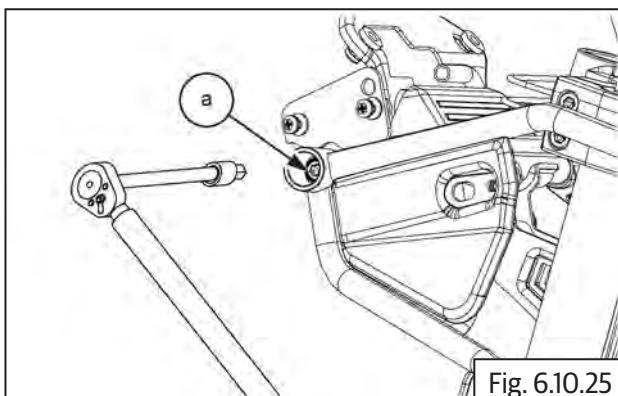

- Install two cap **(a)** to the LH subframe.

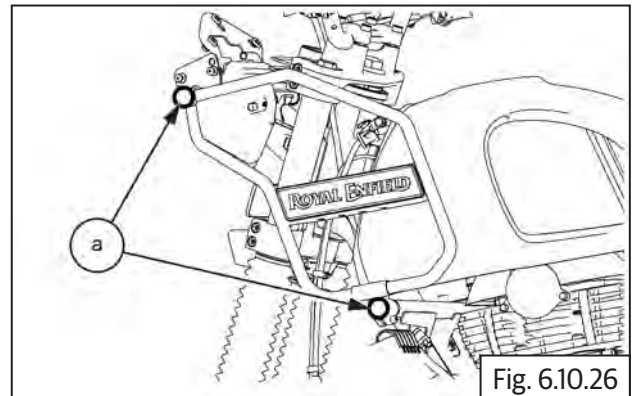

6.10.6. RH Subframe

- Align the RH subframe **(a)** to the mounting points.

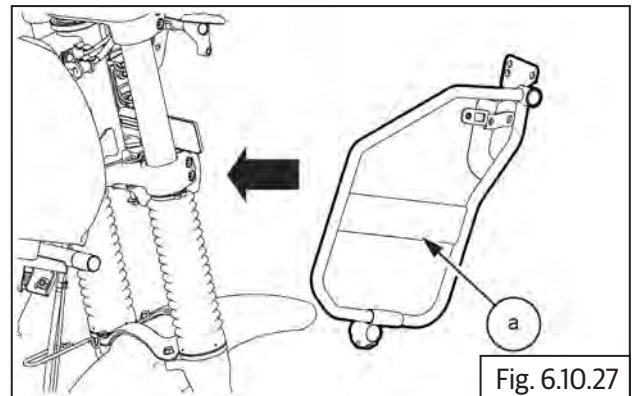

- Install 1 No. Hex mounting bolt **(a)** on the frame.

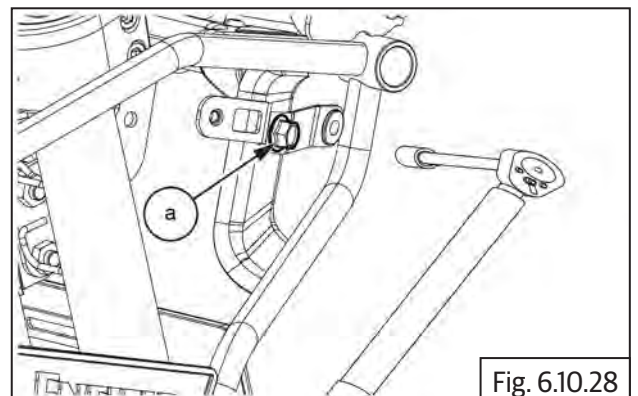

- Locate the RH trafficator cover **(a)** and Lock on LH subframe.

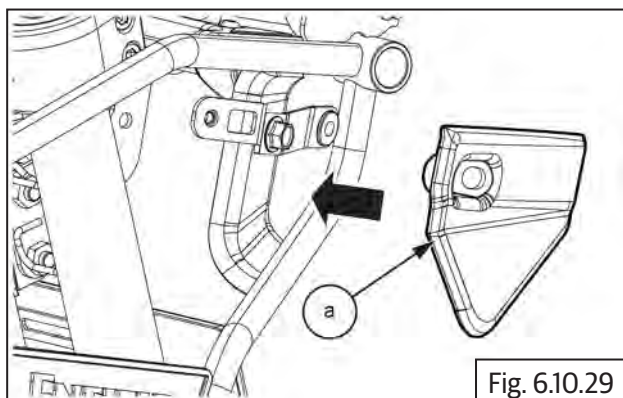

- Install two cap **(a)** to the RH subframe.

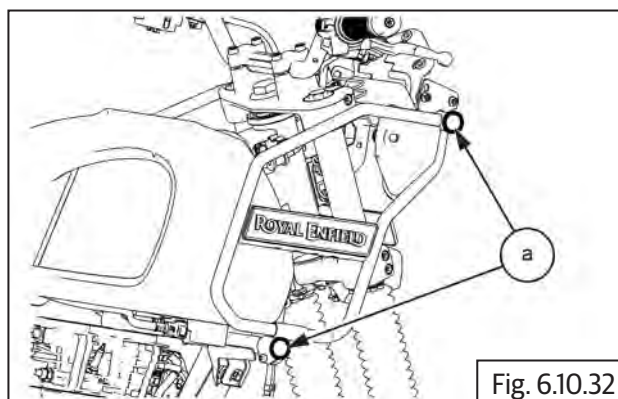

- Install the 1 No. Allen bolt **(a)** on RH subframe near fuel tank.

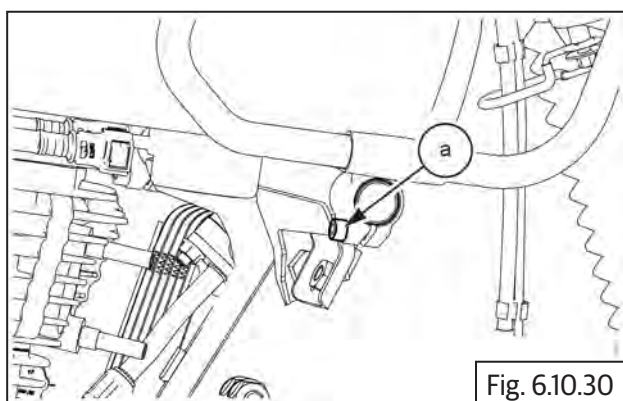

4 mm Allen socket with Ratchet

- Install 1 No. allen bolt **(a)** on RH subframe near head lamp.

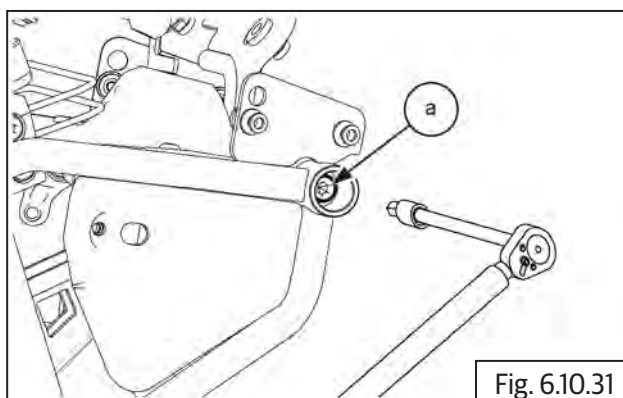

4 mm Allen socket with Ratchet

VEHICLE TROUBLESHOOTING

Vehicle Troubleshooting

CONTENTS	PAGE
6.11. Troubleshooting	275
6.11.1. Air Filter	275
6.11.2. Control Cables	276
6.11.3. Handlebar	278
6.11.4. Exhaust Pipes and Silencers	279
6.11.5. Wheels	280
6.11.6. Suspension	282

6.11. Troubleshooting

6.11.1. Air Filter

Symptom	Possible Cause	Diagnosis	How to Fix	Recommended Specification
Air induction noise from air filter box is high	Air filter element cover not sealing properly on air filter box assembly	Air filter element cover not seated properly on air filter box assembly/ improperly tightened	Check proper seating of the air filter element cover on air filter box assembly	
	Air filter element cover cracked	Air filter element cover cracked due to improper assembly/over tightened	Replace air filter box assembly	
	Air filter box assembly cracked/damaged	Air filter box assembly not aligned properly and tightened/damaged due to damage	Replace air filter box assembly	
	Hoses connecting to inlet manifold cracked	Cracked due to age hardening/improper assembly	Replace hosesjj	
Engine running very sluggish and pick up poor	Filter element choked	Filter element choked with dirt/water/oil	Check and replace filter element	
Engine misfiring/ running lean/idling improper	Rubber hoses connecting from air filter box assembly to acv, iac, throttle body, cracked/disconnected/ not sealing properly	Check and inspect each hose for no damage/ cracks/proper fitting	Check and replace hose/s, and/or air filter body as required	
	Filter element damaged	Damaged due to mishandling/heavy particles entering air filter box assembly	Check and replace filter element	
	Iat sensor not sealing properly	Iat sensor sealing gasket damaged/mounting screws loose	Check and replace iat sensor gasket/sensor	
	Acv not sealing properly	Acv sealing gasket damaged/mounting screws loose	Check and replace acv gasket/sensor	
Engine oil accumulation inside air filter box assembly	Excessive oil in sump	Check and maintain correct engine oil level	Clean breather chamber and hose leading to air filter box assembly	

6.11.2. Control Cables

Symptom	Possible Cause	Diagnosis	How to Fix	Recommended Specification
Clutch lever movement not smooth	Clutch lever operation at is sticky	Clutch lever, bracket and pivot screw at handlebar end is dry without lubrication/excessive dirt accumulation	Clean and lubricate clutch lever, bracket and pivot screw at handlebar end	
	Clutch lever excessive movement in handlebar bracket LH	Clutch lever mounting hole is out of shape/fixing bolt worn-out	Check and replace clutch lever bracket assembly	
	Inner cable movement sticky	Inner cable strands broken and jammed inside outer cable/clutch lever bracket	Check and replace clutch cable	
		Teflon tube inside outer cable torn/damaged	Check and replace clutch cable	
	Clutch shaft movement sticky in cover RH	Poor/no lubrication of the clutch shaft in cover RH/ uneven wear-out of clutch shaft/cover RH	Check and replace clutch shaft/cover RH	
	Clutch plates movement in clutch housing is sticky	Clutch plates/clutch housing damaged	Check and replace clutch plates/clutch assembly	

Symptom	Possible Cause	Diagnosis	How to Fix	Recommended Specification
Clutch operation hard	Clutch lever movement in bracket hard	Clutch lever, bracket and pivot screw at handlebar end is dry without lubrication/excessive dirt accumulation	Clean and lubricate clutch lever, bracket and pivot screw at handlebar end	
	Inner cable movement sticky in outer cable	Inner cable strands broken and jammed inside outer cable/clutch lever bracket	Check and replace clutch cable	
		Teflon tube inside outer cable torn/damaged	Check and replace clutch cable	
	Clutch shaft movement hard in cover RH	Poor/no lubrication of the clutch shaft in cover RH/uneven wear-out of clutch shaft/cover RH	Check and replace clutch shaft/cover RH	
	Clutch plates burnt and hard	Clutch plates burnt/hard/clutch housing damaged	Check and replace clutch plates/clutch assembly	
Throttle rotor movement sticky/opening hard	Throttle cables are stuck between frame and fuel tank	Throttle cables stuck/jammed between frame and fuel tank	Check cable routing and proper strapping to frame	
	Throttle rotor movement in housing is sticky	Throttle rotor area in the housing is dry/heavy dirt accumulation	Check and lubricate throttle rotor and housing in handlebar	
	Throttle rotor cable seating area damaged	The eyelets in the throttle rotor are damaged/inner cable eyelets not seating correctly in the rotor eyelets	Check and replace throttle cables/throttle rotor	
	Inner cables movement sticky in outer cable	Throttle cables inner strands broken	Check and replace throttle cables	
		Teflon coating in between inner/outer throttle cables damaged		

6.11.3. Handlebar

Symptom	Possible Cause	Diagnosis	How to Fix	Recommended Specification
Vibrations transmitted to rider while riding	Tyre pressures are more than recommended.	Improper front and rear tyre pressures.	Ensure correct tyre pressures.	Solo: Front tyre: 32 psi/2.2 kg/cm ² . Rear tyre: 32 psi/2.2 kg/cm ² . With Pillion: Front tyre: 32 psi/2.2 kg/cm ² . Rear Tyre: 36 psi/2.54 kg/cm ² .
	Handlebar balancers are loose.	Balancer mountings are loose/threads are worn-out.	Tighten balancer mountings/replace balancers.	
	Handlebar clamp fasteners are loose on top yoke.	Fasteners loose/threads worn-out	Check and tighten fasteners/replace fasteners/handlebar clip-ons/top yoke	
	Handlebar is cracked at mounting location.	Clip-on/handlebar clamping locations has minor cracks.	Replace clip-ons/handlebar	
Uneasiness/pain felt on one shoulder	Handlebar is bent/misaligned.	One or the other clip-on is bent/handlebar is bent. Handlebar alignment dots are not correct.	Replace clip-ons/handlebar. Ensure correct positioning of the handlebar alignment dots with respect to top yoke.	

6.11.4. Exhaust Pipes and Silencers

Symptom	Possible Cause	Diagnosis	How to Fix	Recommended Specification
Vibration/rattling noise from exhaust pipe/s.	Exhaust pipe mounting to cylinder head is loose.	Exhaust pipe flange mounting to cylinder head is loose/flange is cracked.	Check and tighten flange mounting to torque. Replace exhaust pipe if flange is cracked.	Torque: 25-35 N-m/2.5-3.5 kgf-m
	Exhaust pipe mounting to frame is loose.	Fasteners are loose/mounting clamps are cracked.	Check and tighten fasteners to torque. Replace clamps if they are cracked.	Torque: 25-35 N-m/2.5-3.5 kgf-m
Vibration/rattling noise from silencer/s.	Silencer mounting to frame is loose.	Fasteners are loose/mounting clamps are cracked.	Check and tighten fasteners to torque. Replace clamps/silencer if they are cracked.	Torque: 25-35 N-m/2.5-3.5 kgf-m
	Internal baffles in silencer are broken.	Remove silencer and shake to check if internal baffles are cracked.	Replace silencer assembly.	
Exhaust leak from cylinder head joint/silencer joint.	Gaskets are burnt/missing.	Gaskets are burnt-out due to loose clamping of exhaust pipe/silencer.	Replace exhaust pipe/silencer gasket.	

6.11.5. Wheels

Symptom	Possible Cause	Diagnosis	How to Fix	Recommended Specification
1. Tyres Related				
Centre Threads Wear-Out Is High/ Poor Traction/ Unstable Riding	Tyre pressure is more than recommended.	Front and rear tyre pressure is over inflated.	Ensure correct tyre pressures.	Front tyre: 32 psi/2.2 kg/cm ² . Rear tyre: Solo: 32 psi/2.2 kg/cm ² With Pillion: 36 psi/2.54 kg/cm ² .
Side Threads Wear-Out Is High/Side Wall Has Cracks/ Motorcycle Has Dragging/Unstable Riding	Tyre pressures is less than recommended.	Front and rear tyre pressures under inflated side walls have minute cracks.	Check inner tubes for any puncture/leaky valve pins ensure correct tyre pressures.	Front tyre: 32 psi/2.2 kg/cm ² . Rear tyre: Solo: 32 psi/2.2 kg/cm ² . With Pillion: 36 psi/2.54 kg/cm ² .
Rear Tyre Wear-Out On One Side	Improper wheel alignment.	Rear wheel misaligned with respect to front wheel.	Check and correct wheel alignment.	
Tyre/S Wearing Out Is Uneven/ Motorcycle Is Unstable/Wobbling	Internal defect/poor quality tyre.	Tyres found to have bulges/cracks in side wall. Threads are separated from the tyre.	Replace with Royal Enfield recommended tyres.	Front tyre: 100/90-19, Rear tyre: 140/70-17,
	Tyre seating on rims is improper.	Tyre bead is uneven at the rim surface.	Remove tyre and reset correctly.	
	Wheel rims have a defect.	Wheel rims are bent/ have excessive run-out.	Remove tyre and carry out proper wheel truing.	
	Rims have excessive side play.	Wheel bearings worn-out/excessive play.	Remove and replace wheel bearings.	

Symptom	Possible Cause	Diagnosis	How to Fix	Recommended Specification
2. Wheel Rims Related				
Motorcycle Is unstable/Wobbling	Tyre seating on rims is improper	Tyre bead is uneven at the rim surface	Remove tyre and reset correctly	
	Wheel rims are out of trueness	Wheel rims are bent/ have excessive run-out	Remove tyre and true the wheel rim correctly	
	Wheel rims have a crack/heavy damage	Wheel rims are cracked/damaged due to impact	Replace with royal enfield genuine wheel rims	
3. Others				
Motorcycle Is unstable/Wobbling	Wheels have excessive axial/side play	Wheel bearings are worn-out	Remove bearing and replace	

6.11.6. Suspension

Symptom	Possible Cause	Diagnosis	How to Fix	Recommended Specification
1. Front Fork/Steering Stem Related				
Oil leak from fork assembly LH/RH	Excessive oil is filled.	Excessive oil is filled in fork legs.	Dismantle fork legs, drain oil and fill correct recommended oil quantity.	Royal Enfield front fork oil 2W 25. Quantity 473 ml/ fork.
	Oil leaks from top cap nut.	Cap nuts are loose/sealing washer is damaged.	Tighten Cap nuts/replace sealing washer.	
	Oil leaks between main tube and guide tube is faulty.	Oil seals are worn-out or not seated evenly/loose in guide tubes.	Dismantle fork legs and replace oil seals.	
	Oil leaks from guide tube bottom.	Oil leaks from Hex socket bolt at the bottom of guide tube.	Dismantle fork legs and replace sealing washer bottom and reassemble.	
Hitting noise from front fork/s	Oil quantity is less in one/both fork legs.	Oil quantity mismatched between LH and RH fork assemblies.	Dismantle fork legs, drain oil and fill with correct recommended quantity.	Royal Enfield front fork oil 2W 25. Quantity 473 ml/ fork.
	Fork main springs have become soft/ coils are broken/ length is reduced.	Fork main springs have lost tension/Overall length of the main springs is reduced/coils are broken.	Dismantle fork legs and replace fork main springs.	Main spring length: 303 ± 3.0mm.
	Rebound spring has become soft/broken/ length is reduced.	Rebound springs have lost tension/overall length is reduced/coils are broken.	Dismantle fork legs and replace rebound springs.	
	Taper oil lock is not seated properly/is loose on piston tube.	Taper oil lock is seated unevenly/loose in piston tube/hex socket bolt at fork end bottom is loose.	Dismantle fork leg assemblies, check for uneven seating/loose fittings and replace taper oil lock/fork piston assembly.	
Fork action is soft	Oil quantity is less in one/both fork legs.	Oil quantity mismatched between LH and RH fork assemblies.	Dismantle fork legs, drain out oil and fill with correct recommended quantity.	Royal Enfield front fork oil 2W 25. Quantity 473 ml/ fork.
	Fork main springs are soft/coils are broken/ length is reduced.	Fork main springs have lost tension/overall length of main springs is reduced/coils are broken.	Dismantle fork legs and replace fork main springs.	Main spring length: 303 ± 3.0mm.

Symptom	Possible Cause	Diagnosis	How to Fix	Recommended Specification
Fork action is hard	Excessive oil is filled in fork assembly LH/RH.	Excessive oil is filled in the fork legs.	Dismantle fork legs, drain oil and fill with correct recommended quantity.	Royal Enfield front fork oil 2W 25. Quantity 473 ml/ fork.
	Fork main tube movement in fork ends is sticky.	Fork main tube is bent.	Dismantle fork legs, check main tube for straightness and replace main tubes.	
		Fork end tubes are damaged.	Dismantle fork legs, check fork ends inside for excessive wear-out.	
Riding is unstable	Tyre seating on rims is improper.	Tyre bead is uneven at the rim surface.	Remove tyre and reassemble correctly.	
	Wheel rims are out of trueness.	Wheel rims are bent/have excessive run-out.	Remove tyre and true the wheel rim correctly.	
	Wheel rims have a crack/heavy damage.	Wheel rims have been cracked/damaged due to impact.	Replace with Royal Enfield genuine wheel rims.	
	Wheels have excessive axial/side play.	Wheel bearings are worn-out	Remove bearing and replace	
	Hubs front/rear are cracked/damaged	Wheel hubs are damaged due to impact.	Replace with Royal Enfield genuine hubs.	
	Oil quantity is mismatching in LH and RH fork legs.	Oil quantity mismatched between LH and RH fork assemblies.	Dismantle fork legs, drain oil and fill with correct recommended quantity.	Royal Enfield front fork oil 2W 25. Quantity 473 ml/ fork.
	Fork main springs have become soft/ coils are broken/ length is reduced.	Fork main springs have lost tension/Overall length of the main springs is reduced/coils are broken.	Dismantle fork legs and replace fork main springs.	Main spring length: 303 ± 3.0mm.
	Fork main tube movement in fork end is sticky.	Fork main tube is bent.	Dismantle fork legs, check main tube for straightness and replace main tubes.	
		Fork end tubes are damaged.	Dismantle fork legs, check fork ends inside for excessive wear-out and replace.	
	Steering stem movement is not smooth.	Control cables/wiring harness is not routed properly.	Route the control cables/ wiring harness correctly and strap to frame.	
		Steering stem nut is excessively tightened.	Adjust the steering stem nut correctly.	
		Steering stem bearings rollers have sticky movement/is rusted/bearing is damaged/uneven seating.	Dismantle steering stem and replace bearings.	
	Steering stem is bent.	Steering stem is bent.	Replace steering stem.	

Symptom	Possible Cause	Diagnosis	How to Fix	Recommended Specification
Vehicle is pulling to one side	Tyre pressures are less/more than recommended.	Front and rear tyre pressures are under/over inflated.	Ensure correct tyre pressures.	Solo: Front tyre: 32 psi/2.2 kg/cm ² . Rear tyre: 32 psi/2.2 kg/cm ² . With Pillion: Front tyre: 32 psi/2.2 kg/cm ² . Rear Tyre: 36 psi/2.54 kg/cm ² .
	Wheels alignment is not proper.	Front and rear wheels are not aligned.	Align front and rear wheels correctly.	
	Oil quantity is mismatching in LH and RH fork legs.	Oil quantity is mismatched between LH and RH fork assemblies.	Dismantle fork legs, drain out the oil and fill with correct recommended quantity.	Royal Enfield front fork oil 2W 25. Quantity 473 ml/ fork.
	Fork main springs have become soft/ coils are broken/ length is reduced.	Fork main springs have lost tension/Overall length of the main springs is reduced/coils are broken.	Dismantle fork legs and replace fork main springs.	Main spring length: 303 ± 3.0mm.
	Steering movement is hard.	Steering stem nut is excessively tightened.	Adjust steering stem nut correctly.	
		Steering stem bearings rollers have sticky movement/are rusted/ bearing is damaged/uneven seating.	Dismantle steering stem and replace bearings.	
	In case of vehicle met with an accident.	Fork main tube is bent.	Dismantle fork legs, check main tube for straightness and replace main tubes.	
		Fork end tubes are damaged.	Dismantle fork legs, check fork ends inside for excessive wear-out and replace.	
		Steering stem is bent.	Replace steering stem	
		Main frame is bent.	Check main frame for impact/bends and replace.	

2. Rear Shock Absorber/Swingarm Related

Rear suspension is noisy	Rear shock absorbers bushes are worn-out/ damaged.	Shock absorbers have excessive radial/axial play on top/bottom mounting bolts due to bush damage.	Replace both shock absorbers as a set.	
	Rear shock absorbers are misaligned.	Top/bottom mounting locations of shock absorbers are misaligned.	Check top and bottom mounting points for any misalignment. Replace swingarm if it is bent.	
	Rear swingarm bushes are defective.	Rear swingarm bushes are rusted/jammed.	Replace swingarm bushes and axle.	

Symptom	Possible Cause	Diagnosis	How to Fix	Recommended Specification
Rear suspension is too soft	Shock absorber spring is preloaded at Min position.	Rear shock absorber spring preload is adjusted to soft position.	Adjust shock absorber spring preload evenly on both LH and RH side for the desired riding comfort and road conditions.	
	Shock absorbers are weak.	Rear shock absorbers have oil leakage/springs are very soft.	Replace both shock absorbers as a set.	
	Rear swingarm bushes are defective.	Rear swingarm bushes are worn-out.	Replace swingarm bushes and axle.	
Rear suspension is too hard	Shock absorbers spring is preloaded at Max position.	Rear shock absorbers spring preload is adjusted to maximum hard position.	Adjust shock absorber spring preload evenly on both LH and RH side for desired riding comfort and road conditions.	
	Shock absorbers are defective.	Rear shock absorbers compression is very hard.	Replace both shock absorbers as a set.	
	Rear swingarm bushes are defective.	Rear swingarm bushes are rusted/jammed .	Replace swingarm bushes and axle.	
Rear tyre worn-out on one side	Rear shock absorbers spring preload adjustment is mismatching between LH and RH shock absorbers.	Spring preload adjustments are not at same position on LH & RH sock absorbers.	Adjust shock absorber spring preload evenly on both LH and RH side for desired riding comfort and road conditions.	
	Rear wheel bearings are defective.	Rear wheel bearings are worn-out/have excessive side play.	Replace wheel bearings.	
	Rear swingarm is defective.	Rear swingarm is bent (LH & RH arms not at same level).	Replace swingarm assembly.	
Vehicle skids when rear brake is applied	Wheels alignment is not proper.	Front and rear wheels are not aligned.	Align front and rear wheels.	
	Rear wheel bearings are defective.	Rear wheel bearings are worn-out/have excessive side play.	Replace wheel bearings.	
	Rear shock absorbers spring preload adjustment is mismatching between LH and RH shock absorbers.	Spring preload adjustments are not at same position on LH & RH sock absorbers.	Adjust shock absorber spring preload evenly on both LH and RH side for desired riding comfort and road conditions.	
	Rear swingarm bushes are defective.	Rear swingarm bushes are worn-out.	Replace swingarm bushes and axle.	
	Rear swingarm is defective/rubbing on frame on one side.	Rear swingarm is bent (LH & RH arms are not at same level).	Replace swingarm assembly.	
Rear swingarm has excessive side play	Rear swingarm mounting to frame is loose.	Rear swingarm axle nut is loose.	Check and correct swingarm alignment to frame and tighten swingarm mountings.	
	Rear swingarm bushes are defective	Rear swingarm bushes are rusted/jammed.	Replace swingarm bushes and axle.	

Symptom	Possible Cause	Diagnosis	How to Fix	Recommended Specification
3. Tyres Related				
Rear tyre is worn-out on one side.	Improper wheel alignment.	Rear wheel is misaligned with respect to front wheel.	Check and correct wheel alignment.	
Tyre/s wearing out unevenly/ vehicle is unstable/ wobbling	Internal defect/poor quality tyre.	Tyres found to have bulges/ cracks in side wall. Threads are separated from the tyre.	Replace with Royal Enfield recommended tyres.	Front tyre: 100/90-19 Rear tyre: 140/70-17
	Tyre seating on rims is improper.	Tyre bead is uneven at the rim surface.	Remove tyre and reassemble correctly.	
	Wheel rims have a defect.	Wheel rims are bent/have excessive run-out.	Remove tyre. Carry out proper wheel truing.	
	Rims have excessive side play.	Wheel bearings are worn-out/have excessive play.	Remove and replace wheel bearings.	
4. Wheel Rims Related				
Vehicle is unstable/ wobbling	Tyre seating on rims is improper.	Tyre bead is uneven at the rim surface.	Remove tyre and reassemble correctly.	
	Wheel rims are out of trueness.	Wheel rims are bent/have excessive run-out.	Remove tyre and true the wheel rim correctly.	
	Wheel rims have a crack/heavy damage.	Wheel rims are cracked/damaged due to impact.	Replace with Royal Enfield genuine wheel rims.	
	Wheels have excessive axial/side play.	Wheel bearings are worn-out.	Remove bearing and replace.	
	Hubs front/rear are cracked/damaged.	Wheel hubs are damaged due to impact.	Replace with Royal Enfield genuine Wheels.	

FUEL SYSTEM

CONTENTS	PAGE
7.1. Fuel System Components.....	289
Dismantling.....	289
7.1.1. Fuel Tank.....	289
7.1.2. Fuel Pump Connector and Fuel Level Sensor	289
7.1.3. Fuel Hose (Fuel Pump to Injector)	289
7.1.4. EVAP Connections to Fuel Tank.....	290
7.1.5. Drain Hose	290
7.1.7. Fuel Pump	290
7.1.6. Fuel Level Sensor.....	291
7.1.6. Fuel Float	291
Inspection	292
7.1.9. Fuel Float	292
7.1.10. Fuel Pump	292
7.1.11. Fuel Filter.....	292
Assembly	293
7.1.12.....	Fuel
Float	293
7.1.13.....	Fuel
Level Sensor.....	293
7.1.14.	Fuel
Pump	293
7.1.15. Fuel Tank.....	294
7.1.16. Drain Hose.....	294
7.1.17. EVAP Connections to Fuel Tank	294
7.1.18. Fuel Hose (Fuel Pump to Injector).....	294
7.1.19. Fuel Pump Connector.....	295

7.1. Fuel System Components

⚠ WARNING

Gasoline is extremely flammable and highly explosive. Please handle with care. Improper handling can lead to fatal accident or serious injury. Always drain/fill fuel only in a well ventilated area.

Ensure there is no scope for flames or sparks near by while draining/filling fuel.

⚠ CAUTION

Make sure the fuel pressure is relieved before disconnecting the fuel connection.

⚠ CAUTION

Ensure the motorcycle is upright on a firm and flat surface.

Dismantling

7.1.1. Fuel Tank

- Ensure the ignition and stop switches are in OFF position.
- Remove the fuel tank cap. Drain fuel completely from fuel tank.
- Remove seat assembly
- Loosen and remove 2 Nos. Hex head bolts (M6) (a) from rear end of fuel tank on frame (b).

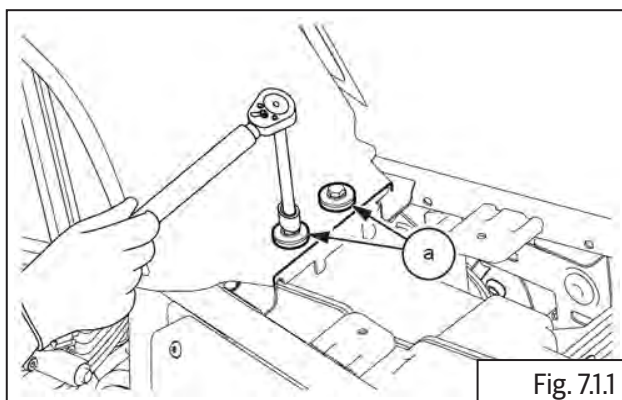

Fig. 7.1.1



10 mm Socket with Ratchet

7.1.2. Fuel Pump Connector and Fuel Level Sensor

- Gently lift fuel tank (a) upwards and pull backwards slightly.
- Disconnect fuel pump connector (b) from fuel tank.

⚠ CAUTION

DO NOT lift the tank too much to prevent damage to connectors and brake hoses.

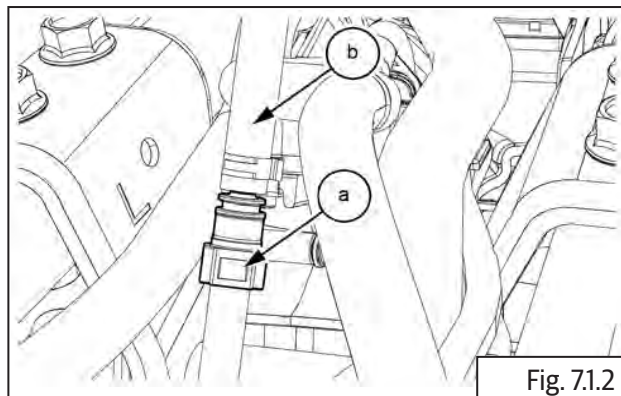

Fig. 7.1.2

7.1.3. Fuel Hose (Fuel Pump to Injector)

- Clean quick fix adapter area and disconnect by pressing lock button. Remove fuel hose (a).

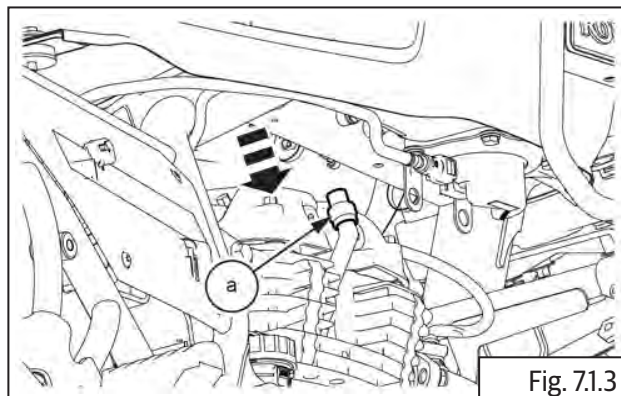
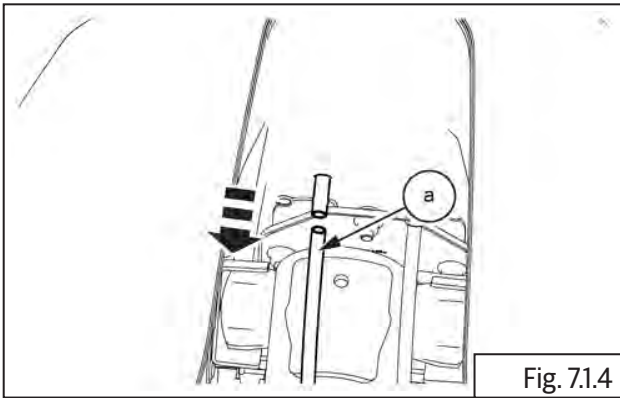

Fig. 7.1.3

71.4. EVAP Connections to Fuel Tank

- Disconnect EVAP connection hose **(a)** from fuel tank.



71.5. Drain Hose

- Disconnect drain hose connection **(a)** from fuel tank **(b)**.

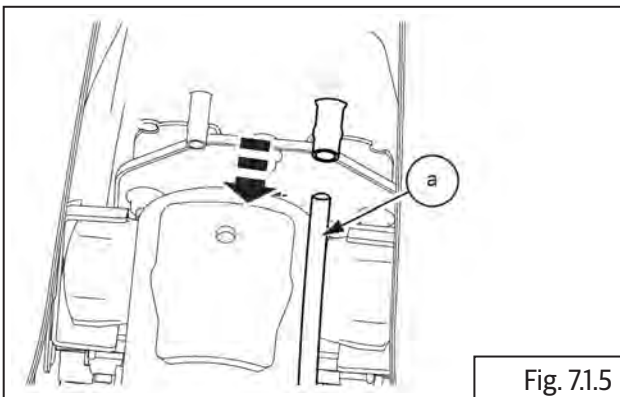

- Gently remove fuel tank **(a)** from frame.

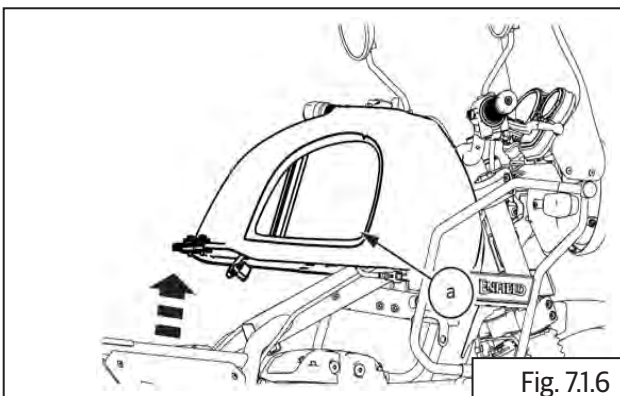

71.7. Fuel Pump

- Loosen and remove 4 Nos. Hex socket head bolts **(M6)** **(a)** holding fuel pump **(b)** to tank **(c)**.

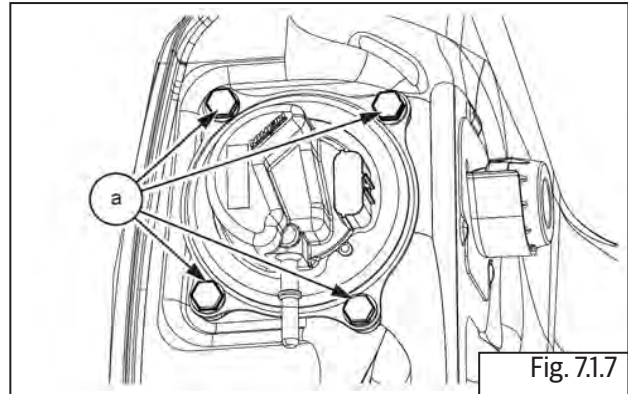

10 mm Socket with Ratchet

- Gently pull out the fuel pump **(a)** from fuel tank **(b)**.

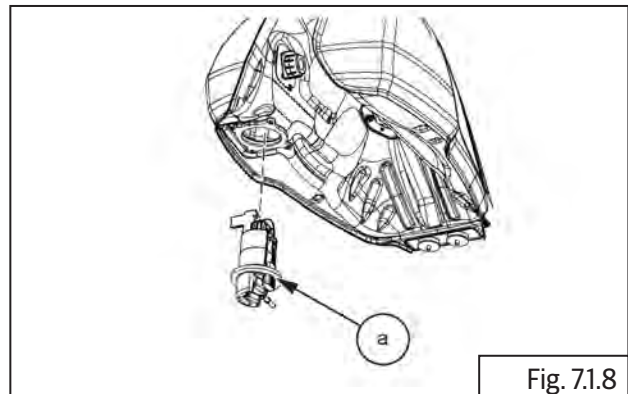

- Remove O-rings **(a)** and head cover **(b)** from fuel pump **(c)**.

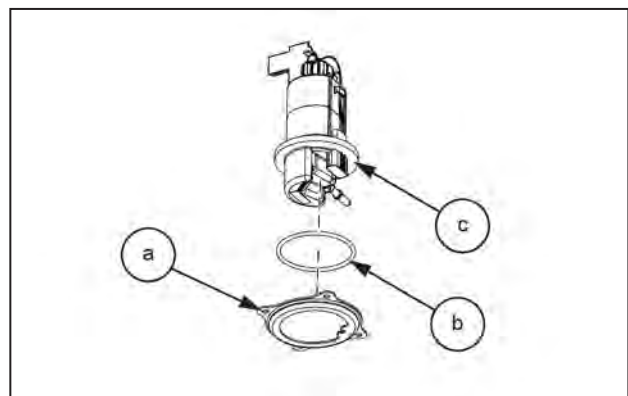

7.1.6. Fuel Level Sensor

- Lift connector lock **(a)** and remove the coupler **(b)**.

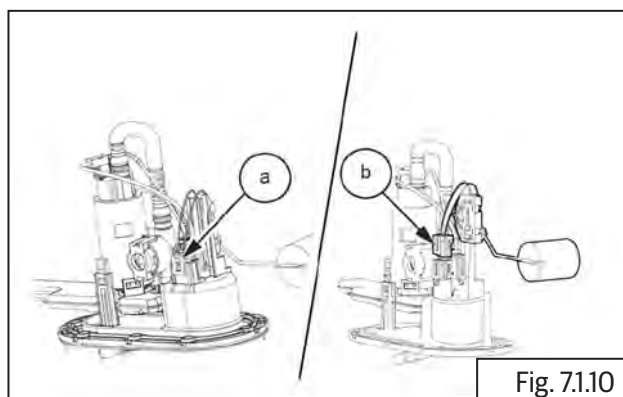

Fig. 7.1.10

- Gently remove the coupler **(a)** from module **(b)**.

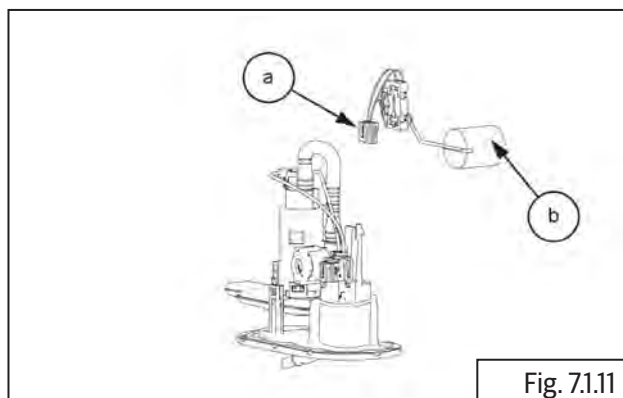

Fig. 7.1.11

- Remove the fuel level sensor **(a)**

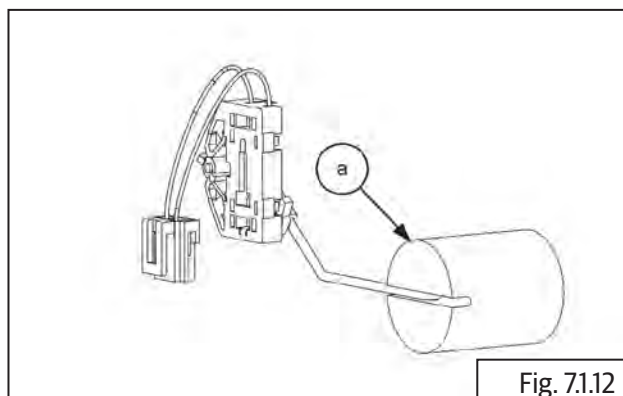

Fig. 7.1.12

7.1.6. Fuel Float

- Remove 4 Nos. nut **(a)** from the module.

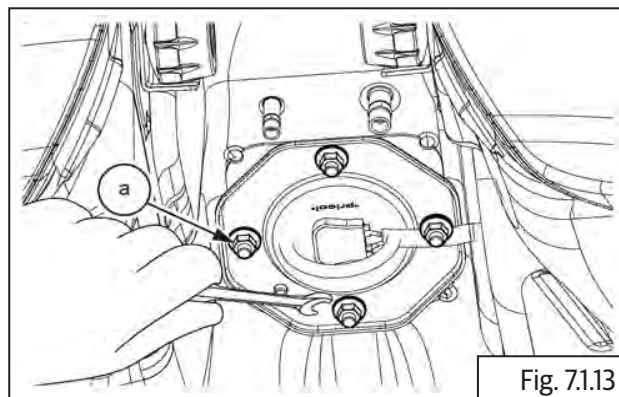

Fig. 7.1.13

- Gently remove the fuel pump **(a)**.

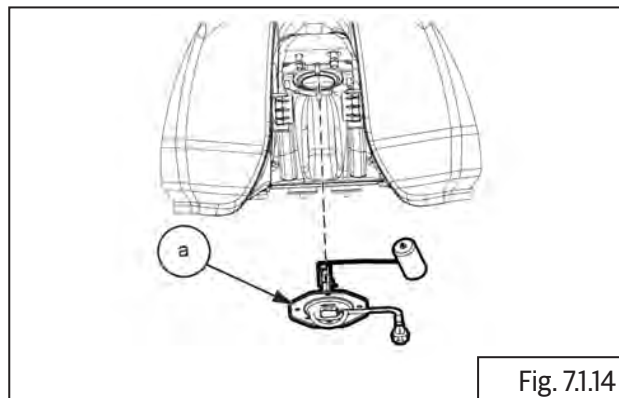

Fig. 7.1.14

- Remove float assembly **(a)** from fuel pump **(b)**.

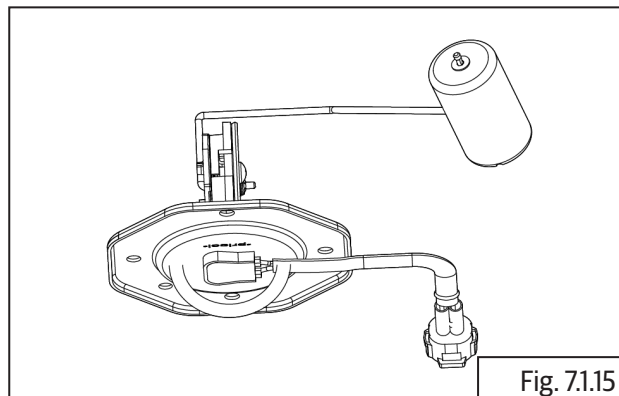

Fig. 7.1.15

⚠ CAUTION

Make sure the dust in the stainer does not enter the fuel pump.

Inspection

7.1.9. Fuel Float

- Check resistance at float unit pins at lower position.
- Check the resistance at float unit pins at higher position.
- Inspect float assembly for fuel ingress. Replace if fuel float assembly is punctured.

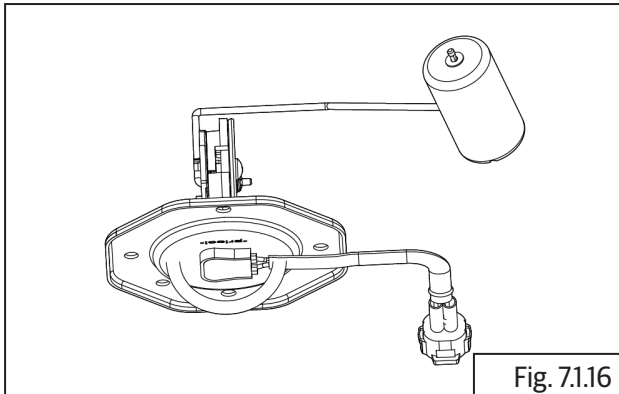

7.1.10. Fuel Pump

- Check resistances at fuel pump **(a)** terminals **(b)**. Replace if resistances are out of specifications.

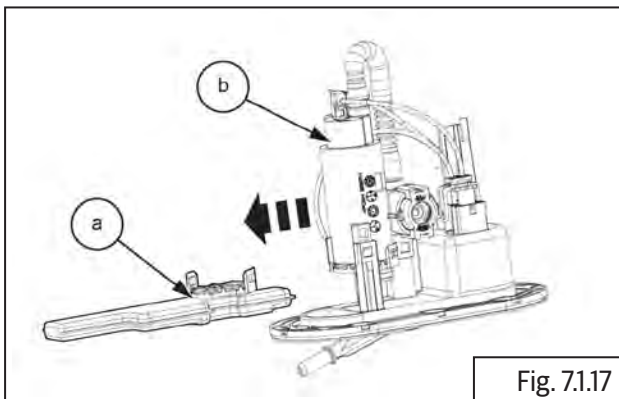

7.1.11. Fuel Filter

- Replace fuel filter for every 30,000 Kms.

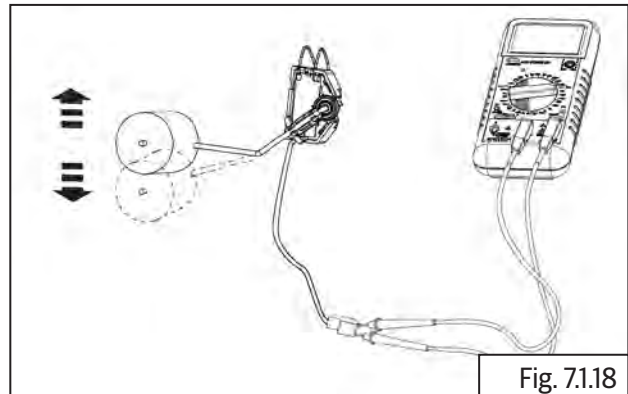

- Replace following whenever fuel system is dismantled:
 - O-rings and gaskets
 - Rubber hoses
 - Fuel filters

Assembly

7.1.12 Fuel Float

- Gently lock the fuel float **(a)**.

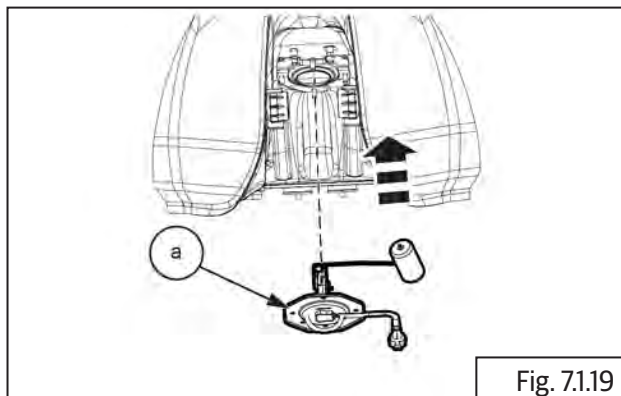

- Install 4 Nos. nut **(a)** on the float assembly.

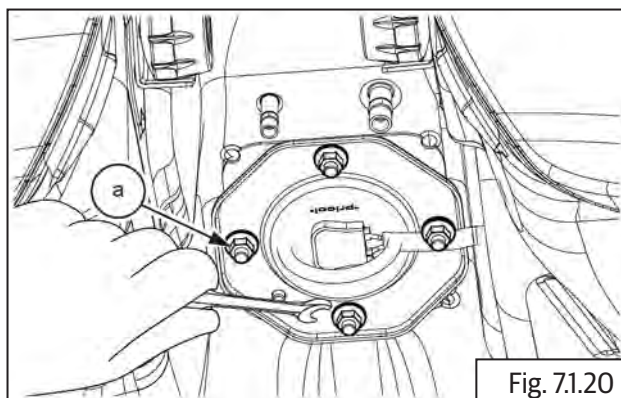

⚠ CAUTION

Ensure assembly of new seal every time after dismantling, to prevent leakage.

7.1.13. Fuel Level Sensor

- Align the slot **(a)** with frame key provided in the cover **(b)**.

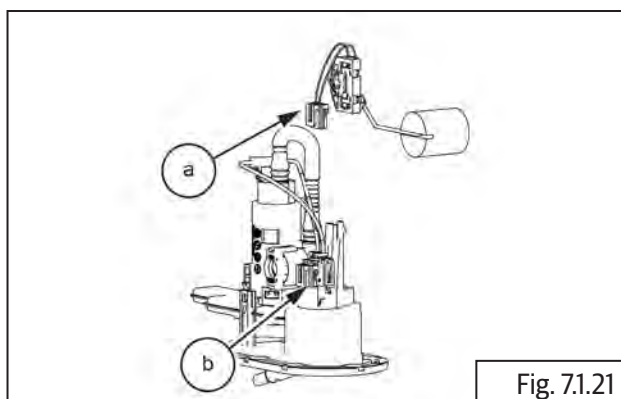

- Gently insert the Fuel level sensor **(a)** in the downwards direction till you hear a click sound.

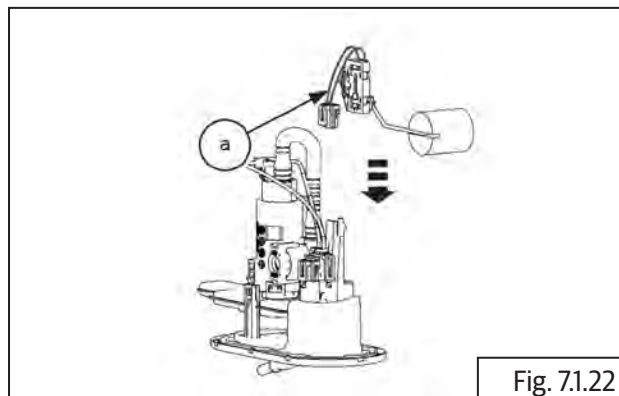

⚠ CAUTION

Ensure assembly of new seal every time after dismantling, to prevent leakage.

7.1.14. Fuel Pump

- Locate O-rings **(a)** and **(b)** on fuel pump. Ensure it is seated properly on the pump **(c)**.

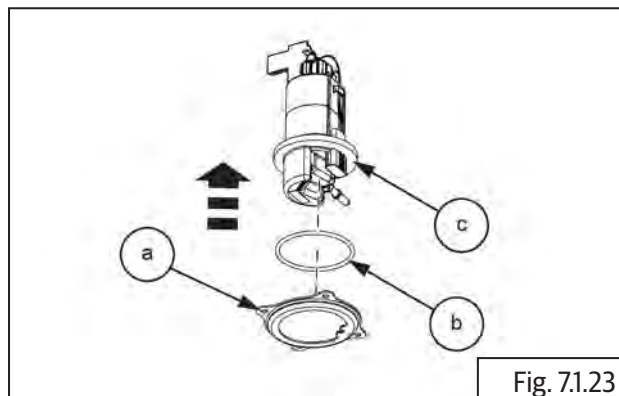

- Assemble fuel pump **(a)** into tank with outlet pipes facing towards rear of the tank.

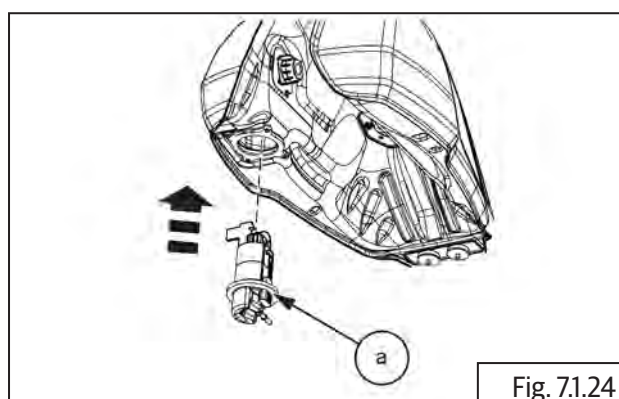

- Locate and tighten 4 Nos. Hex socket head bolts **(M5) (a)** to assemble fuel pump on fuel tank.

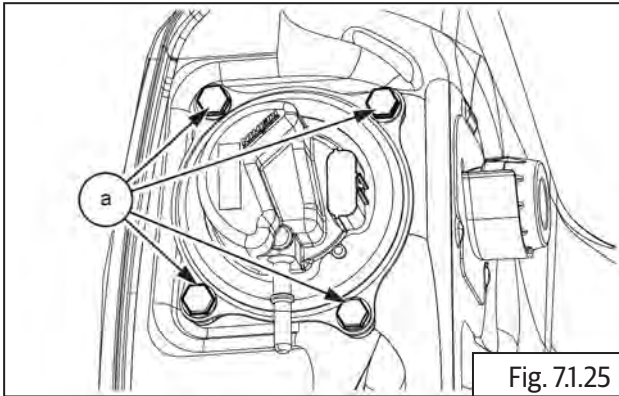

Fig. 7.1.25

	10 mm Socket with Ratchet
Torque	10-12 N-m/1.0-1.2 kgf-m

7.1.15. Fuel Tank

- Hold and slide fuel tank **(a)** into frame guide **(b)** and ensure bush in fuel tank are aligned into guide in frame.

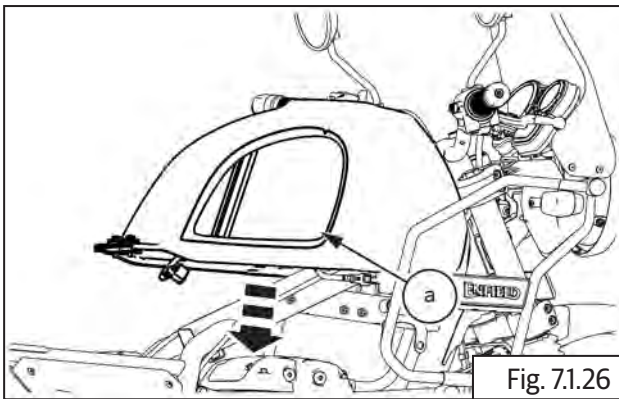

Fig. 7.1.26

7.1.16. Drain Hose

- Gently lift fuel tank and connect drain hose connection **(a)** to fuel tank **(b)**.

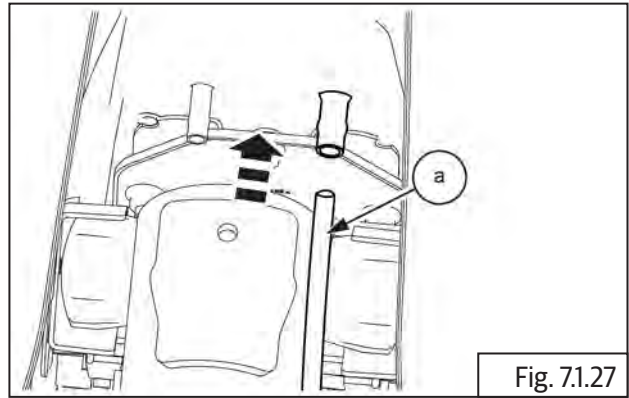

Fig. 7.1.27

7.1.17. EVAP Connections to Fuel Tank

- Connect EVAP connection hose **(a)** to fuel tank **(b)**.

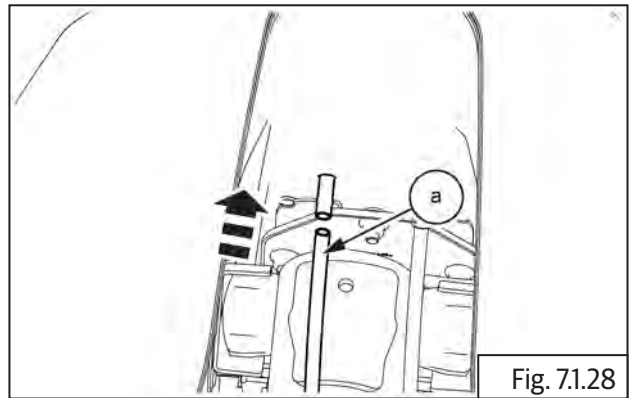

Fig. 7.1.28

7.1.18. Fuel Hose (Fuel Pump to Injector)

- Connect fuel hose **(a)** into quick fix connector **(b)** and ensure lock button is locked with a tick sound.

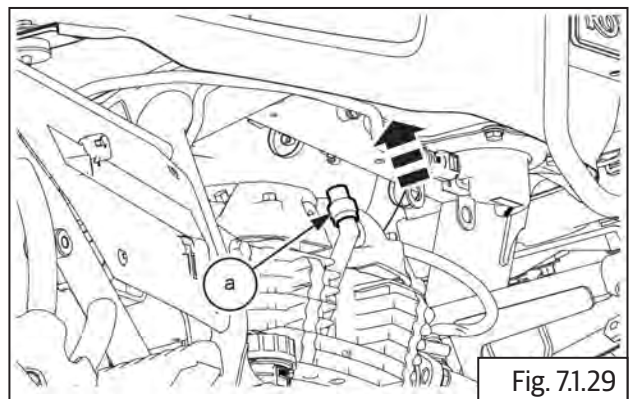

Fig. 7.1.29

7.1.19. Fuel Pump Connector

- Connect fuel pump connector **(a)** into fuel pump **(b)**.

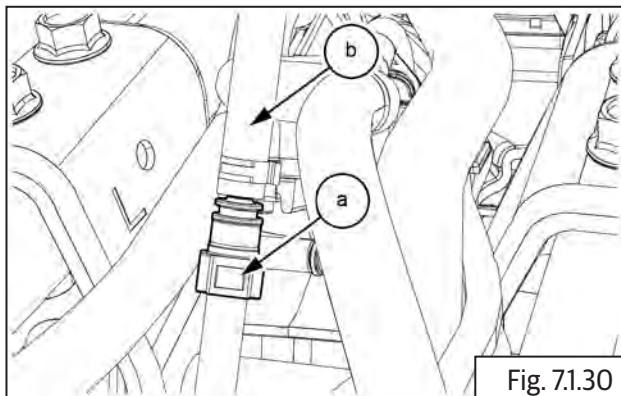

Fig. 7.1.30

- Gently lower the fuel tank into frame.
- Locate and tighten 2 No. Hex head bolts **(M5) (a)** on rear end of fuel tank **(b)**.

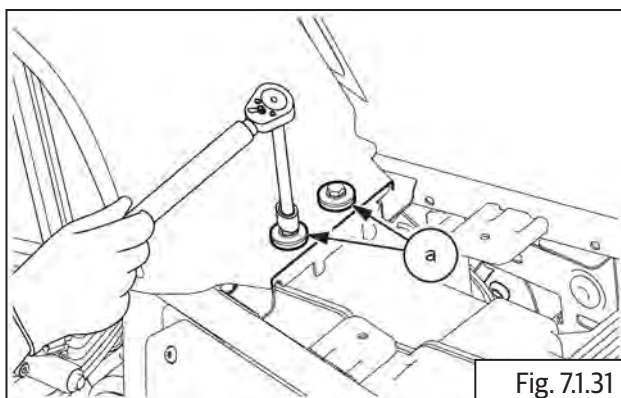



Fig. 7.1.31

	10 mm Socket with Ratchet
Torque	10-12 N-m/1.0-1.2 kgf-m

NOTE

- *Switch ON and OFF the ignition twice and visually check for any fuel leakage or wet on the tank and components, If anything found, inspect and rectify the issue.*

**EVAPORATIVE (EVAP) EMISSION CONTROL
SYSTEM**

CONTENTS	PAGE
8. Evaporative (EVAP) Emission Control System	298
8.1. Evaporative (EVAP) Emission Control System	298
Dismantling.....	298
8.1.1. Canister	298
8.1.2. EVAP Purge Valve	300
Inspection	301
8.1.3. Charcoal Canister	301
8.1.4. Purge Valve	301
8.1.5. Hoses	301
8.1.6. Hose Connectors	302
8.1.7. EVAP System Leak Test Procedure.....	302
8.1.8. EVAP Service hose	302
Assembly	302
8.1.9. EVAP Purge Valve	302
8.1.10. Canister	303

8. Evaporative (EVAP) Emission Control System

⚠ WARNING

Before dismantling any part of the EVAP system, ensure the engine and exhaust systems are at ambient temperature. Evaporative fuel vapors are highly inflammable and explosive, which can result in serious injury and or fatal accidents.

⚠ WARNING

DO NOT damage or puncture any part of the EVAP system like canister, purge valve etc. DO NOT blow high compressed air into the canister or purge valve as it can result in an explosion.

⚠ CAUTION

Ensure the motorcycle is upright on a firm and flat surface.

- Ensure ignition key and engine stop switch are in OFF position.
- Disconnect battery negative (-) terminal ([section 11.5.1](#)).
- Before removing any part of the EVAP system, open fuel tank cap ([section 7.1.4](#)) to release the pressure inside.

8.1. Evaporative (EVAP) Emission Control System

Dismantling

8.1.1. Canister

For EURO IV Models

- Loosen 2 hex. bolts **(a)** mounted on skid plate on RH of the skid plate.

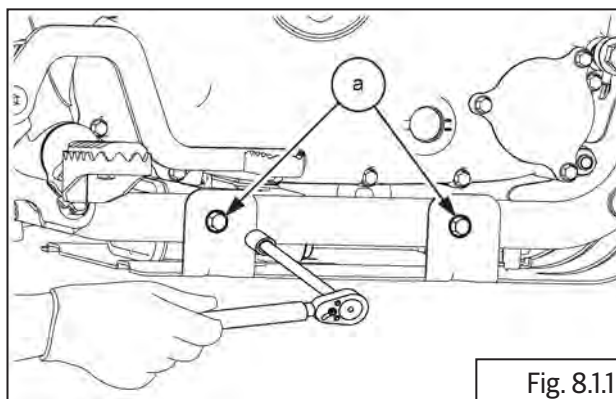

Fig. 8.1.1

- Loosen 2 hex. bolts **(a)** mounted on skid plate on LH of the skid plate..

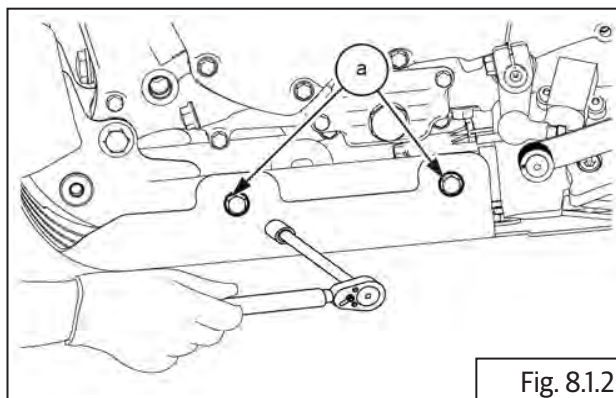

Fig. 8.1.2



5 mm Socket with Ratchet

- Gently remove the canister bracket assy along with rubber strap

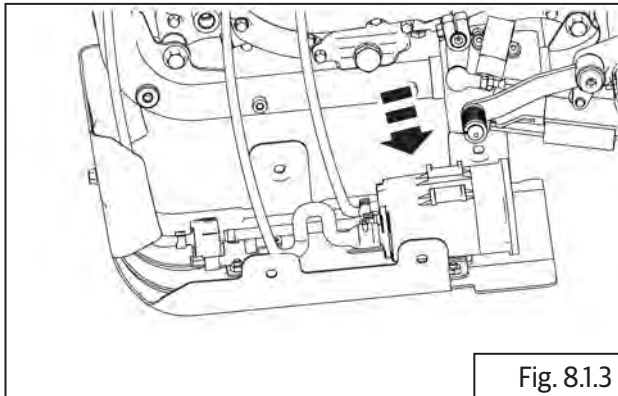

Fig. 8.1.3

⚠ CAUTION

Do not apply excessive force to pull out canister with hoses as it will damage the canister and the hose pipes.

- Disconnect inlet (a) hose from canister.

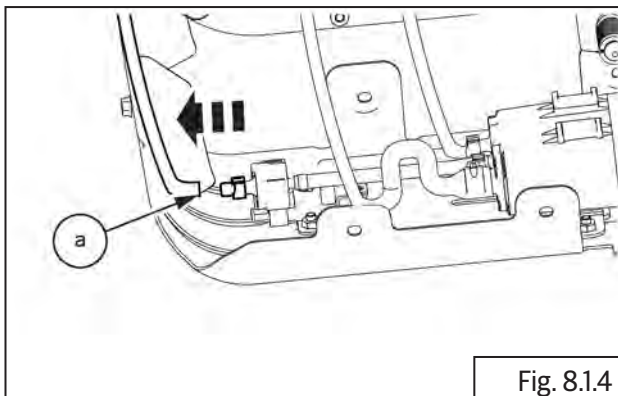

Fig. 8.1.4

- Disconnect outlet (a) hose from canister.

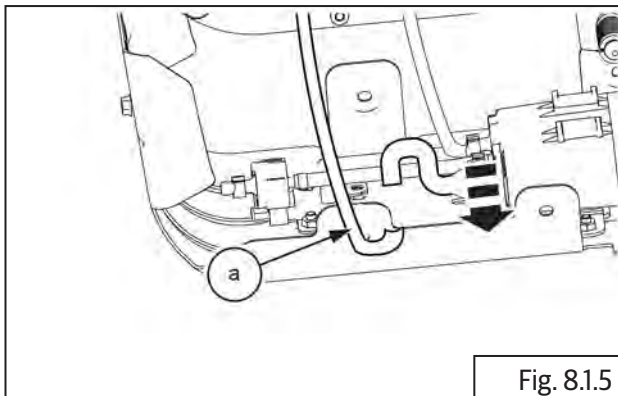

Fig. 8.1.5

- Disconnect drain (a) hose from canister.

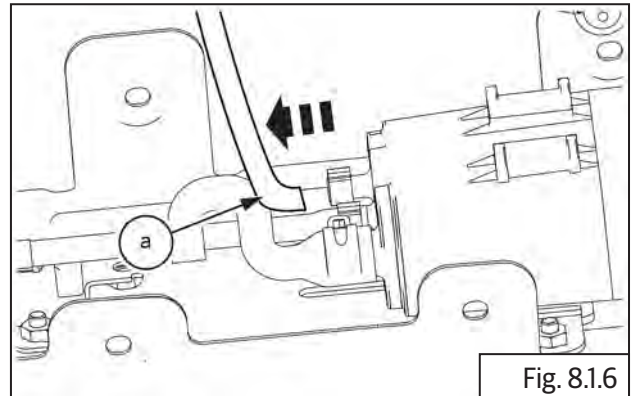

Fig. 8.1.6

- Gently remove the canister and the skid plate assy.

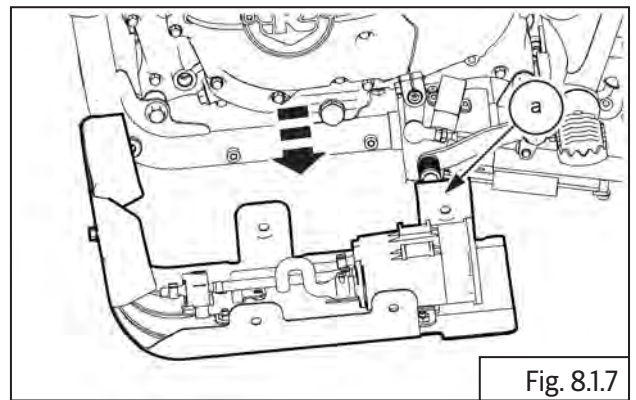

Fig. 8.1.7

- Loosen 2 hex. bolts (a) mounting the canister from the skid plate assy.

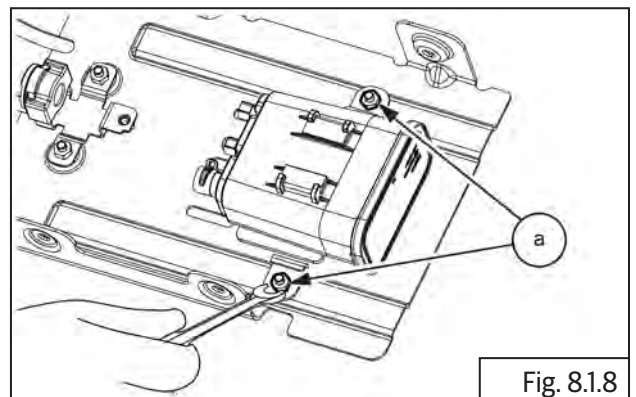

Fig. 8.1.8

- Gently remove the canister **(a)** from the skid plate.

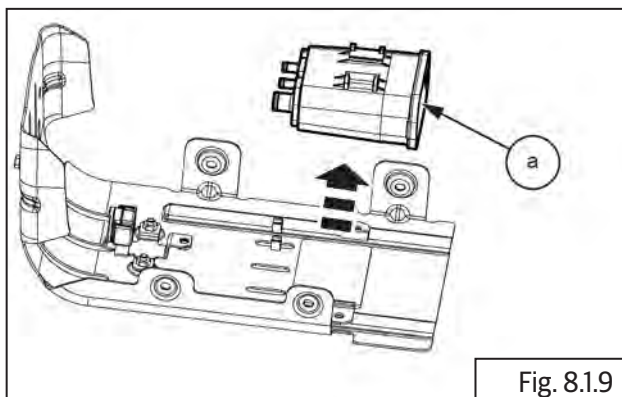

Fig. 8.1.9

- Remove the canister **(a)** by removing the 1 No. Hex bolt.

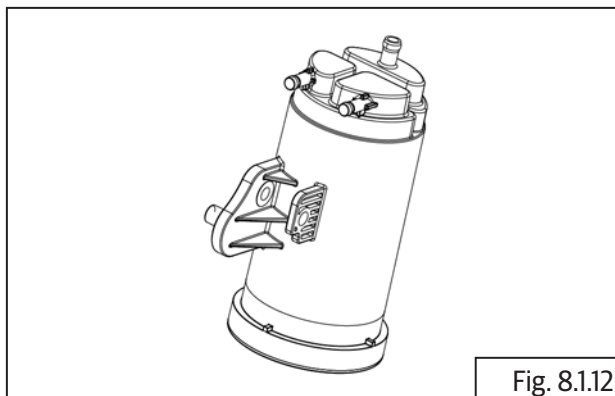

Fig. 8.1.12

For EURO V Models

- Remove the following parts
 - Rider seat.
 - Rear mud guard.
- Disconnect the inlet hose, outlet hose **(a)** and drain hose from the canister.

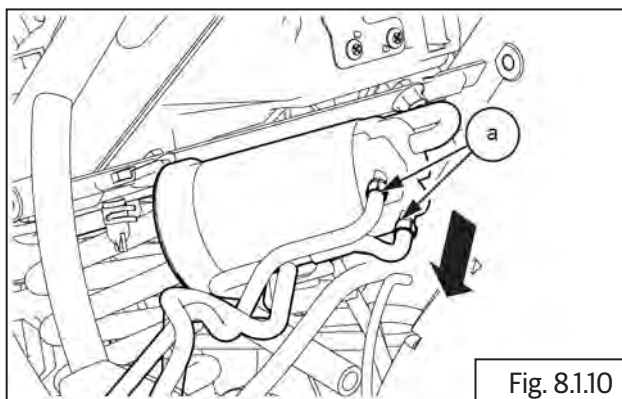

Fig. 8.1.10

8.1.2. EVAP Purge Valve

- Remove the following parts:
 - Rider seat
 - Fuel tank.
- Release purge valve **(a)** from the frame **(b)** by pushing backwards.

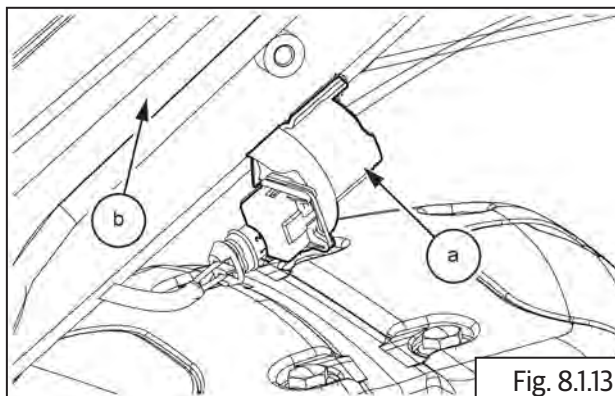

Fig. 8.1.13

- Loosen and remove the hex bolt (a) from the canister.

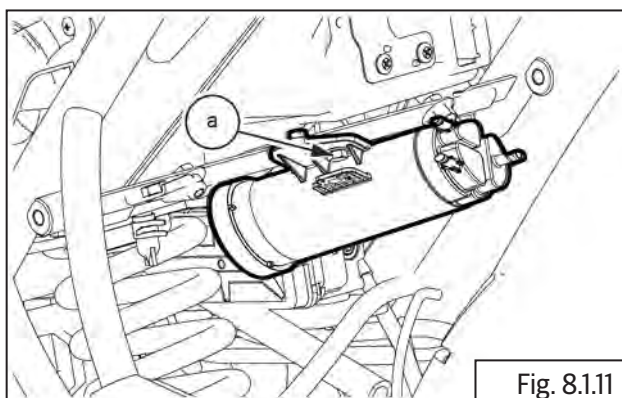

Fig. 8.1.11

- Disconnect hose **(a)** from canister and purge valve.

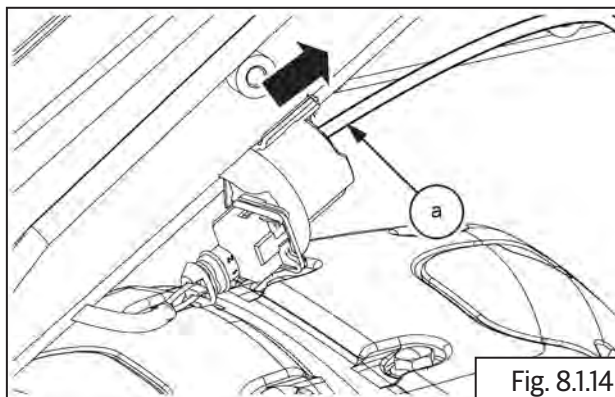
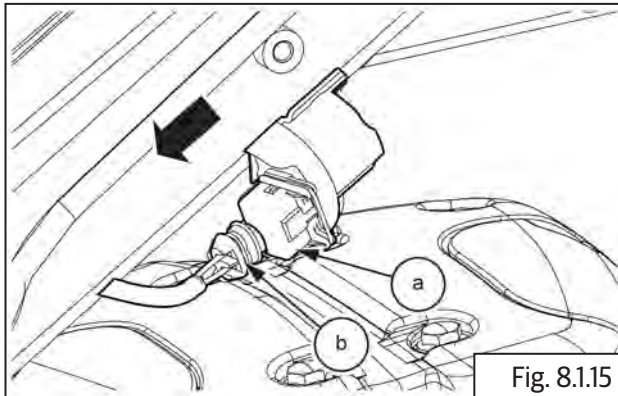
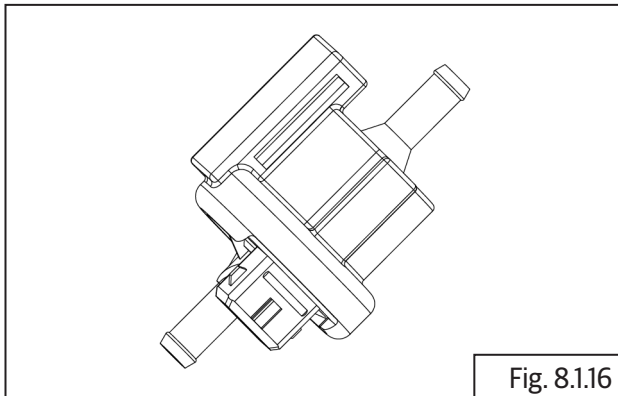

Fig. 8.1.14

- Disconnect electrical connector **(b)** from purge valve **(a)**.



- Remove purge valve and store carefully.



Inspection

8.1.3. Charcoal Canister

- Inspect rubber hoses and joints periodically for any cuts cracks or fractures. Replace if damaged.
- Inspect Canister periodically for any damage to its body cuts or cracks.
- Replace all rubber hoses and connectors every 40,000 Kms or 25,000 Miles.
- Clean and inspect for any damage or crack on canister. Replace if necessary.
- Gently shake canister to feel if there is wet fuel inside. If suspected replace canister (weight 385 ± 5 gms).
- Blow very low pressure air (5 psi) through the inlet port and check for the free flow of outlet side. If restricted or no air, replace the canister.

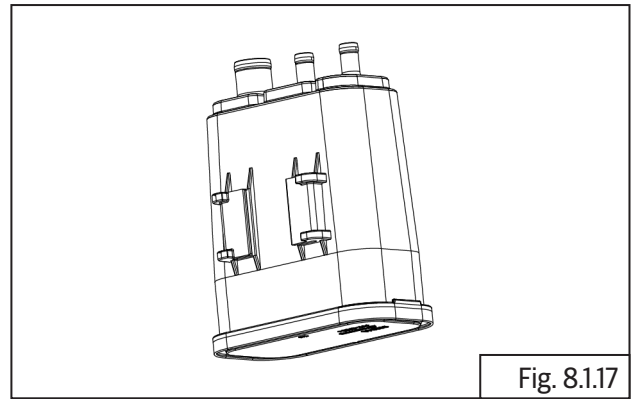

8.1.4. Purge Valve

- Clean and visually inspect the EVAP purge valve for any damage or crack.
- Check purge valve in EMS section, replace if found defective.
- Blow low pressure air (5 psi) through hose connecting to throttle body and check for pressure release through hose connecting to canister. If air releases, purge valve is defective and replace.

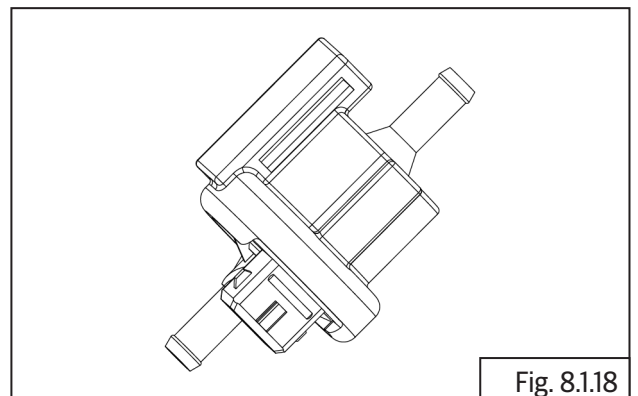

8.1.5. Hoses

- Check hose for any crack, pinch, wear out or hardening. Replace if defective.
- Replace hoses as mentioned in periodic maintenance schedule.

8.1.6. Hose Connectors

- Check for any damages or cracks and replace if defective.

Do's & Don'ts

- Do not fill fuel tank above anti-splash plate inside fuel tank as it will cause fuel to get into EVAP system.

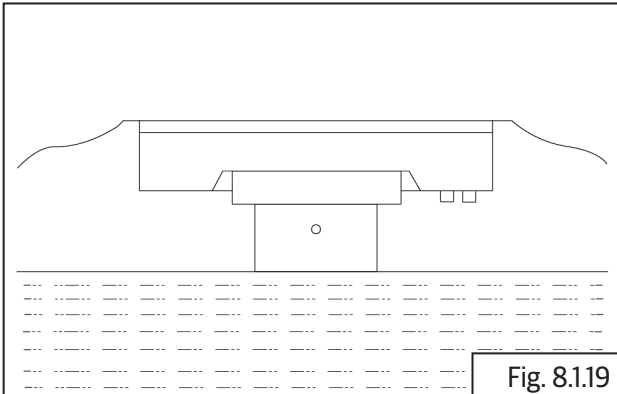

- Do not use motorcycle if any part of EVAP system is damaged.
- Do check the EVAP system periodically for damages and leakages.

8.1.7. EVAP System Leak Test Procedure

- Ensure the systems hoses are connected correctly.
- Block the EVAP atmosphere breather.
- Block the LH side throttle body Hose, Purge.
- Connect a hose to the fuel tank to EVAP hose to allow a pressure to be applied.
- Connect another hose to the RH side throttle body Hose, Purge.
- Pressurise the system through both the Evap Canister atmosphere breather and the RH side throttle body Hose, Purge at the same time as below:
 1. Fill at 20kPa for 20 Seconds.
 2. Stabilize, 50 Seconds.
 3. Drop less than 300 Pa over 5 minutes.

8.1.8. EVAP Service hose

- Gently Pull the Plug from the service hose.
- Allow to drain the accumulated fuel (if any) during splashing.
- Install the plug in the service hose after draining the accumulated fuel completely.
- Ensure the plug is fully inserted. (To be followed in every service interval as per the Periodical Maintenance Schedule)

Assembly

8.1.9. EVAP Purge Valve

- Connect throttle body hose **(a)** to outlet near wiring coupler in purge valve.

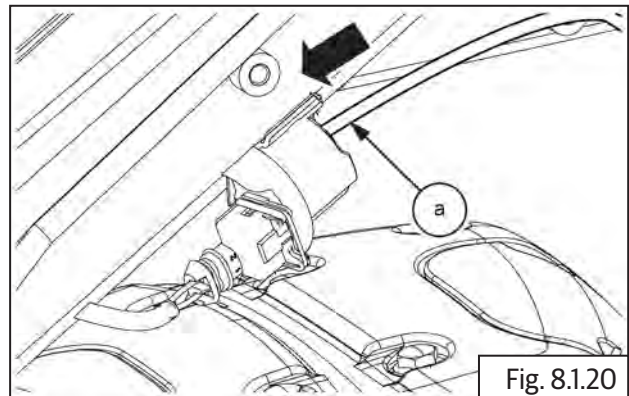

- Connect the electrical connector **(b)** to purge valve. **(a)**.

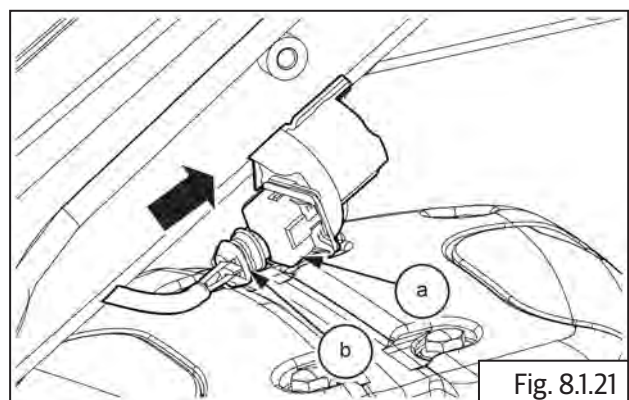

- Locate purge valve **(a)** in the frame **(b)**.

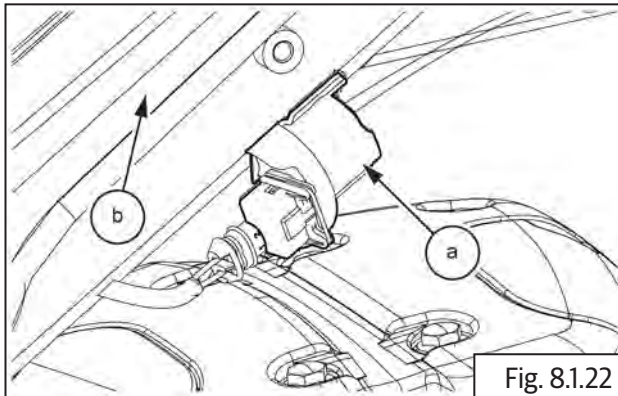

- Assemble the following parts:
 - Fuel tank (section 7.1.15).
 - Seat (section 6.7.7).

8.1.10. Canister

For EURO IV Model

- Locate canister **(a)** on bracket **(b)** in frame. Push it completely to lock in place.

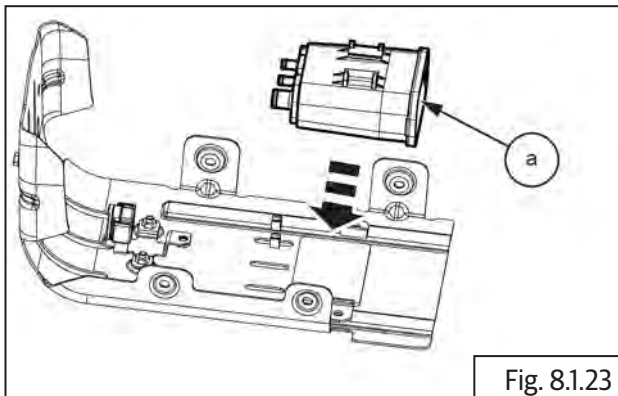

- Locate 2 Nos. bolt **(a)** on the canister mounting.

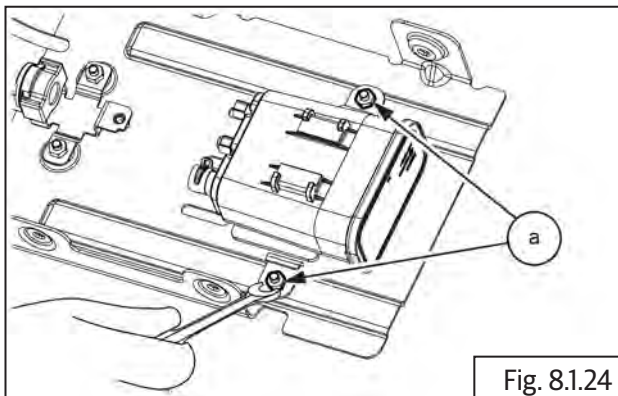

	10 mm Socket with Ratchet
Torque	10 N·m/1.0 kgf m

- Assemble the canister skid plate assy. **(a)**.

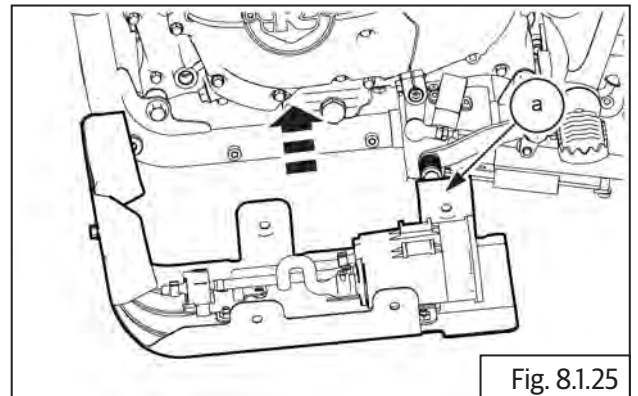

- Connect the drain hose **(a)** to the canister.

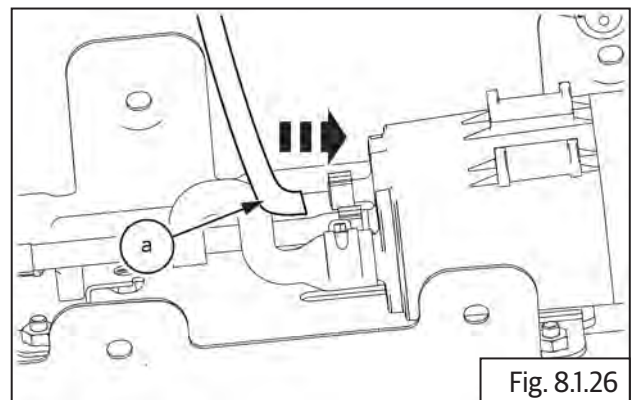

- Connect the outlet hose **(a)** to the canister.

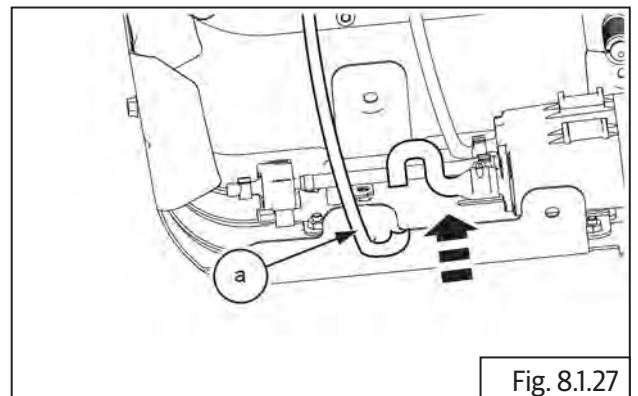

- Connect the inlet hose **(a)** to the canister.

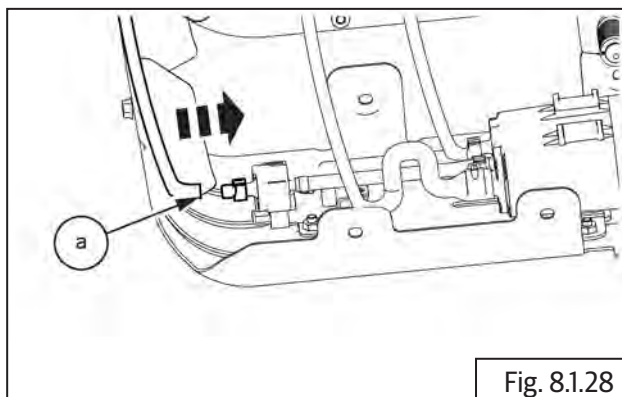

Fig. 8.1.28

- Locate and lock the skid plate assy. **(a)** to the frame.

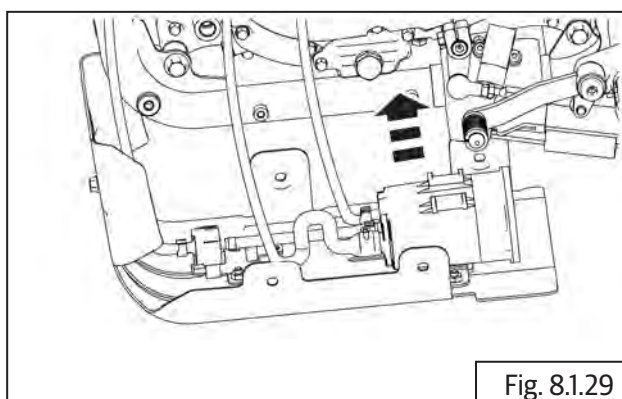

Fig. 8.1.29

- Install the 2 Nos. Hex. bolt **(a)** from the LH side.

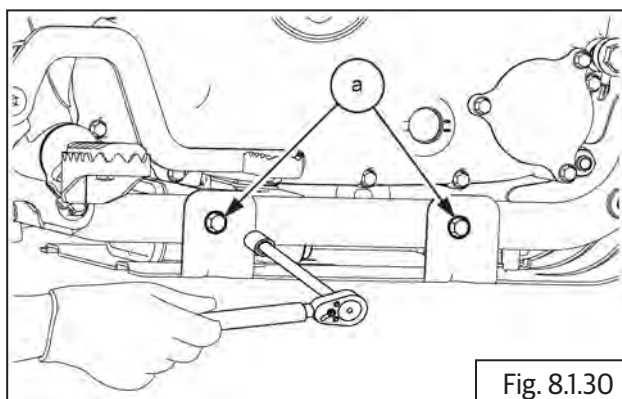

Fig. 8.1.30

- Install the 2 Nos. Hex. bolt **(a)** from the RH side.

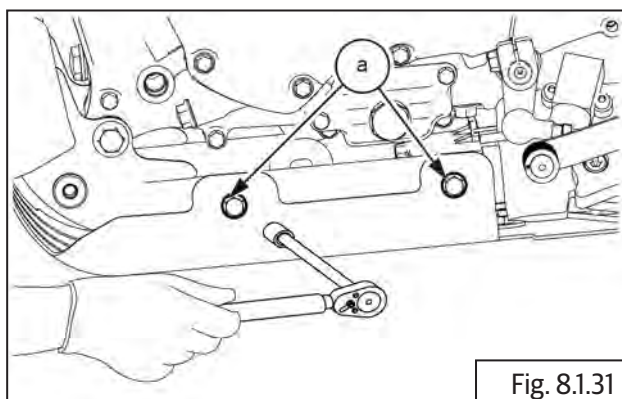

Fig. 8.1.31

For EURO V Model

- Install the canister on the bracket using the 1 No. Hex bolt **(a)**.

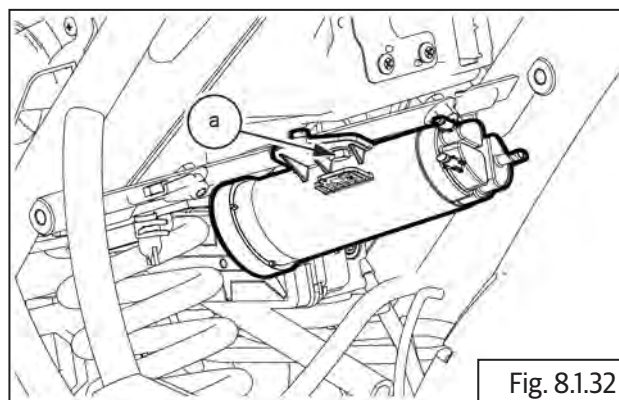

Fig. 8.1.32

- Connect the drain hose, outlet hose and inlet hose **(a)** to the canister.

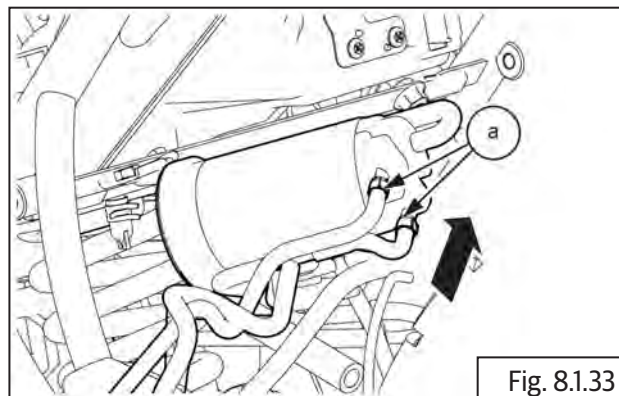

Fig. 8.1.33

- Assemble the following parts:
 - Rear Mudguard ([section 11.5](#)).
 - Seat ([section 7.1.15](#)).

BRAKES AND ABS

Brakes and ABS

CONTENTS	PAGE
9. Brakes and ABS	308
Dismantling	308
9.1. Brake - Front	308
9.1.1. Master Cylinder Assembly - Front.....	308
9.1.2. Brake Caliper - Front	310
9.1.3. Brake Disc - Front.....	311
9.2. Brake - Rear	312
9.2.1. Master Cylinder Assembly - Rear	312
9.2.2. Brake Caliper Assembly - Rear	315
9.2.3. Brake Disc - Rear	316
Inspection	316
Assembly	320
Brake - Rear	320
9.2.4. Brake Disc - Rear	320
9.2.5. Brake Caliper Assembly - Rear	320
9.2.6. Master Cylinder Assembly - Rear	322
Rear Brake pedal	324
Brake - Front	325
9.2.7. Brake Disc - Front	325
9.2.8. Brake Caliper - Front	325
9.2.9. Master cylinder - Front.....	327
9.3 Anti-lock Braking System (ABS)	330
Working Principle	330
Typical Motorcycle Braking Distance	330
Functions and Specifications of the ABS Aggregates	331
Dismantling	336
9.3.1. Modulator	336
9.3.2. Wheel Speed Sensor - Front.....	337

CONTENTS	PAGE
9.3.3. Wheel Speed Sensor - Rear	338
9.3.4. Toner Ring - Front	338
9.3.5. Toner Ring -Rear	338
Assembly	339
9.3.6. Toner Ring - Front	339
9.3.7. Toner Ring -Rear	339
9.3.8. Wheel Speed Sensor - Rear	339
9.3.9. Wheel Speed Sensor - Front.....	339
9.3.10. Modulator	340
9.3.11.....	ABS
DTC Codes	344
9.4. Preparation (Front Disc Brake)	347
9.5. Reassembly.....	349
9.6. Preparation (Rear Disc Brake).....	350
9.7. Reassembly	351
9.8. Brake Bleeding	353
9.8.1. Front Brake Bleeding	353
9.8.2. Front Brake Fluid Leakage	356
9.8.3. Front Brake Fluid Top up.....	357
9.8.4. Rear Brake Bleeding.....	358
9.8.5. Rear Brake Fluid Leakage.....	360
9.8.6. Rear Brake Fluid Top Up.....	361

9. Brakes and ABS

Dismantling

9.1. Brake - Front

⚠ CAUTION

Ensure the motorcycle is upright on a firm and flat surface.

Support motorcycle with suitable equipment below swing arm frame.

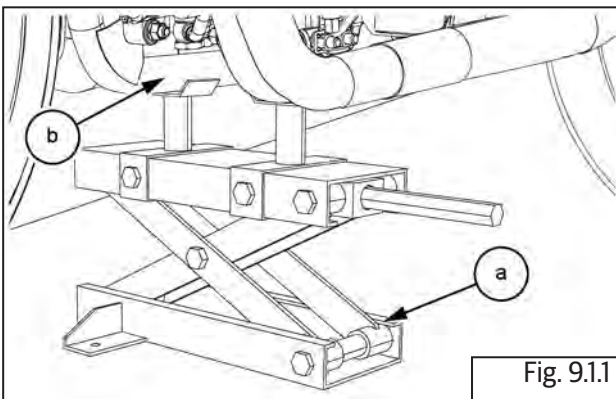

Fig. 9.1.1

- Before dismantling brake assembly, bleed out brake fluid ([section 9.8.1](#)).

NOTE

- If brake pads are being replaced, then it is not necessary to perform system bleeding.
- Wheel should be dismantled only for brake disc plate removal.

⚠ CAUTION

Whenever front brake caliper assembly is dismantled from front wheel, **DO NOT** press brake lever as the piston in the caliper will move out/get misaligned.

DO NOT remove or disturb the wheel speed sensor on fork end LH.

9.1.1. Master Cylinder Assembly - Front

- Remove the following part:
- Rear view mirror from handlebar RH ([section 6.3.1](#)).

⚠ CAUTION

Ensure master cylinder assembly is supported carefully while disconnecting.

- Disconnect brake lamp switch connectors (a) from brake lamp switch (b).

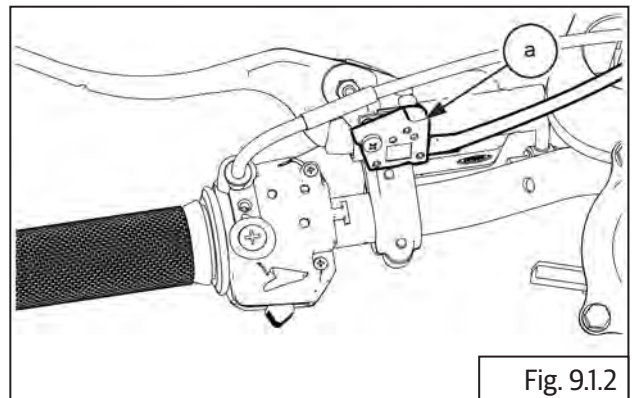

Fig. 9.1.2

- Loosen and remove banjo bolt (a) holding the brake hose (b) to front master cylinder to ABS modulator (c).

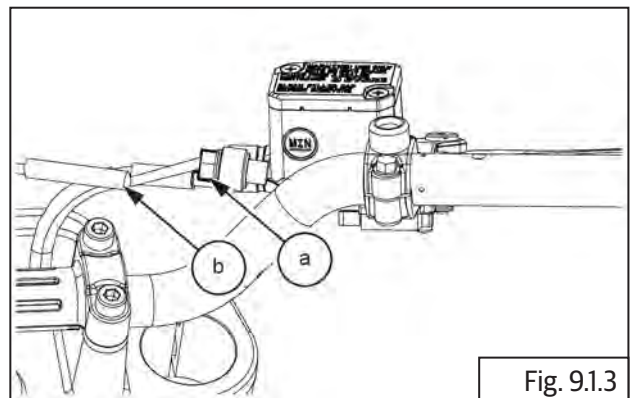
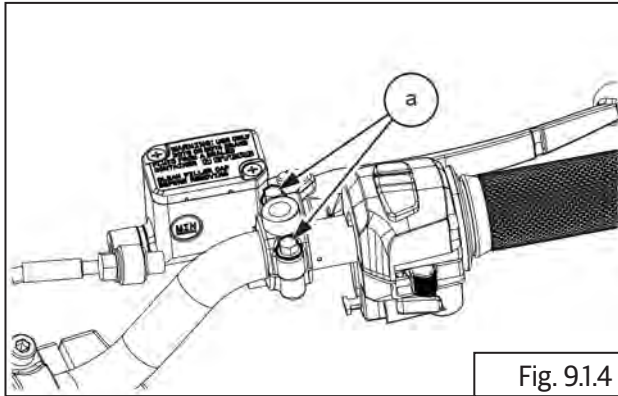

Fig. 9.1.3



12 mm Socket with Ratchet

- Loosen and remove 2 Nos. Hex bolts **(M5) (a)** along with washers from clamp and remove master cylinder assembly from handlebar RH.



- Hold screw **(a)** at the top of brake lever, loosen and remove hex nut **(M6) (b)** at the bottom.
- Unscrew and remove top screw holding brake lever to master cylinder and remove brake lever.

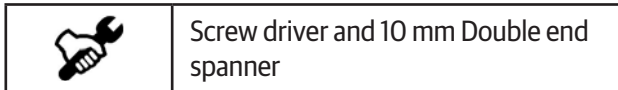
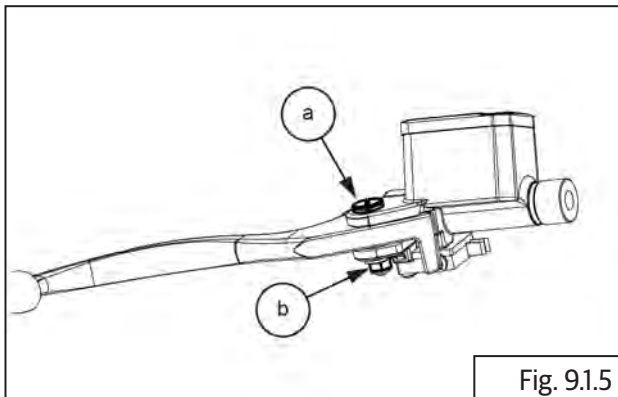

Dismantling Master Cylinder Front

- Remove boot **(a)** from the master cylinder assembly **(b)**.

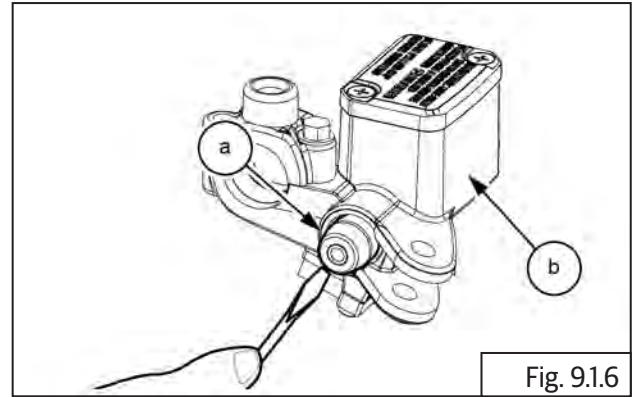

- Remove circlip **(a)** from the master cylinder assembly **(b)**.

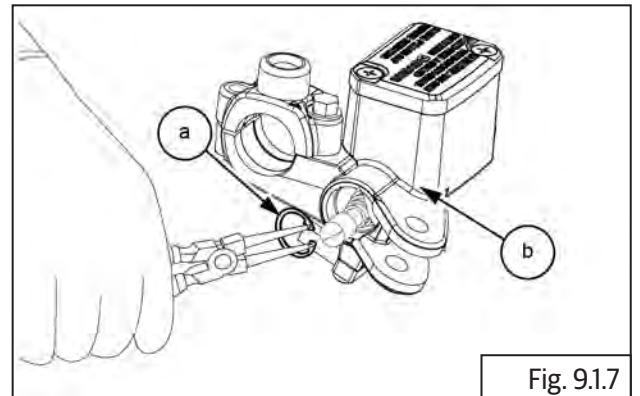

- Remove the conical spring (piston compression spring) **(a)** from piston **(b)**.

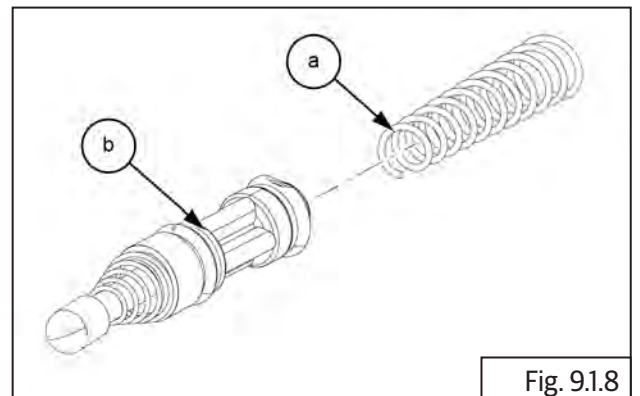

9.1.2. Brake Caliper - Front

- Gently remove hose from caliper assembly ([section 9.3.1](#)).
- Support the front brake caliper assembly suitably.
- Loosen and remove upper and lower Hex flange head bolts (**M10**) to remove front brake caliper assembly (**a**) from LH fork.

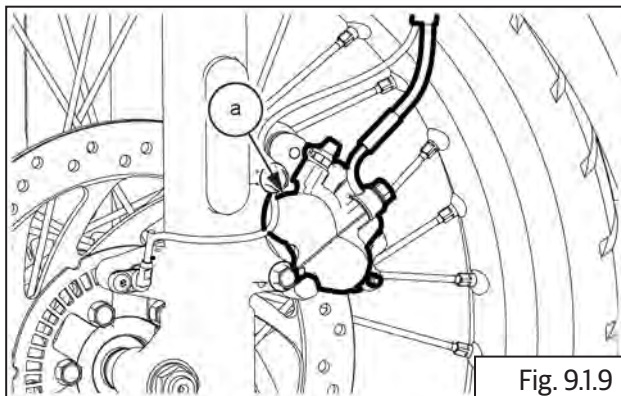

13 mm Socket with Ratchet

- Gently slide out front brake caliper assembly from front RH fork.
- Remove brake pad lock clip (**a**) from brake caliper assembly.

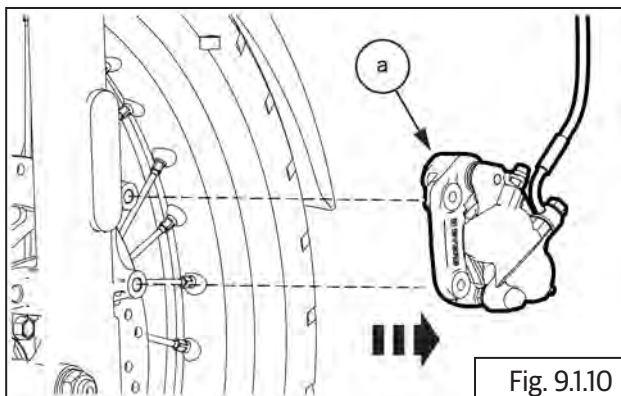

Nose plier

- Suitably support caliper and correctly tap brake pad pin (**a**) from inner side to outside.

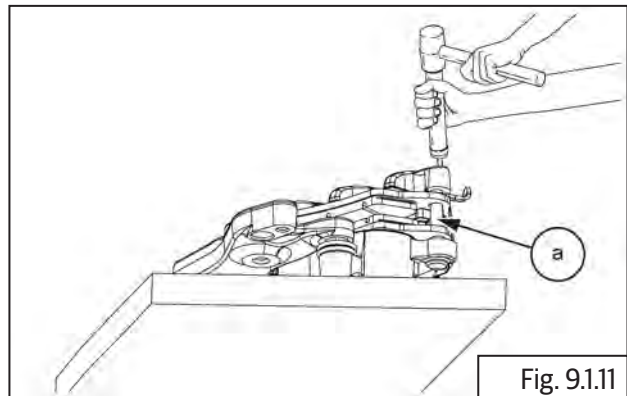

- Once pin (**a**) is free, gently pull out pin from brake caliper.

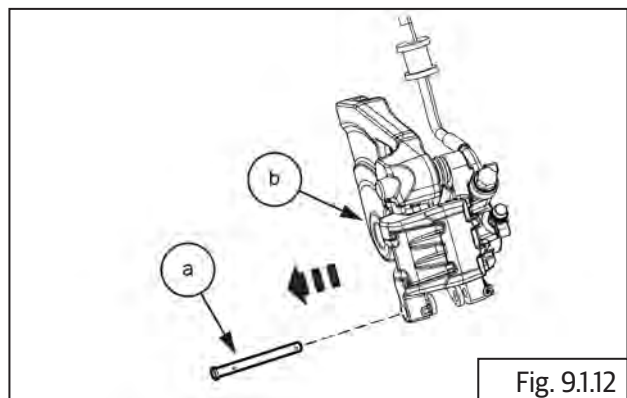

- Slide out and remove brake pads (**a**) from brake caliper front (**b**).

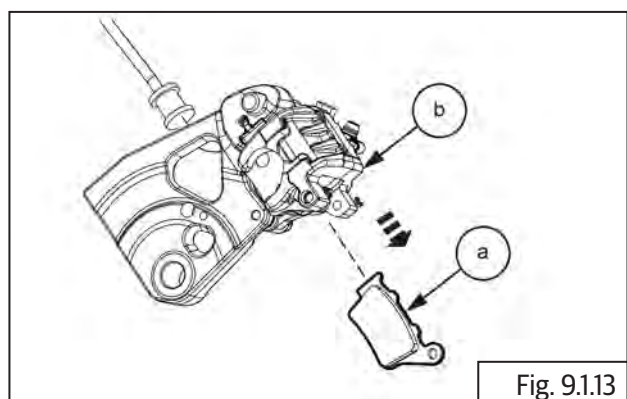

Dismantling Front Brake Caliper

- Remove the pad tensioner spring plate **(a)**.

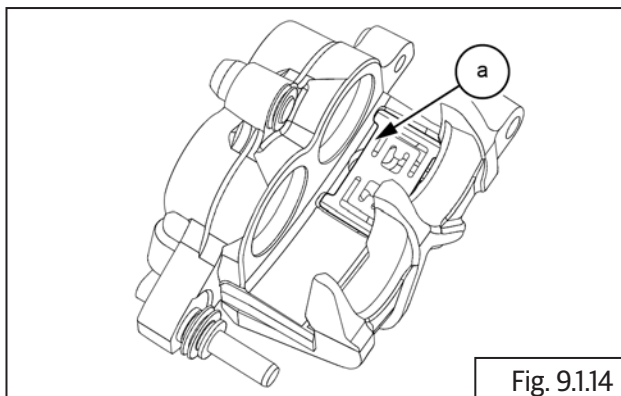

- Remove mounting bracket from caliper assembly.

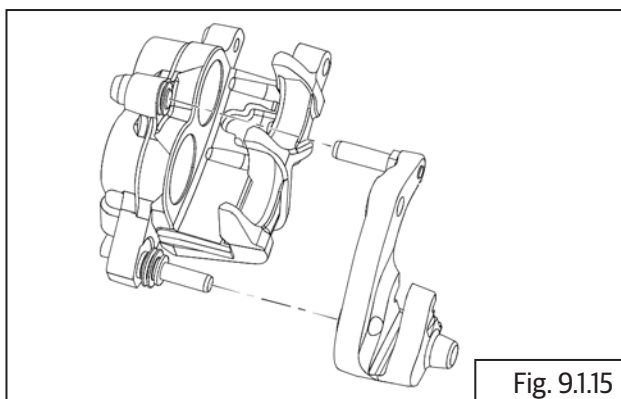

- Position caliper body with the pistons down and apply small squirts of air pressure to fluid inlet hole to remove pistons.

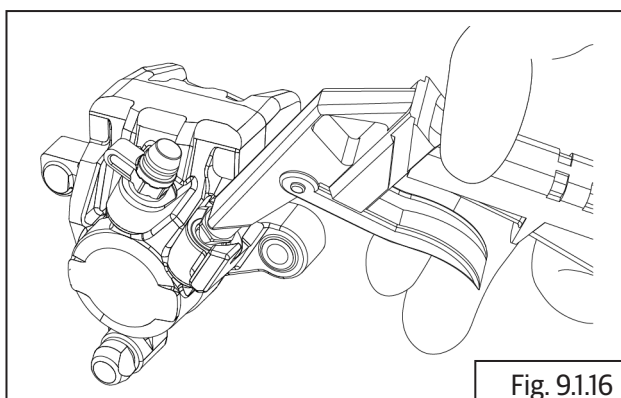

⚠ CAUTION

Do not use high pressure air or bring the nozzle too close to the inlet. Place a shop towel over the pistons to prevent the pistons from becoming projectiles. Push the dust seals and piston seals in and lift them out using a blunt tool. Care should be taken to avoid any damages on the bore of the sliding surface.

Enough care should be taken to avoid damages of the piston OD while servicing/handling. Remove the bleed screw.

9.1.3. Brake Disc - Front

- Remove front wheel ([section 6.8.1](#)).
- Ensure wheel assembly is placed on a flat surface with disc plate facing upwards.

⚠ CAUTION

Ensure wheel hub does not get damaged.

- Loosen and remove 5 Nos. Hex socket head bolts **(M8) (a)** from wheel RH in criss cross pattern holding toner ring and brake disc to hub.

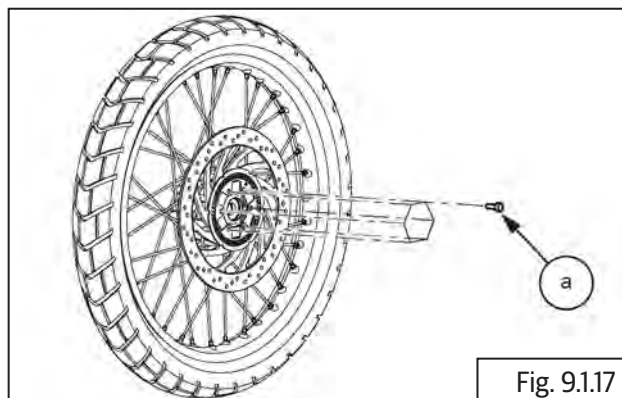

6 mm Allen socket with Ratchet

⚠ WARNING

DO NOT place/store the wheel with disc facing downward. It will cause bends and damages and change warpage.

- Remove toner wheel **(a)** and keep it aside safely.

⚠ CAUTION

Avoid any bends or damages to the toner wheel as it will have serious effects on ABS performance.

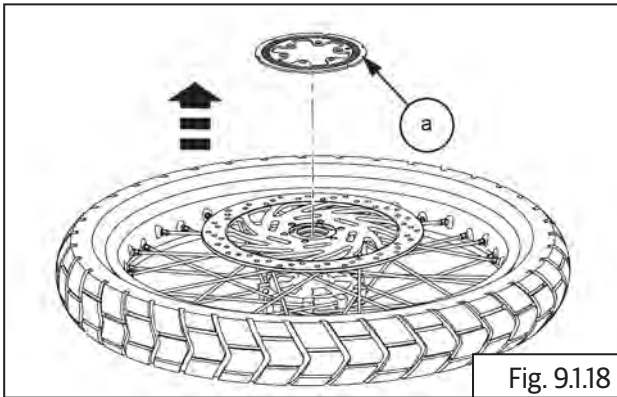

Fig. 9.1.18

- Remove front brake disc **(a)**.

⚠ CAUTION

Avoid any bends or damages to the brake disc as it will have serious effects on braking efficiency and will lead to juddering.

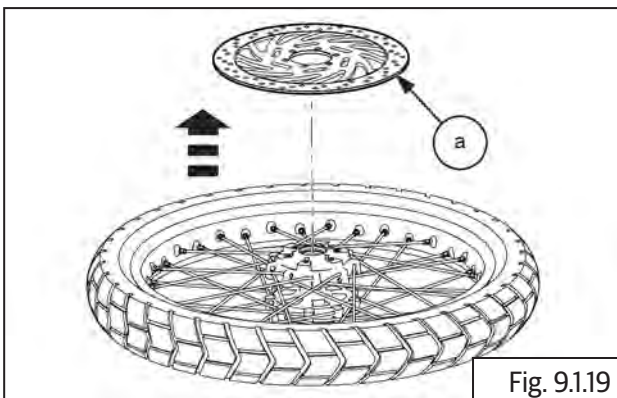

Fig. 9.1.19

9.2. Brake - Rear

⚠ CAUTION

Ensure the motorcycle is upright on a firm and flat surface.

Support motorcycle with suitable equipment below swing arm frame.

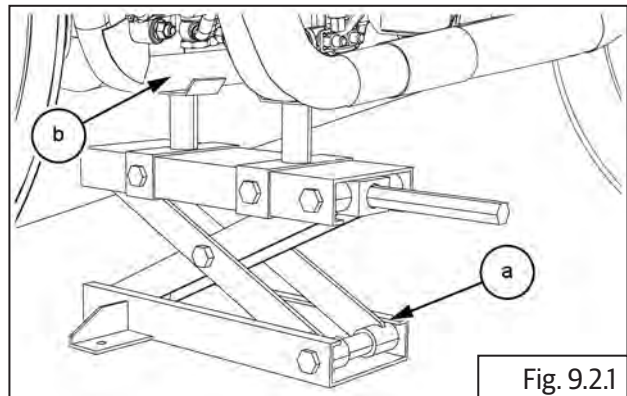

Fig. 9.2.1

9.2.1. Master Cylinder Assembly - Rear

- Remove split pin **(a)** from clevis pin located at the bottom of master cylinder assembly.

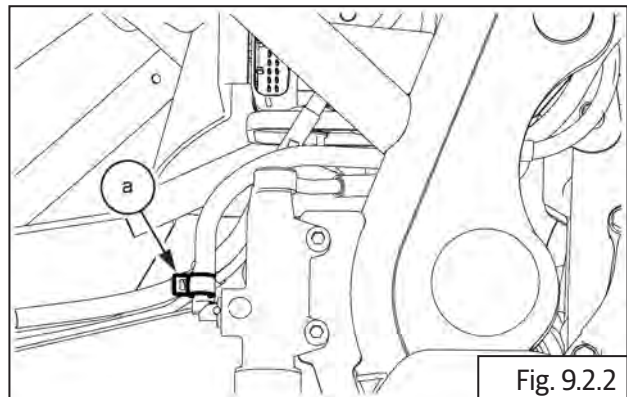

Fig. 9.2.2



Nose plier

- Remove reservoir hose from master cylinder.

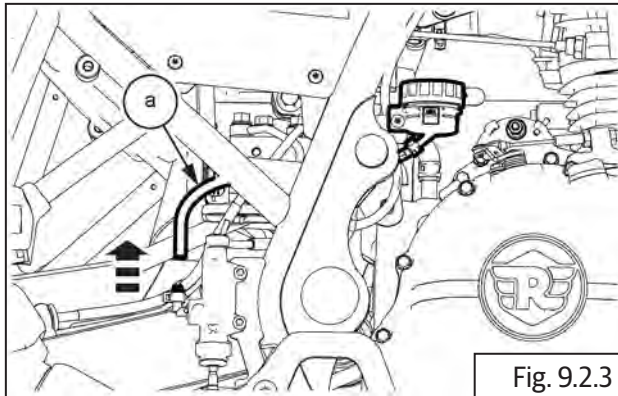

Fig. 9.2.3

- Collect brake fluid in container.

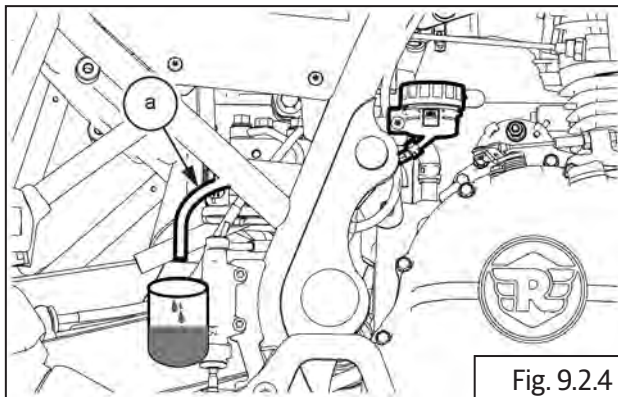

Fig. 9.2.4

- Loosen and remove 1 No. Allen bolts (a) to remove oil reservoir (b) from frame.

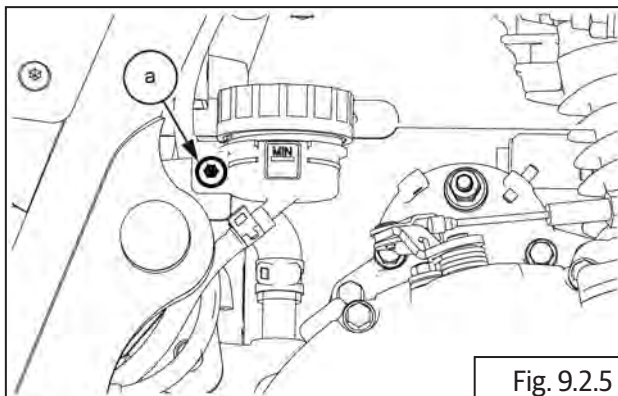

Fig. 9.2.5



4 mm Allen socket with Ratchet

- Loosen and remove 1 Nos. Hex socket head banjo bolt (a) along with copper washer (b) and brake hose (c).

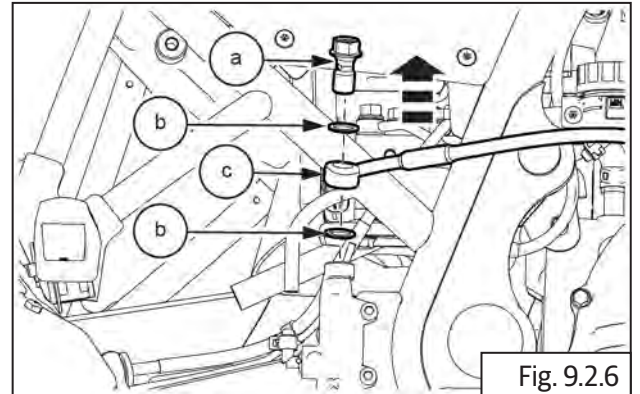

Fig. 9.2.6



12 mm Socket with Ratchet

- Loosen and remove 2 Nos. Hex socket head bolt (a) to remove master cylinder from frame.

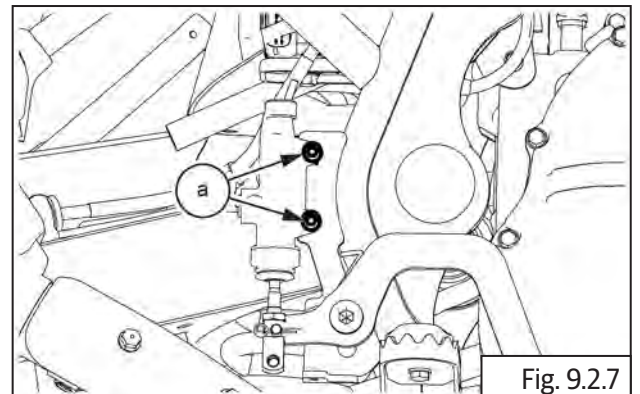

Fig. 9.2.7



10 mm Socket with Ratchet

Dismantling Rear Brake Master Cylinder

- Remove protective rubber boot from master cylinder.

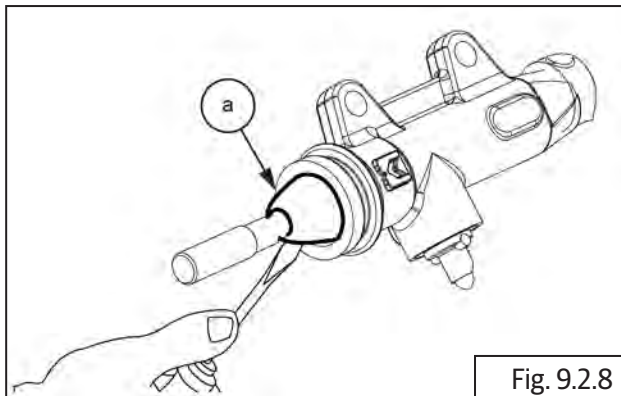

Screw driver

- Remove **(a)** circlip from the master cylinder body **(b)** slowly and carefully.

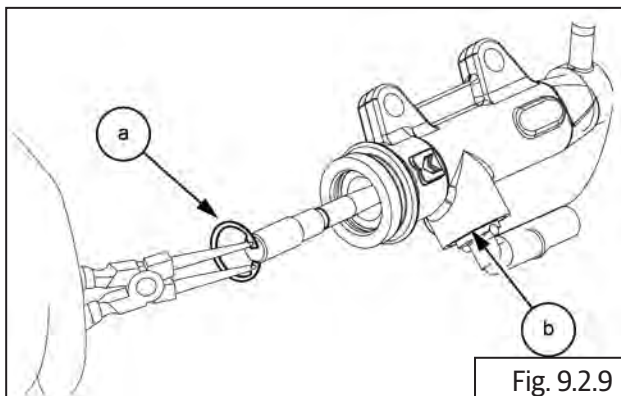

Circlip plier

- Gently pull out bush **(a)** with piston **(b)**, seals, spring guide and conical spring from master cylinder housing **(c)**.

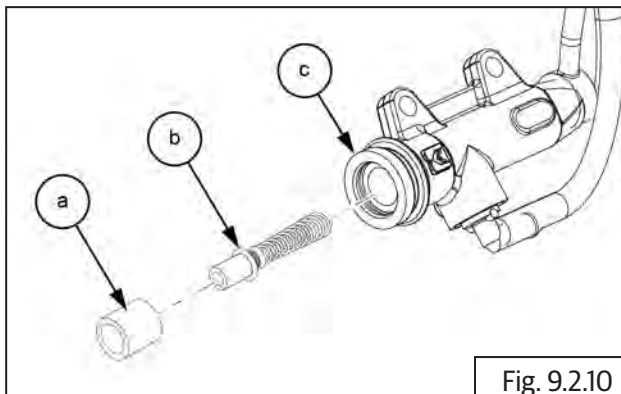

! CAUTION

Do not use any sharp tool to pull out the piston from the master cylinder. Pull out gently with minimum force.

Rear Brake Pedal

- Loose and remove 1 No. Allen bolt **(a)** (M10) along with brake pedal **(b)** from motorcycle.

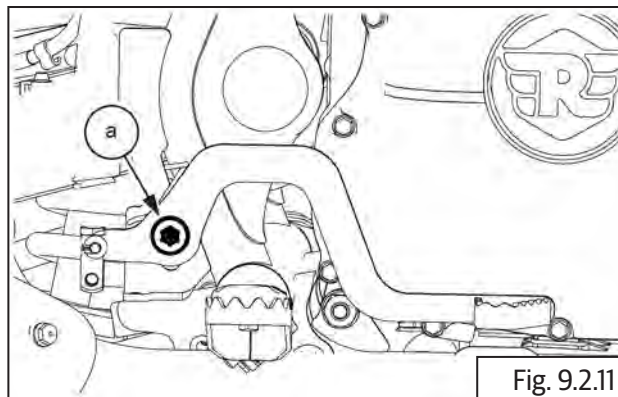

- Remove spring **(a)** from brake pedal **(b)**.

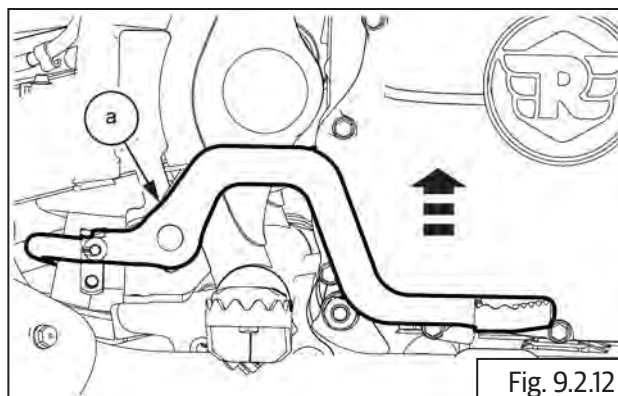

9.2.2. Brake Caliper Assembly - Rear

- Remove the following:
 - Rear wheel spindle and chain adjuster assembly from rear wheel ([section 6.8.3](#)).
- Loosen and remove Hex socket head screw **(M6)** **(a)** located below brake caliper on RH rear wheel to remove wheel speed sensor.

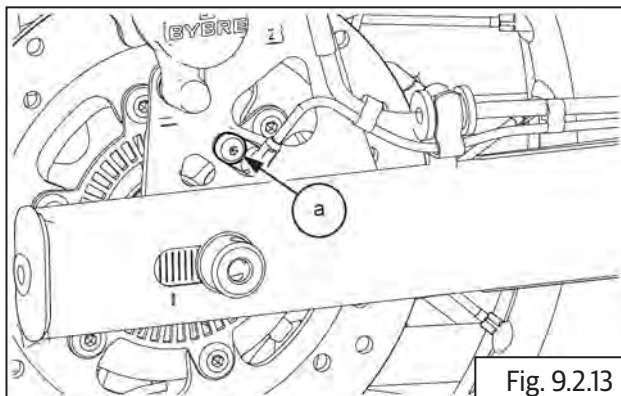

- Gently remove rear wheel speed sensor ABS **(a)** from rear wheel hub.
- Remove brake pad outer clip **(a)** from brake pad lock pin.

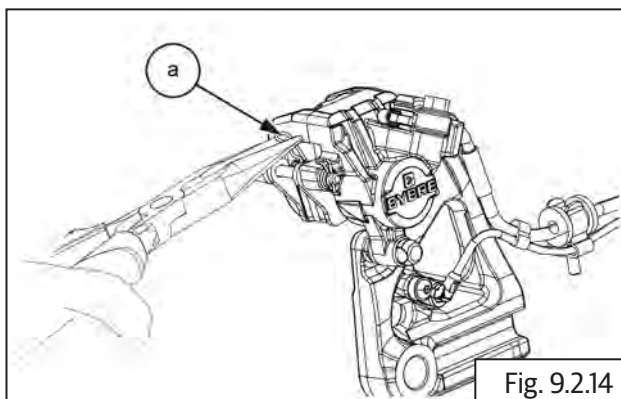

- Remove brake pad inner clip **(a)** from brake pad lock pin.

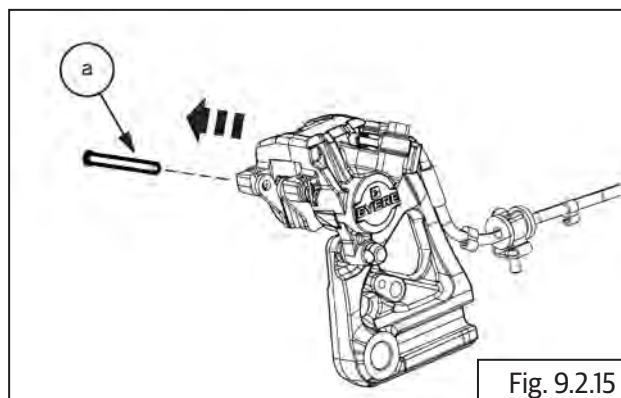

- Slide out and remove brake pads **(a)** from brake caliper.

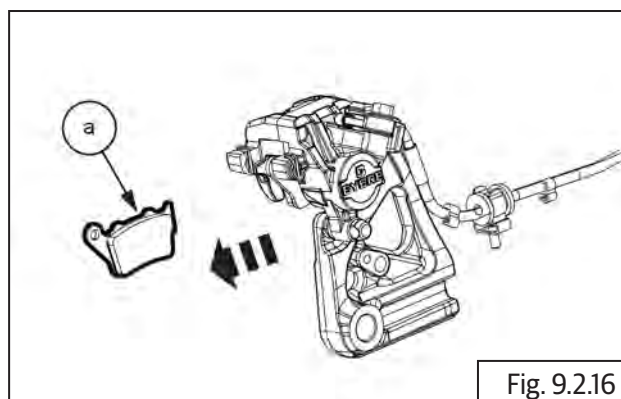

- Slide out and remove brake caliper **(a)** with holder.

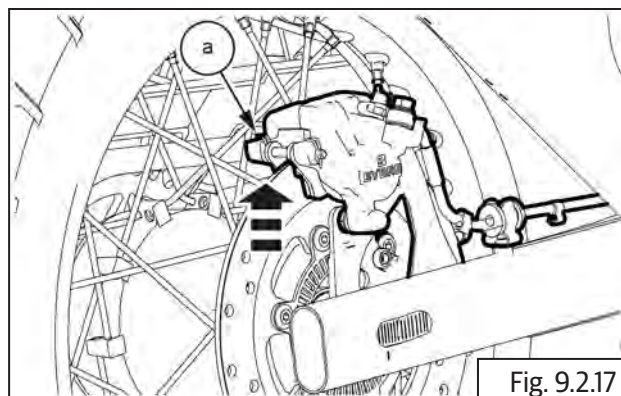

Dismantling Rear Brake Caliper

- Position caliper body with pistons down and apply small squirts of air pressure to the fluid inlet hole to remove pistons.

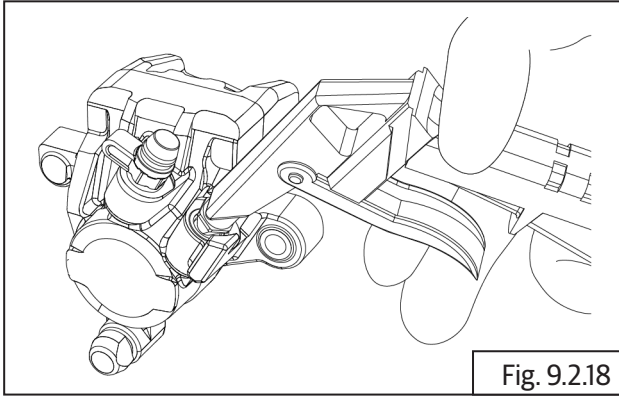

⚠ CAUTION

DO NOT use high pressure air or bring the nozzle too close to the inlet. Place a shop towel over the pistons to prevent the pistons from becoming projectiles. Push the dust seals and piston seals in and lift them out using a blunt tool. Care should be taken to avoid any damage on the bore of the sliding surface.

Enough care should be taken to avoid damages of the piston OD while servicing/handling. Remove the bleed Screw.

9.2.3. Brake Disc - Rear

- Remove drive chain and rear wheel from swing arm ([section 6.8.3](#)).
- Loosen and remove 6 Nos. Allen head bolts (**M6**) (**a**) from rear wheel disc hub RH (**b**).

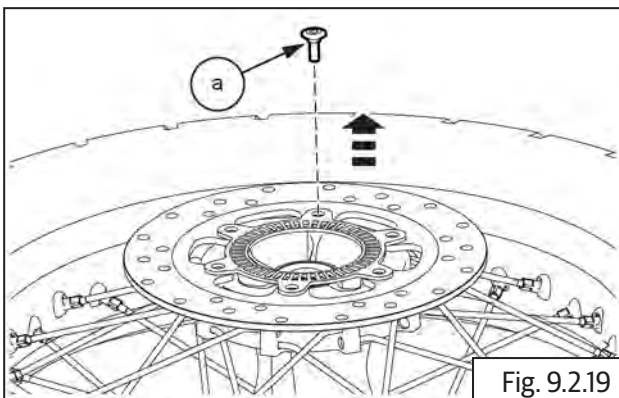

5 mm Allen Socket with Ratchet

- Remove ABS toner wheel (**a**) from rear wheel hub RH.

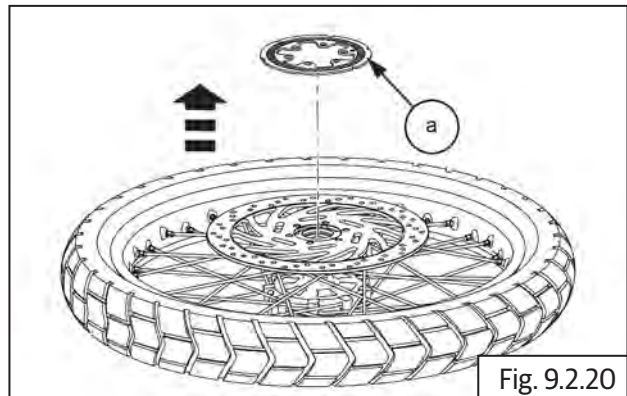

- Remove rear disc plate (**a**) from rear wheel hub RH (**b**) and keep aside safely.

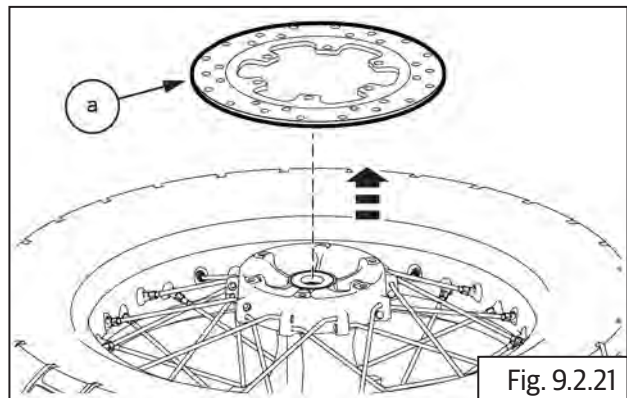

Inspection

- Inspect for rust, deep scoring, any foreign materials, burn marks crack in the mounting location of front and rear brake discs.
- Inspect front and rear brake disc thickness and run-out. Measure depth at points where scoring is found on the discs and replace if there is excess wear. (Need to confirm).

Standard:	0.00 mm
Service limit:	0.10 mm

- Also measure thickness at the points indicated in the illustration and replace disc if out of specifications.

Front brake disc.

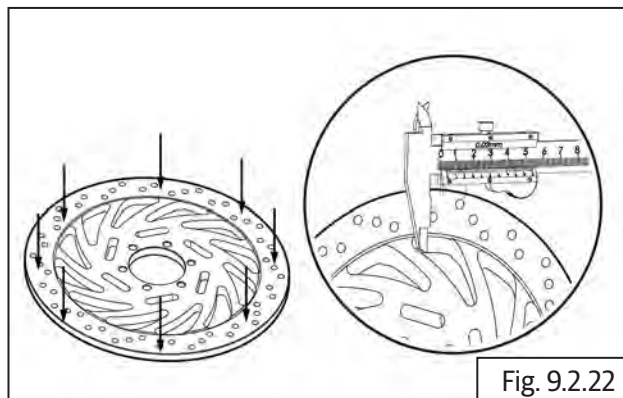

Fig. 9.2.22

Rear brake disc.

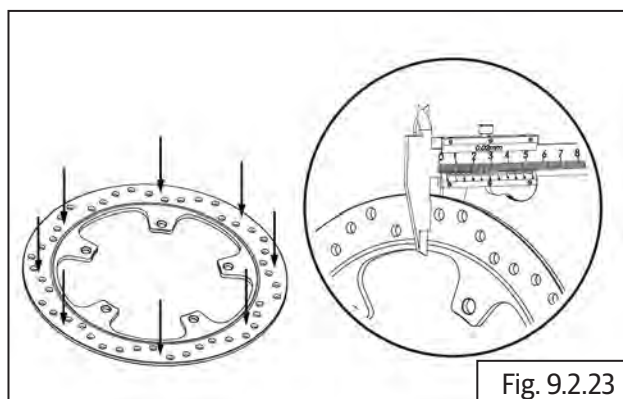

Fig. 9.2.23



Vernier caliper

Service limit:	0.8 mm
----------------	--------

- Place brake disc rotor on a flat surface and inspect warpage. Replace if it is out of specifications.

Front brake disc.

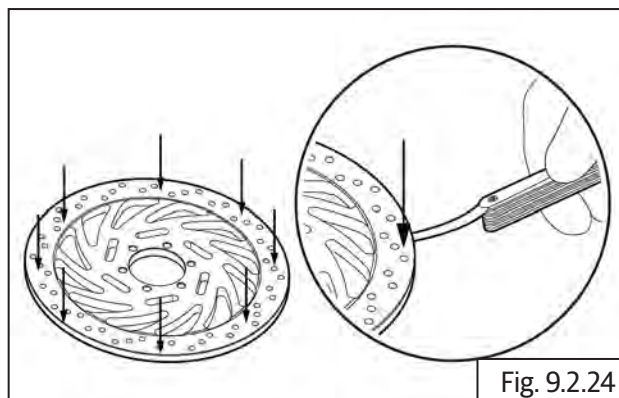

Fig. 9.2.24

Rear brake disc.

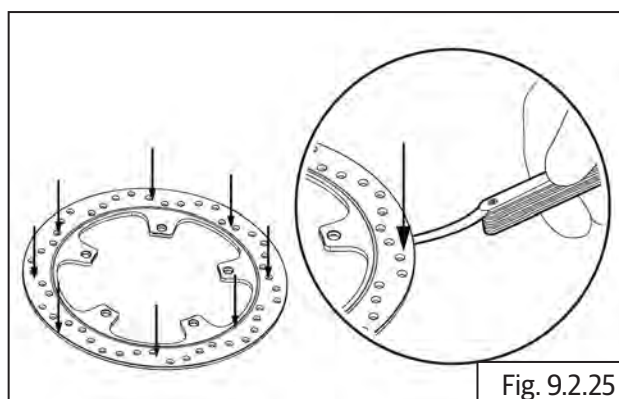
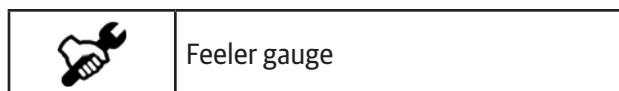

Fig. 9.2.25



Feeler gauge

Standard:	0.00 mm
Service limit:	0.10 mm

- Inspect and replace toner wheel front if there are any damages or bends.
- Place toner wheel front on a flat surface and check warpage. Replace if out of specifications.

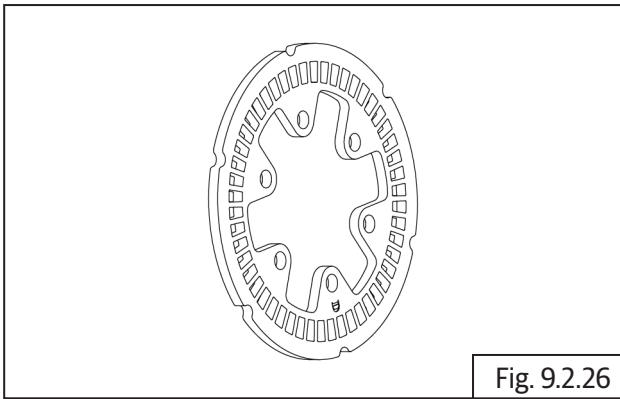

Fig. 9.2.26

- Inspect and replaces toner wheel rear ABS **(a)** if there are any damages bends.
- Place ABS toner wheel on a flat surface and check warpage. Replace if out of specifications.

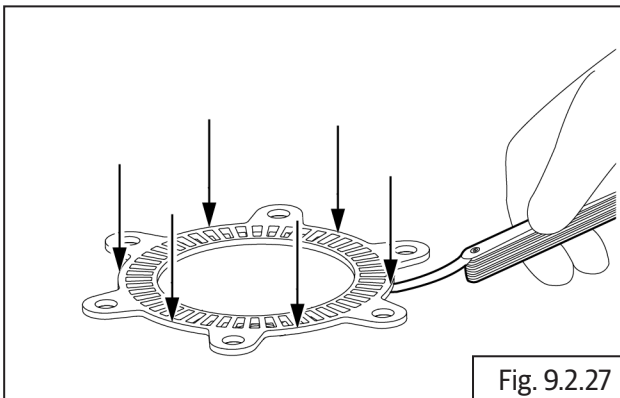

Fig. 9.2.27

	Feeler gauge
---	--------------

Standard:	0.00 mm
Service limit:	0.10 mm

- After assembly of brake disc **(a)** into front wheel, insert spindle into rim, fix on wheel balance frame **(b)** and rotate rim to check the disc run-out with dial gauge **(c)**. Ensure run-out is within specified limits.

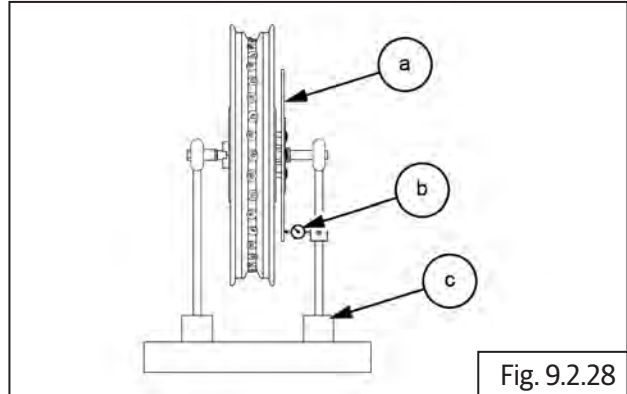



Fig. 9.2.28

	Dial gauge
---	------------

Service limit:	1 mm
----------------	------

⚠ CAUTION
Run-out of brake disc should be checked only when brake disc is assembled on wheel hub.

- Inspect brake pad thickness- front and rear. Replace if worn-out.

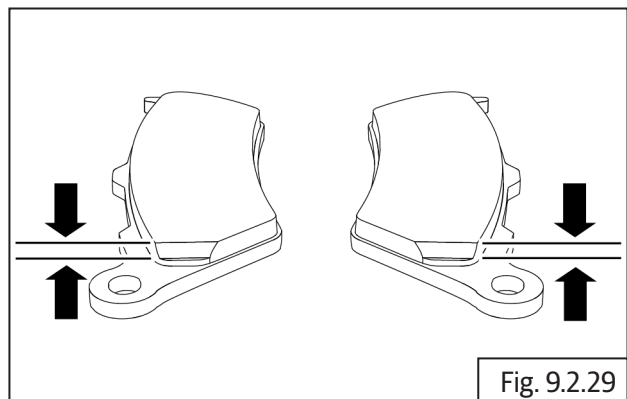
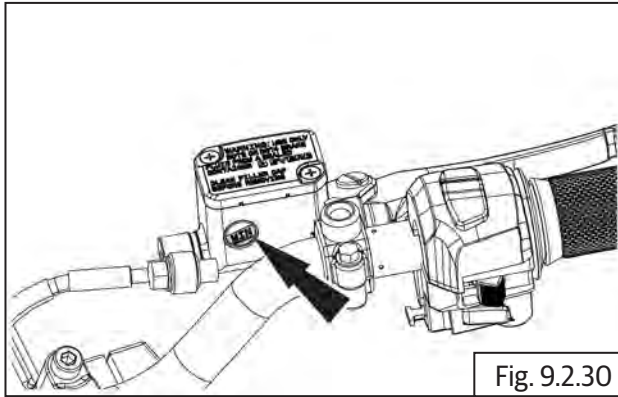

Fig. 9.2.29

- Check brake fluid level and top up if line is below 'MIN' level **(a)**.

Front



Rear

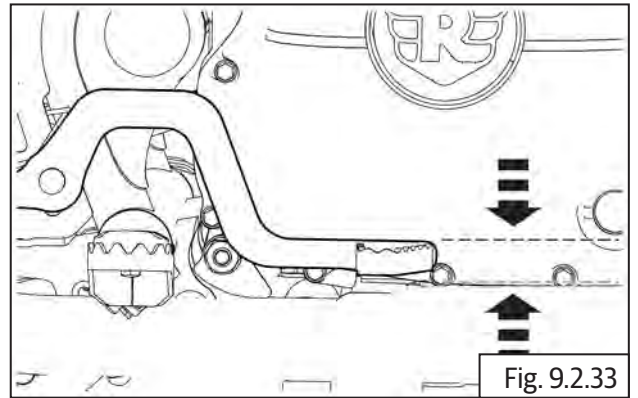

- Inspect and replace front and rear brake hoses **(a)** if they have any cracks, leakages or damages.

Rear

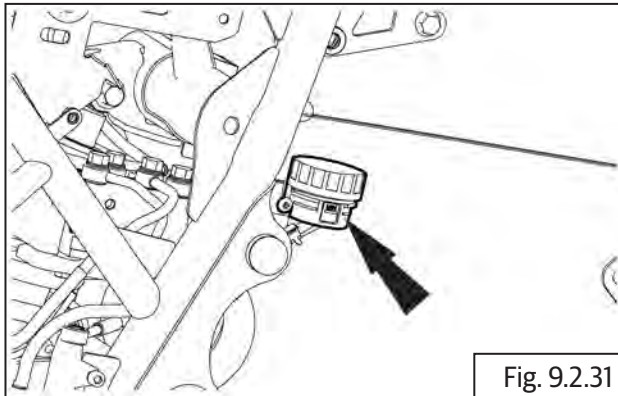

Front

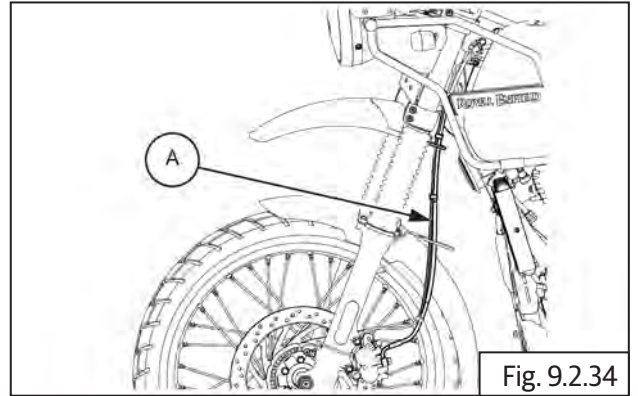

⚠ CAUTION
DO NOT mix DOT 4 and other brake fluids together

- Inspect brake lever front **(a)** free play and brake pedal rear **(b)** free play. If free play is spongy, check brake pads for wear or tear and replace and follow brake bleeding procedure.

Front

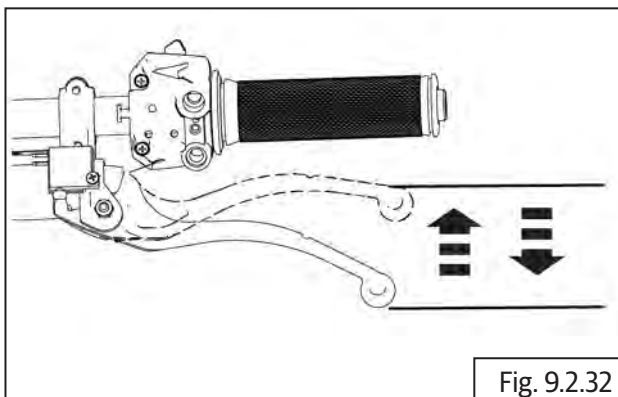

Rear

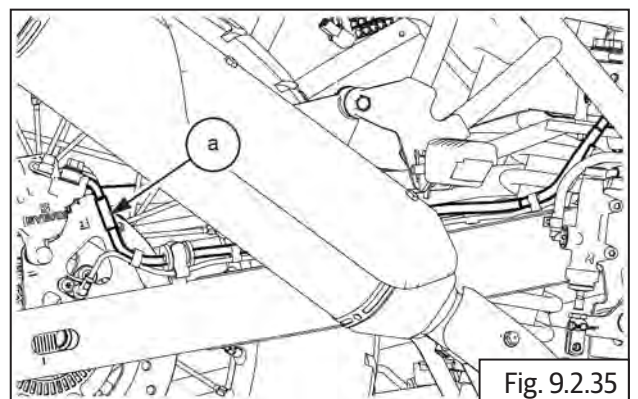

Assembly

Brake - Rear

9.2.4. Brake Disc - Rear

- Assemble rear disc plate **(a)** into rear wheel hub RH **(b)**.

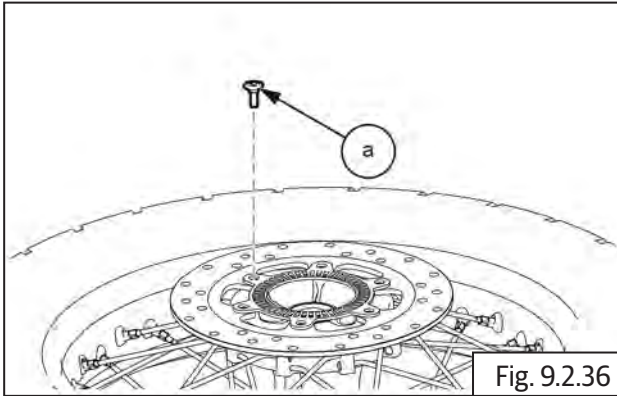

- Assemble ABS toner **(a)** into rear wheel hub RH.

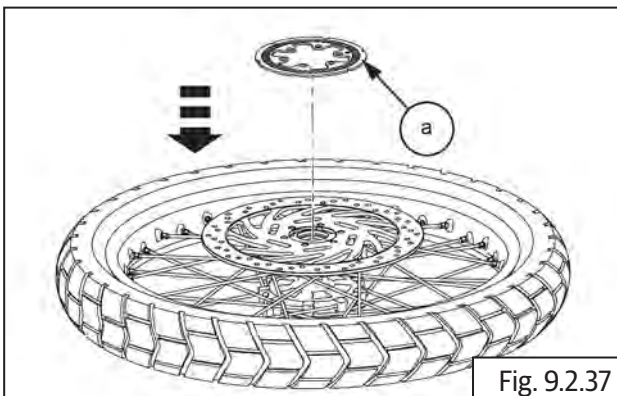

- Insert and tighten 6 Nos. Hex head button socket screws **(M6) (a)** into rear wheel disc hub RH.

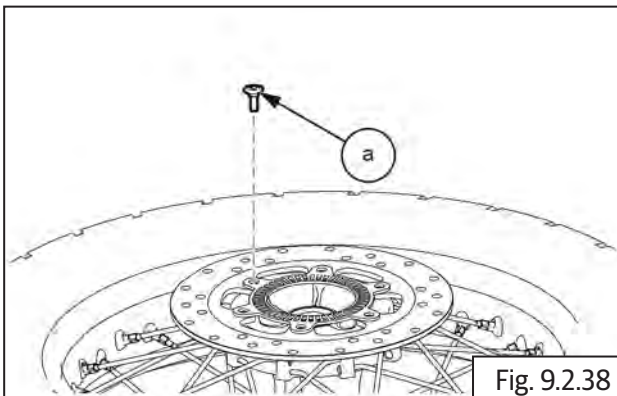

	5 mm Allen socket with Ratchet
Torque	10-12 N-m/1.0-1.2 kgf-m

- Assemble drive chain and rear wheel into swing arms ([section 6.8.8](#)).

9.2.5. Brake Caliper Assembly - Rear

Assembling Rear Brake Caliper

- Coat fresh brake fluid on new dust seals and piston seals.
- Install piston seals in the inner groove **(a)** and dust seals in the outer groove **(b)** in the bore in caliper assembly.

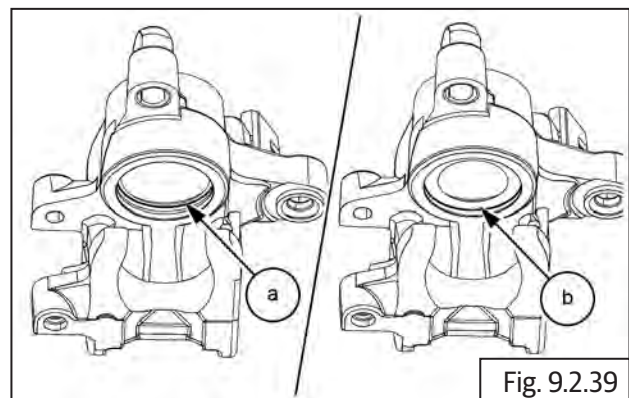

- Coat the caliper cylinder and piston with fresh brake fluid.
- Insert the closed end of the piston **(a)** into the caliper bore and gently press it into caliper fully till the open ends of the piston are flush with the caliper bore outer edge

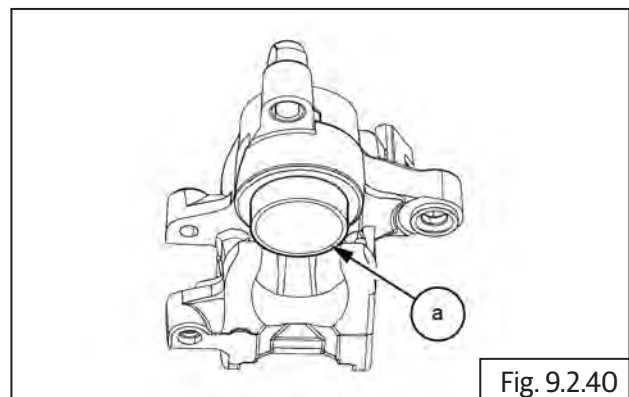

⚠ CAUTION

DO NOT apply force while assembling the piston into the caliper. Press only with minimal hand pressure.

- Assemble the rubber grommets **(a)** on the bracket mounting area of the caliper.

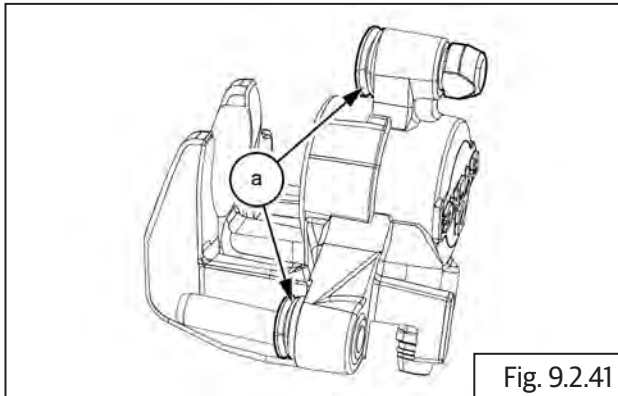

Fig. 9.2.41

- Assemble Bleed screw **(a)** with the dust cap on the caliper body.

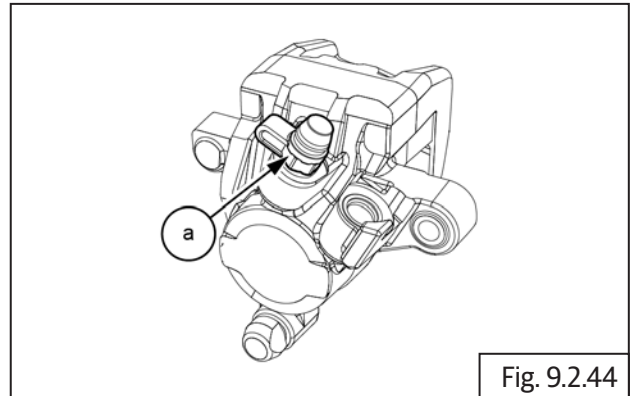

Fig. 9.2.44

- Locate bracket **(a)** on the caliper **(b)** and gently press caliper into bracket fully.

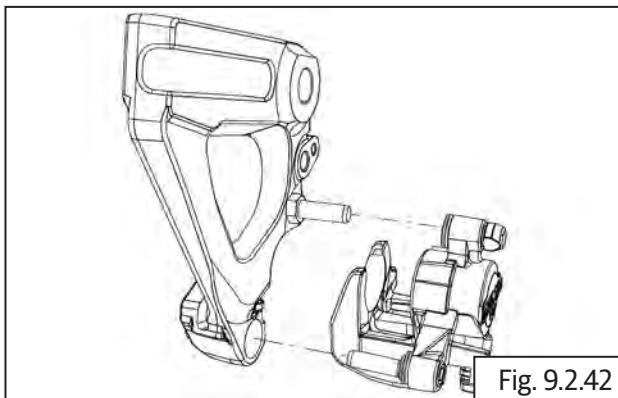

Fig. 9.2.42

- Gently locate brake caliper **(a)** with holder onto brake disc.

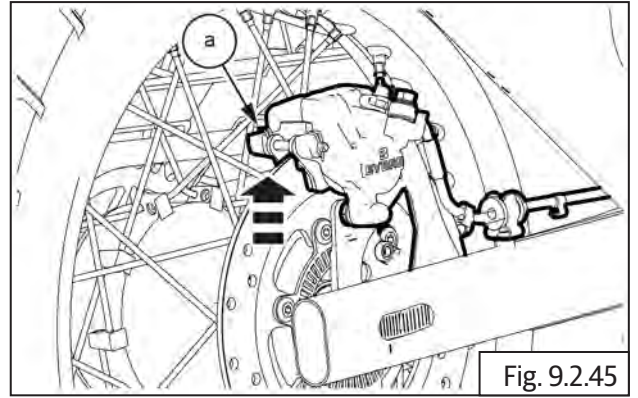

Fig. 9.2.45

- Install the pad tension spring plate **(a)** in the Caliper body.

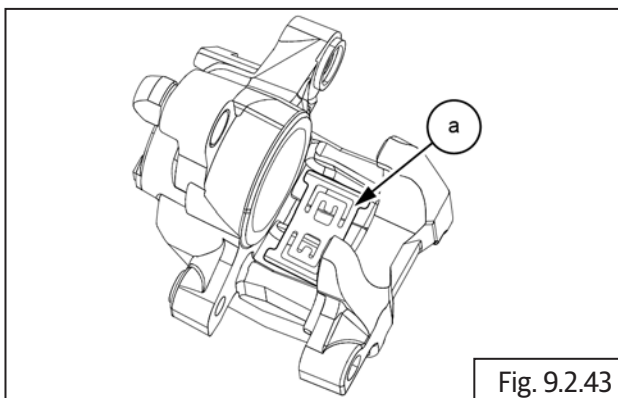

Fig. 9.2.43

Rear Brake Pads in Wheel Caliper

- Gently locate brake pads **(a)** into brake caliper.

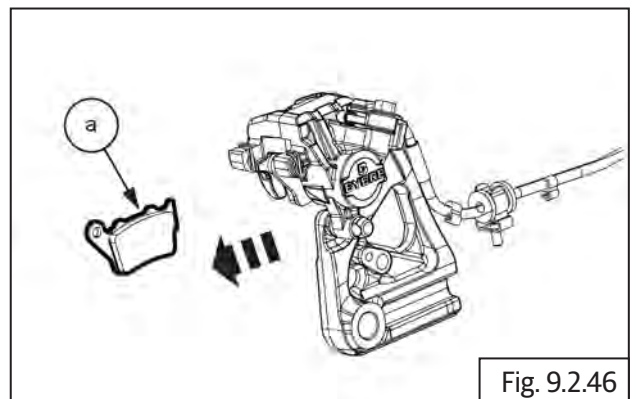
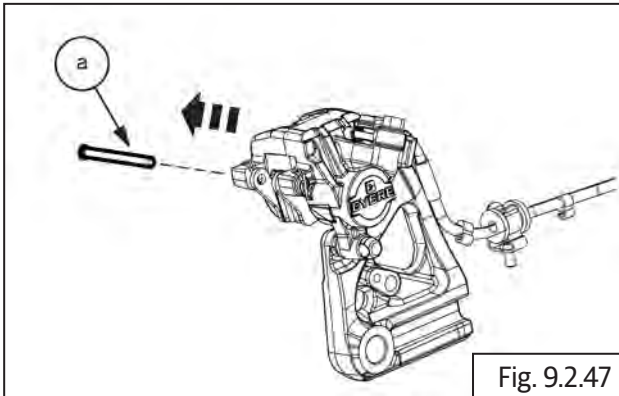
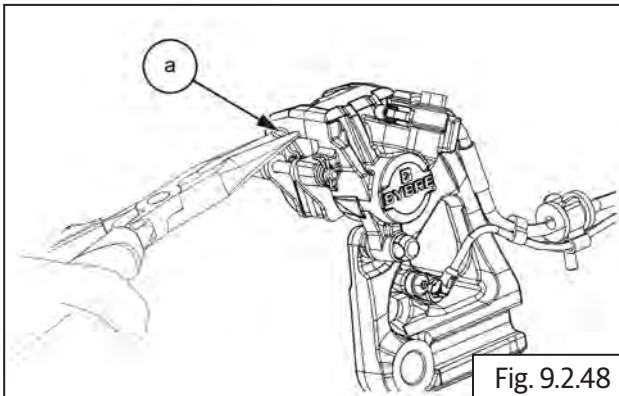

Fig. 9.2.46

- Locate brake pad lock pin **(a)** into brake caliper **(b)**.



- Install brake pad inner clip **(a)** into brake pad lock pin.



- Gently assemble rear wheel speed sensor ABS **(a)** into rear wheel hub.

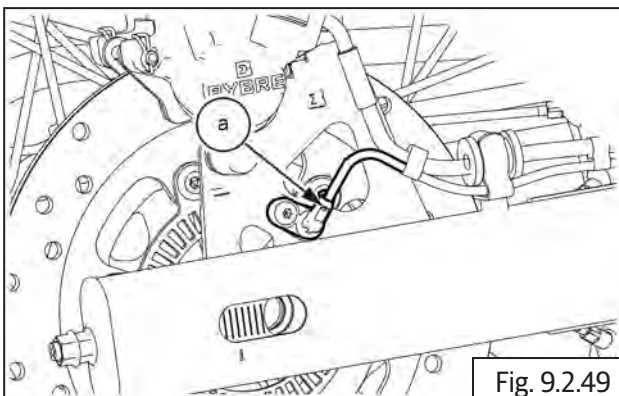

- Locate and tighten Hex socket head screw **(M5)** **(a)** located below brake caliper on rear wheel RH.

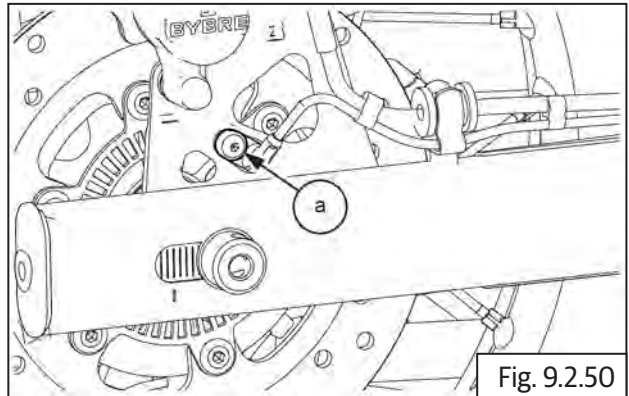

	5 mm Allen socket with Ratchet
Torque	10-12 N-m/1.0-1.2 kgf-m

- Assemble swing arm bolt, spindle and chain adjuster assembly into rear wheel ([section 6.8.8](#)).

9.2.6. Master Cylinder Assembly - Rear

- Locate new O-ring inside the master cylinder bore.

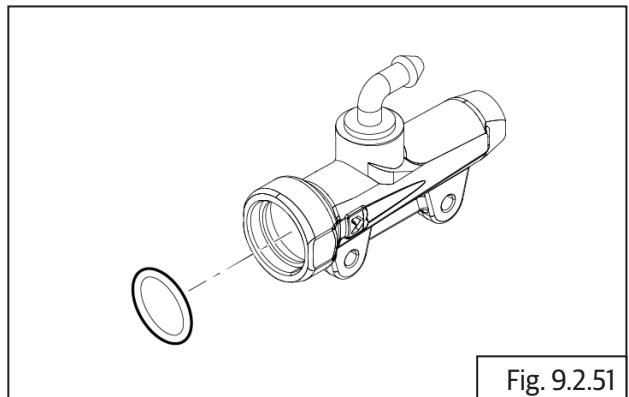

⚠ CAUTION

DO NOT use any sharp tool to assemble the O ring or piston in the master cylinder.

- Assemble spring guide on the small end of spring.
- Locate peg on piston, on spring guide.
- Locate large bush over the piston.

- Insert large end of the spring along with the piston and guide bush into the master cylinder bore and hold it in compressed position inside master cylinder.
- Assemble Circlip **(a)** in the master cylinder body **(b)** and ensure it is locked properly in the groove.

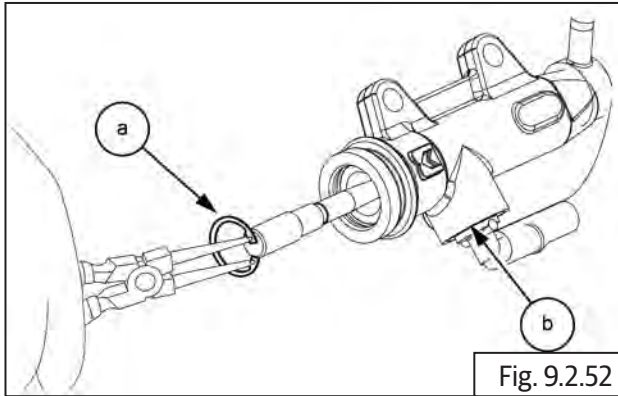

	Circlip plier
--	---------------

- Assemble the protective rubber boot **(a)** on the master cylinder.

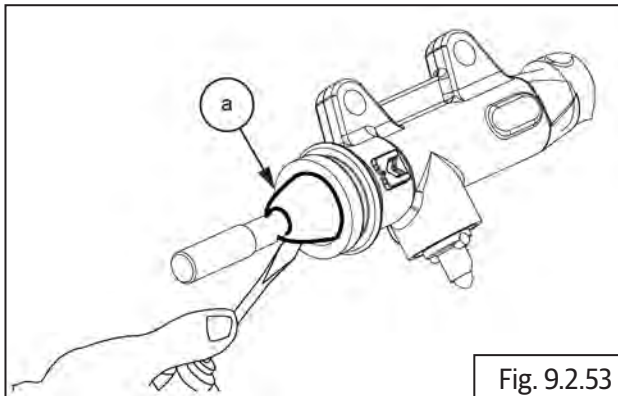

	Screw driver
--	--------------

- Locate master cylinder assembly into frame assembly.
- Insert and tighten 2 Nos. Hex socket bolts **(M6)** **(a)** to fix master cylinder assembly **(b)** into frame.

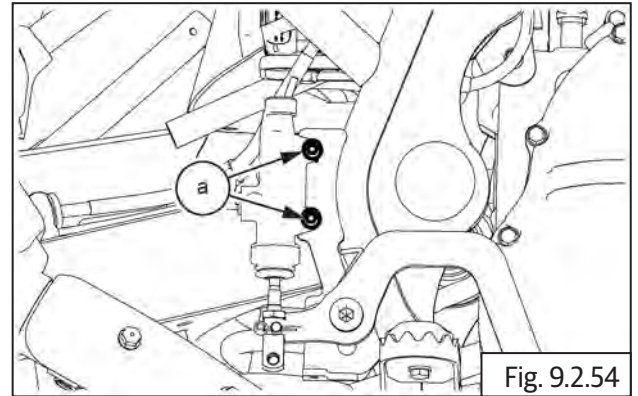

	5 mm Allen socket with Ratchet
Torque	10-12 N-m/1 kgf-m

- Assemble banjo bolt **(a)** along with copper washer **(b)** and brake hose **(c)** in the master cylinder assembly.

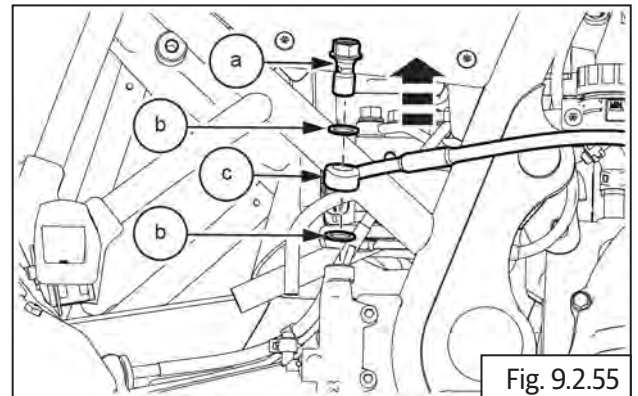

	12 mm Allen socket with Ratchet
Torque	10-12 N-m/1 kgf-m

- Locate and assemble rear brake fluid reservoir **(b)** with allen bolt **(a)** .

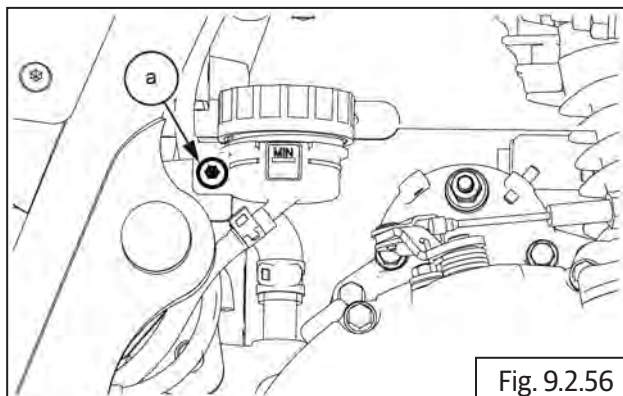

	5 mm Allen socket with Ratchet
Torque	10-12 N-m/1 kgf-m

- Assemble reservoir hose **(a)** in the master cylinder assembly.

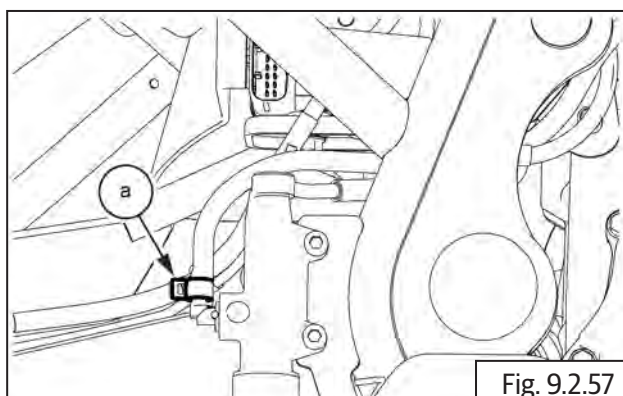

	Nose Plier
---	------------

Rear Brake pedal

- Insert the rear end of the brake pedal **(a)** into the master cylinder **(b)**.

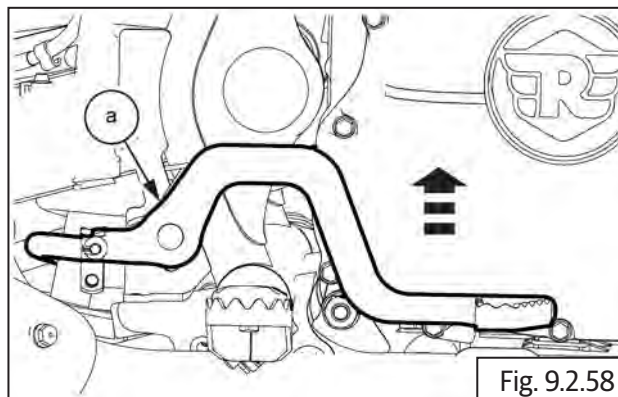

- Locate and tighten brake pedal mounting bolt **(a)**.

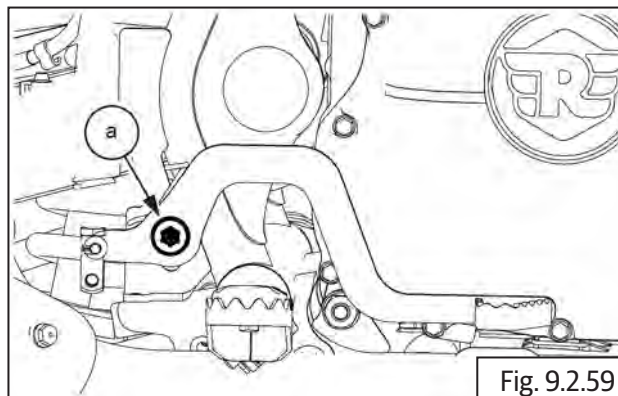

	6 mm Allen socket with Ratchet
Torque	25-35 N-m/2.5-3.5 kgf-m

Brake - Front

9.2.7. Brake Disc - Front

- Locate front brake disc **(a)** on front wheel hub and disc facing outward. Ensure mounting holes are correctly aligned.

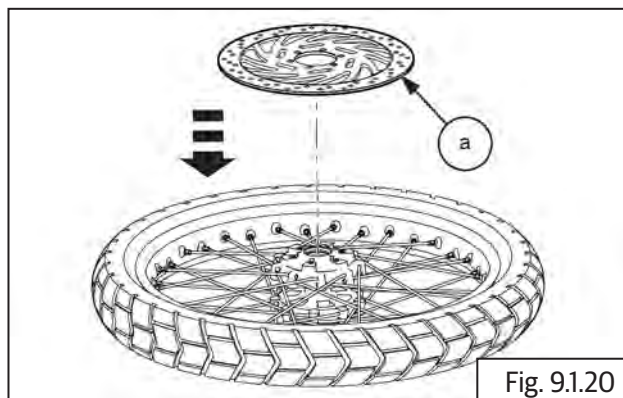

- Position toner wheel **(a)** onto front disc and ensure mounting holes are correctly aligned.
- If bolts are pre-coated bolts replace with new ones.
- If they are non-coated, clean threads and wait for few minutes and apply thread sealant.

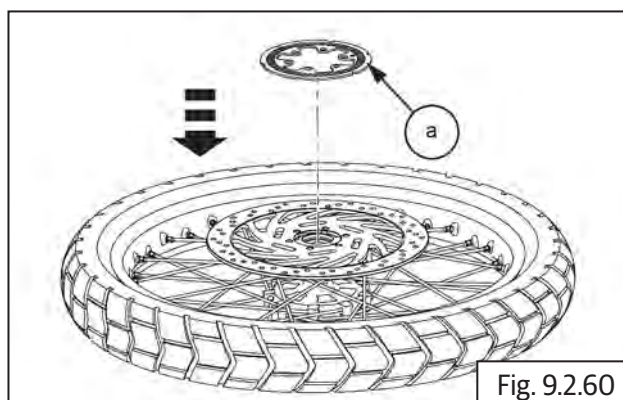

- Insert 5 Nos. Hex socket head bolts **(M8) (a)** into brake disc LH and tighten in criss cross pattern to specified torque.

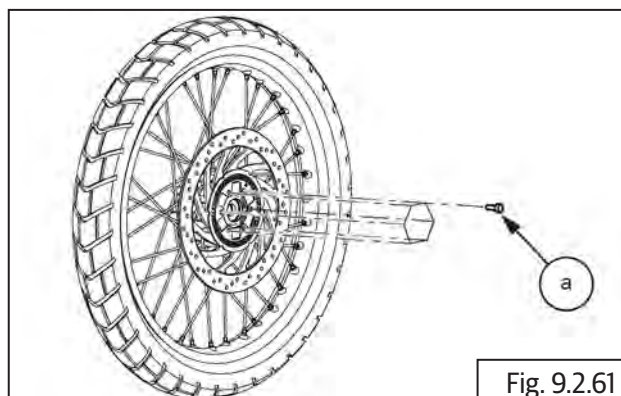

	6 mm Allen socket with Ratchet
Torque	25 N-m/2.5 kgf-m

- Assemble front wheel into front fork assembly ([section 6.8.13](#)).

9.2.8. Brake Caliper - Front

- Coat fresh brake fluid on new dust seals and piston seals.
- Install piston seals in inner groove **(a)** and dust seals in outer groove **(b)** in the bore in caliper assembly.

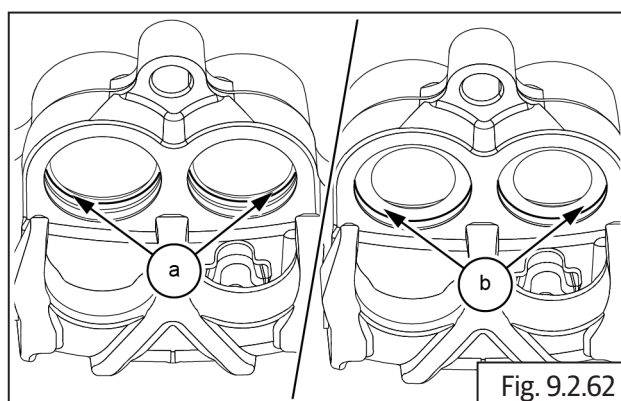

- Coat the caliper cylinders and pistons with fresh brake fluid.

- Insert closed end of the pistons into caliper bores and gently press it into caliper fully till open ends of the piston **(a)** are flush with caliper bore outer edge.

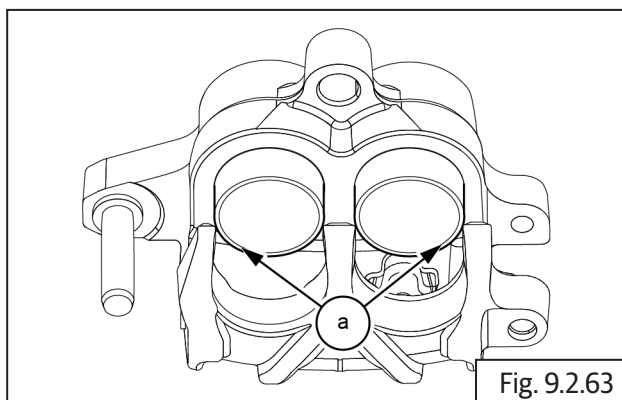

NOTE

- Do not apply force while assembling the pistons into the caliper. Press only with minimal hand pressure. Assemble pistons one at a time into the caliper.

- Smear fresh brake fluid on the caliper boot and bellow and assemble them on the caliper body.

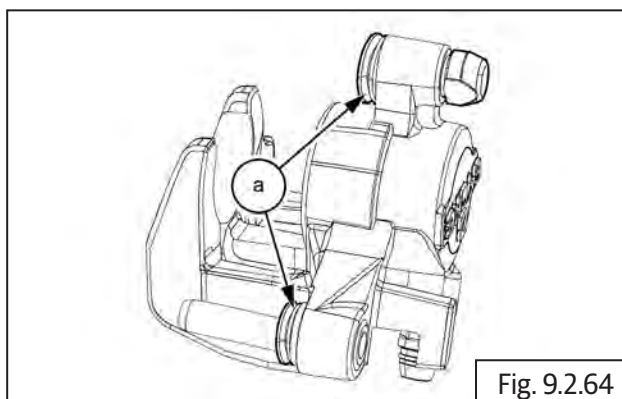

- Install pad tension spring plate **(a)** in caliper body.

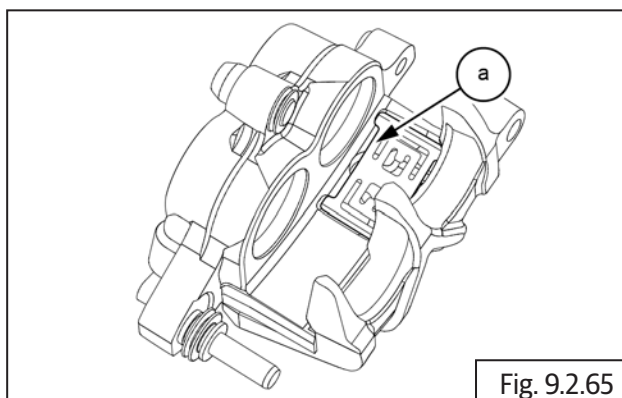

- Assemble bleeder valve **(a)** with dust cap on the caliper body.

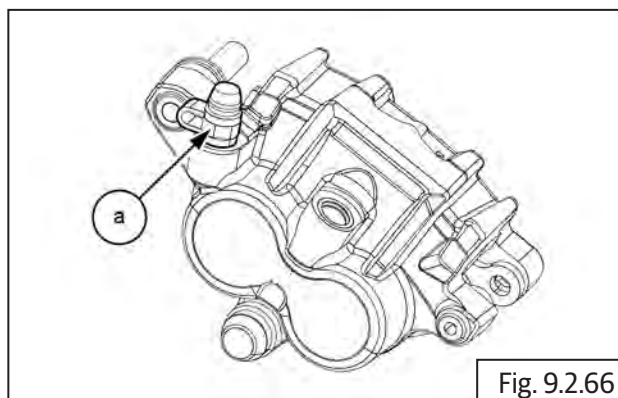

- Assemble the mounting bracket **(a)** on caliper body **(b)**.

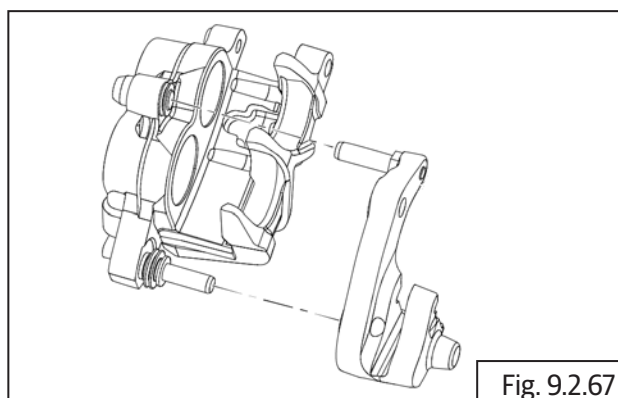

- Slide in and assemble brake pads **(a)** into brake caliper **(b)**.

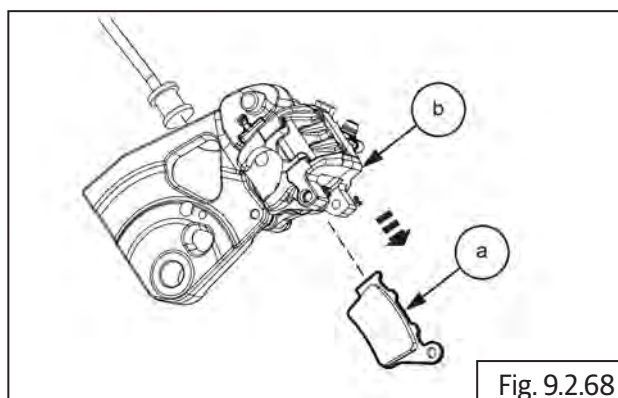

- Lubricate and insert brake pad pin **(a)** into caliper.

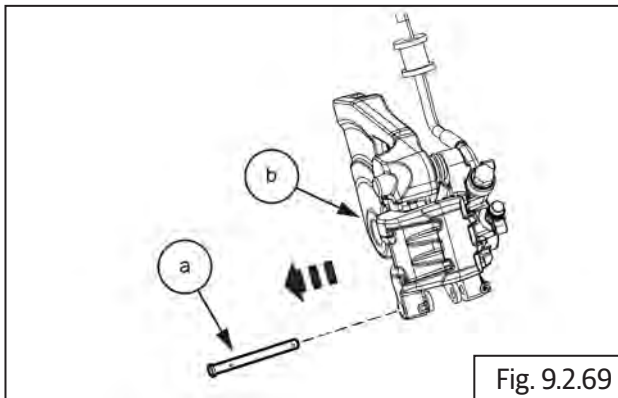

- Suitably support caliper and correctly tap brake pad pin **(a)** from outside to inside.

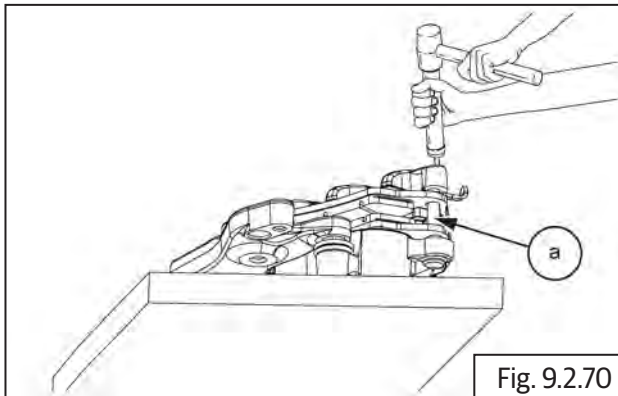

- Assemble brake pad lock clip **(a)** into the brake pad pin **(b)**.

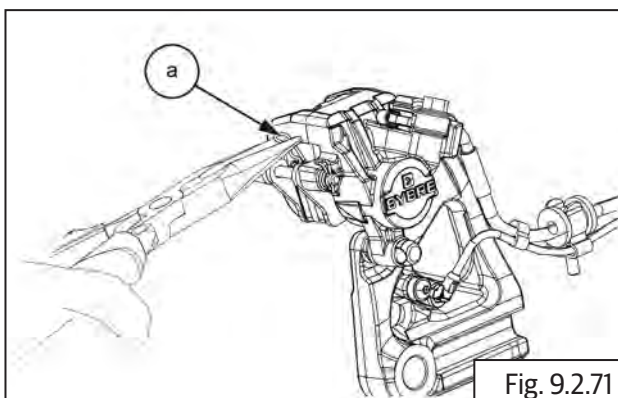

- Support and hold the front brake caliper assembly suitably onto the front LH fork.
- Locate and tighten upper and lower Hex flange head bolts **(M10) (a)** to fix front brake caliper assembly **(b)** to LH fork.

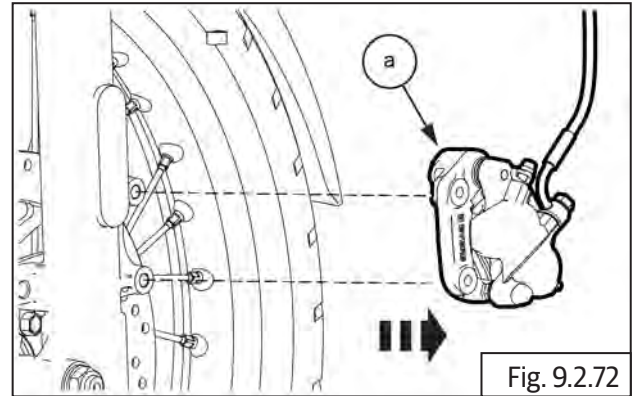

	14 mm Socket with Ratchet
Torque	45 N-m/4.5 kgf-m

- Gently install hose into caliper assembly ([section 9.3.10](#)).

9.2.9. Master cylinder - Front

- Locate the conical spring **(a)** on the piston **(b)**.

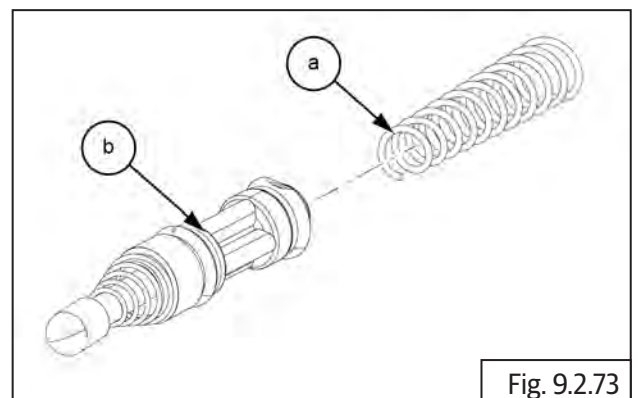

- Smear piston seals and cylinder bore with fresh brake fluid and assemble piston **(a)** subassembly into master cylinder **(b)** by gently pushing it into the bore.

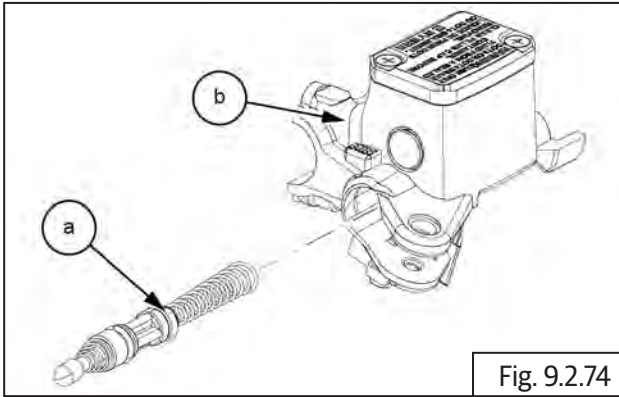

- Compress and assemble circlip **(a)** into groove of master cylinder **(b)**.

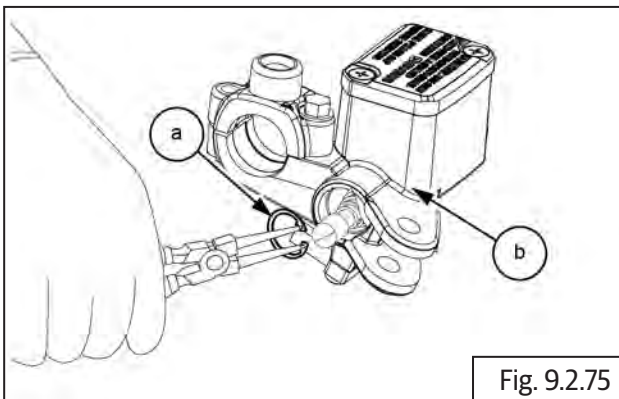

⚠ CAUTION
DO NOT use tools with sharp ends.
Ensure circlip is locked properly after assemble.

- Assemble the rubber Boot **(a)** in the master cylinder **(b)**.

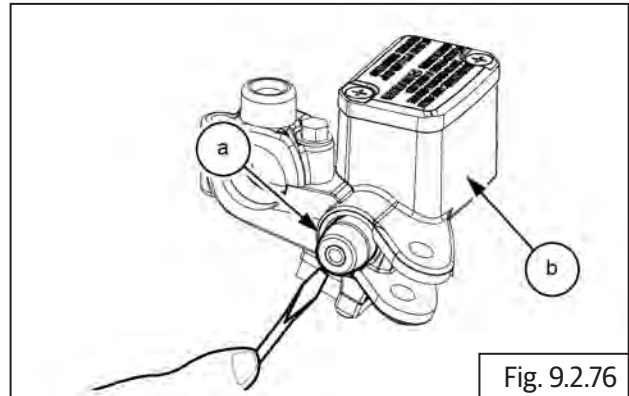

- Apply silicon grease on the lever pivot hole and on the Piston surface.
- Position brake lever inside the bracket, locate pivot screw from the top and tighten to bracket.
- Assemble lock nut below and tighten.

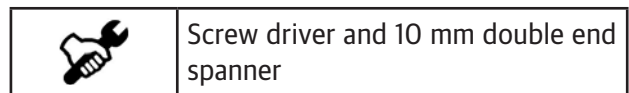
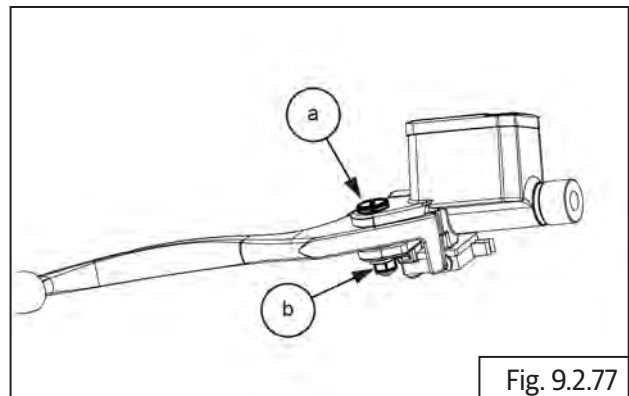

- Assemble the Brake Switch on the bracket.

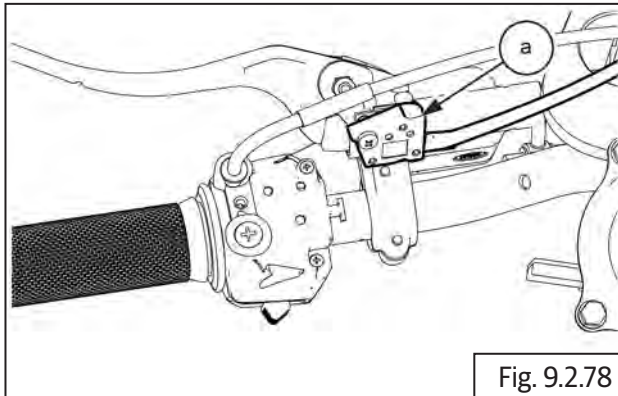

Fig. 9.2.78

- Locate master cylinder assembly on handlebar RH and locate clamp over cylinder.
- Locate and tighten 2 Nos. Hex flange head bolt **(M5) (a)** into clamp and fix the master cylinder assembly.

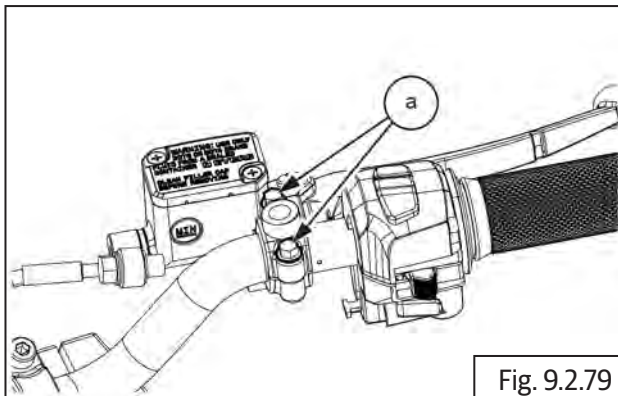



Fig. 9.2.79

	8 mm Socket with Ratchet
Torque	10-12Nm/1.0-1.2 kg/f

- Assemble banjo bolt **(a)** holding the brake hose **(b)** to front master cylinder to ABS modulator.

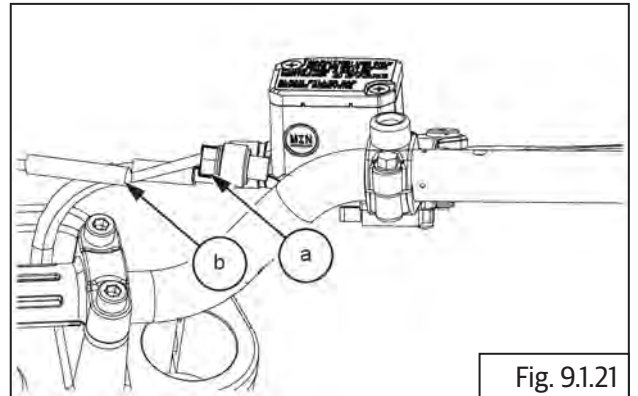



Fig. 9.1.21

	12 mm Socket with Ratchet
Torque	10-12Nm/1.0-1.2 kg/f

- Refill fluid, inspect and diagnose if there are any leakages ([section 9.8](#)).

9.3 Anti-lock Braking System (ABS)

Working Principle

The Royal Enfield Meteor 350 motorcycle is equipped with the state of the art Anti-Lock Braking System (ABS).

The ABS is a safety system which constantly receives inputs about the speed of rotation of the front and rear wheels on a real time basis and modulates the braking force for each wheel when brakes are applied by the rider. This helps prevent the brakes from locking the wheels, especially when brakes are applied suddenly, the wheels have a better traction with the road surface.

The benefits of ABS:

- Increased braking efficiency and riding confidence when braking.
- Prevent wheel lock up when brakes are applied suddenly with great force thereby ensuring good traction of the front and rear wheels with the road surface.

Typical Motorcycle Braking Distance

(Average driver starting speed 100 Kmph)

The ABS consists of an Electronic Control Unit (ECU), modulator, toner rings and wheel speed sensors.

The ECU constantly receives inputs on the speed of rotation of the front and rear wheels through the wheel speed sensors. When the rider applies either the front or rear brakes or both brakes, the speed sensors provide data on the rate of deceleration of the wheels to the ECU which then commands the valves in the modulator to progressively regulate the hydraulic fluid pressure on a real time basis so that the brake pads do not "lock" on the brake disc which can potentially cause the wheels to lock.

Whenever front and/or rear brakes are applied with great force/suddenly, the braking management system gets input of the wheels speed through a wheel speed sensor and commands the modulator in the braking system to modulate the hydraulic fluid force such that the brake pads do not lock on the brake disc which effectively from locking and provide better traction to prevent the motor cycle from shifting and/or loss of control.

In the ABS, during application of brakes, a pulsating sensation will be felt on the brake lever/pedal indicating that the ABS is working correctly.

⚠ WARNING

The ABS will by no means prevent an accident and/or loss of control. It is the responsibility of the rider to anticipate and judge the braking distances required, depending on the speed at which the motorcycle is traveling and apply brakes sufficiently in advance to prevent an accident and/or loss of control.

While ABS assists in improved motorcycle control during braking, decreased stopping distances on dry and good road conditions, it cannot be assumed that it will be effective in wet, rainy, snow covered, off road conditions, loose gravel surfaces or hilly roads etc, as the traction of the wheel itself will be very minimal in these conditions.

As far as possible, whenever applying sudden brakes in emergency in wet conditions, please ensure the motorcycle is upright in steady riding position and the handlebars are straight. Avoid hard braking when banking heavily at great speeds.

Whenever brakes are applied, a pulsating sensation will be felt on the brake lever/pedal. This is characteristic to the ABS and quite normal, as the modulator in the ABS constantly modulates the hydraulic pressure in the braking system in relation to the force applied on the brake lever/pedal and the speed of the motorcycle.

Whenever bleeding the hydraulic system, it is highly recommended to bleed both the front and rear brakes for proper functioning of the ABS. Do not restrict to bleeding any one brake system as it may render the ABS non-functional, in case the other brake has air bubbles in its system.

Functions and Specifications of the ABS Aggregates

As soon as the ignition and engine stop switch are switched ON, the ABS sign will light up. The lamp will remain ON till the motorcycle attains a speed of 5 Km/h (3MPH) and then switches OFF. This indicates that the ABS is working properly.

In the event the lamp does not switch OFF and remains continuously ON at higher speeds, it is recommended not to drive the motorcycle and get the brake system inspected and corrected through a nearest authorized Royal Enfield Dealer / Distributor.

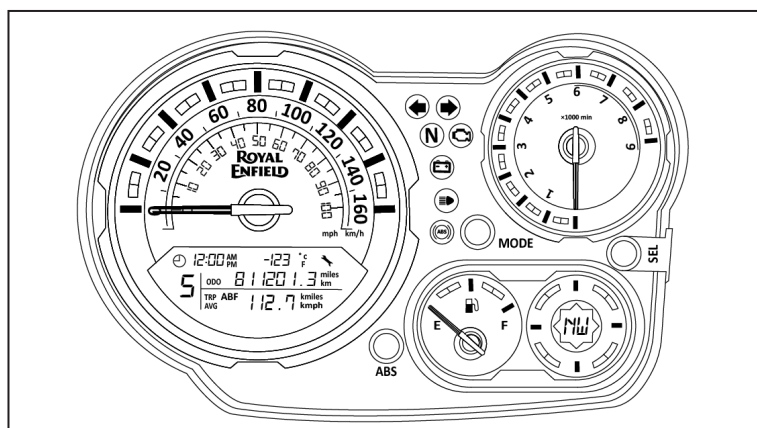

1. Electronic Control Unit (ECU)

The ECU is located in the bracket alongside of the modulator, on the frame, behind the battery.

It consists of a microprocessor, which receives inputs from the wheel speed sensors, interprets the data, determines the safe hydraulic pressure in relation to the speed of the wheels and commands the valves in the modulator to progressively regulate the hydraulic fluid pressure on a real time basis for efficient and safe braking.

Specifications:

Operating Voltage: 9 V to 16 V

Operating Temperature: -40°C to 70°C

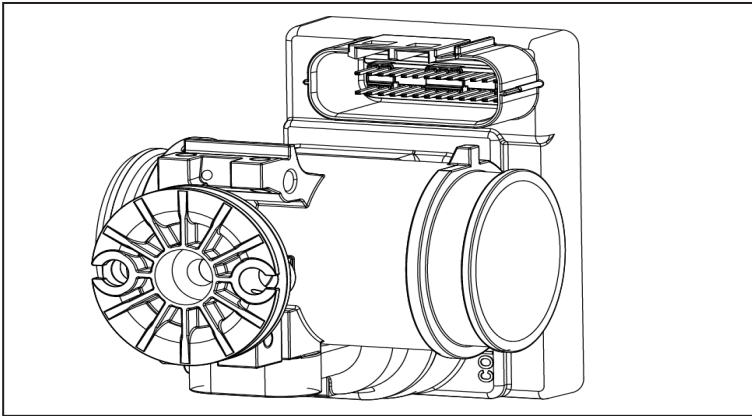

The ECU also records and stores data on the performance of the ABS on a real-time basis. This will help in diagnosing any braking related disorders, whenever the Royal Enfield NACS II diagnostic tool is connected to the socket in the wiring harness of the motorcycle.

The history stored in the ECU can also be saved to an external computer for future reference and also erased from the ECU, using the Royal Enfield NACS II diagnostic tool.

2. Modulator

The modulator is located on the frame below the fuel tank. The brake hoses from the master cylinders and brake calipers are connected to the modulator.

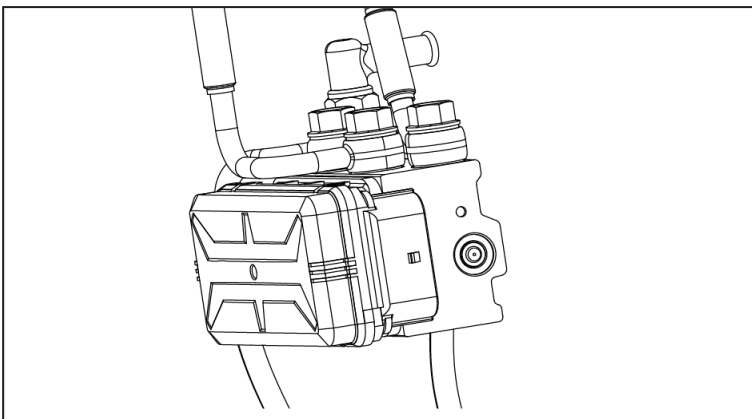

Whenever brakes are applied, the valves inside the modulator are progressively activated by the ECU to regulate the hydraulic fluid pressure in the brake system. This in turn will modulate the movement of the pistons inside the brake calipers to prevent the brake pads from locking on the brake discs.

3. Wheel Speed Sensors, Front and Rear

There are 2 wheel speed sensors provided in the motorcycle. The front speed sensor is assembled on the fork end LH and the rear speed sensor is assembled on the rear wheel caliper bracket.

Specifications:

Operating Voltage: 08 V to 16 V

Operating Temperature: -40° C to 70° C

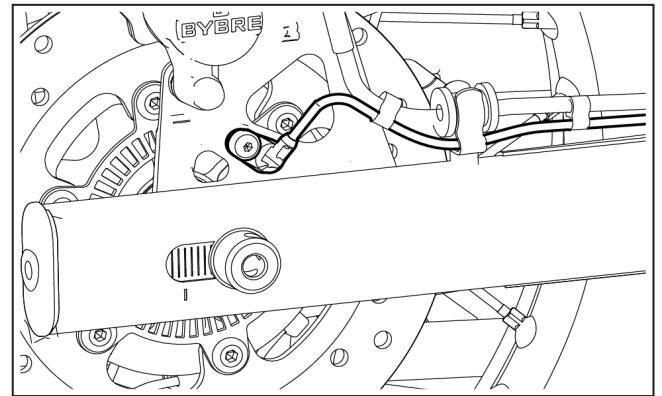
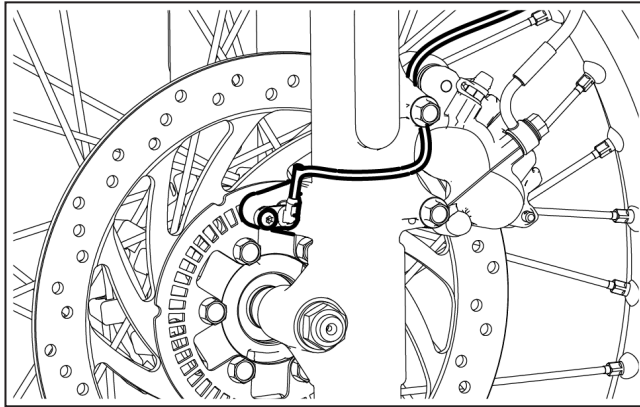

These sensors provide the inputs to the ECU about the speed of rotation of the wheels.

4. Toner Rings, Front and Rear

The toner rings are assembled on the front and rear brake hubs inside the brake discs.

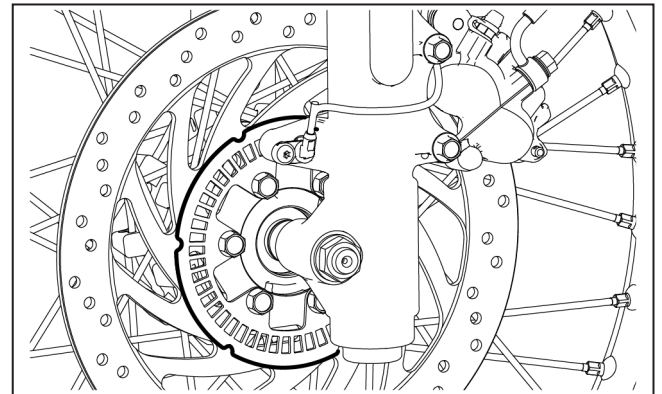
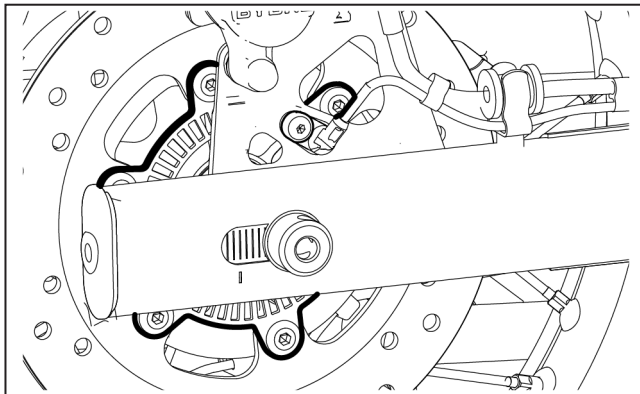

The toner rings assist the wheel speed sensors to assess the speed of rotation of the wheels.

5. Master Cylinders, Front and Rear

The front brake master cylinder is assembled on the handlebar RH and activated by the front brake lever.

The rear brake master cylinder is assembled on the frame RH side and activated by the brake pedal

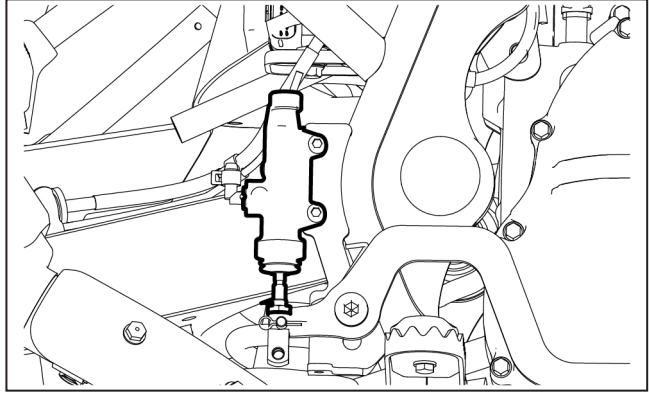
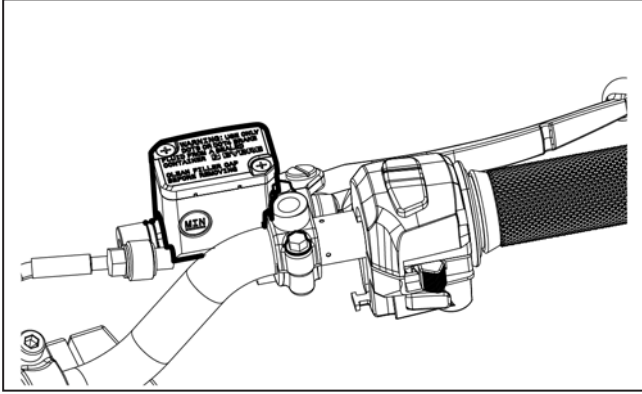

Whenever the front brake lever/rear brake pedal are activated, the piston inside the master cylinder applies force on the brake fluid to activate the brakes.

The master cylinders are connected to the modulator through brake hoses to transmit the applied hydraulic fluid pressure from the master cylinders.

6. Wheel Calipers - Front and Rear

The front wheel caliper is assembled on the fork end RH and the rear wheel caliper is located on the rear swing arm RH. The wheel calipers consist of pistons and brake pads.

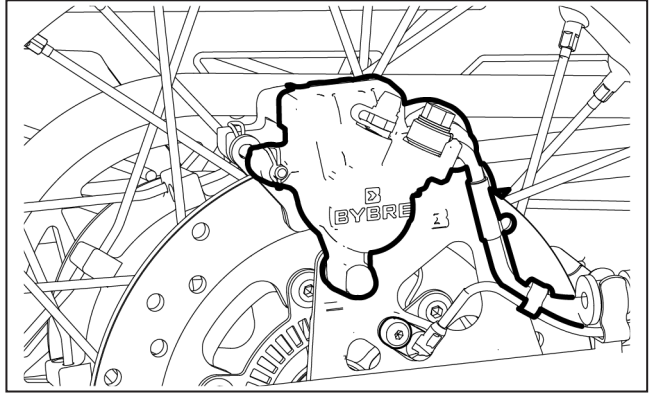
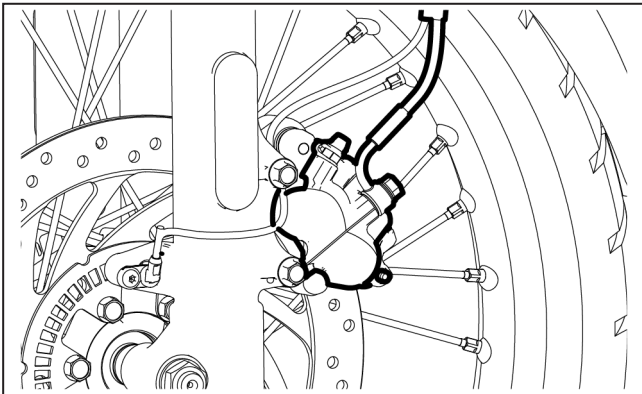

When brakes are applied, the hydraulic fluid force in the braking system causes the pistons to move, and pushes the brake pads against the brake discs on the wheels for braking.

The wheel calipers are connected to the modulator which modulate the hydraulic fluid force to be applied against the pistons.

Do's and Don'ts for ABS

- **Use only approved Brake fluid recommended by Royal Enfield. (DOT4)**
- **Whenever the modulator is removed from the motorcycle, please ensure it is stored upright with the ports facing upwards.**
- **Whenever the modulator is removed from the motorcycle for any reason, please ensure the front and rear brake system bleeding is carefully done and no air is trapped in the brake system.**
- **DO NOT interchange ABS unit/ECU from one motorcycle to another.**
- **DO NOT interchange the brake hose connections between master cylinders and wheel cylinders and also front and rear circuit, at the modulator end.**
- **The shelf life of a wet modulator unit is 5 years from the date of manufacture.**

Dismantling

9.3.1. Modulator

⚠ CAUTION

Before dismantling the modulator, ensure ignition switch and engine stop switch are in OFF position.

Ensure the hydraulic brake fluid from the front and rear brakes is drained completely.

• Remove the following parts:

- Side panel RH ([section 6.7.1](#)).
- Rider seat ([section 6.7.2](#)).
- Fuel tank assembly ([section 7.1.15](#)).

⚠ CAUTION

Ensure the following:

Fuel is drained completely from fuel tank.

Fuel feed and return hoses are disconnected from the fuel rail.

Wiring couplers to fuel pump and low fuel sensors are disconnected.

EVAP hose pipes are disconnected.

⚠ WARNING

Gasoline is extremely flammable and highly explosive. Improper handling can lead to fatal accident or serious injury.

- Bleed out the brake fluid from the front brake system ([section 9.4](#)).

⚠ CAUTION

Do not spill brake fluid on any part of the motorcycle as it will damage the painted/plastic surfaces.

⚠ WARNING

Ensure brake fluid does not get in contact with eyes and skin. In-case of exposure wash affected area thoroughly with water. Seek medical attention immediately if any irritation persists.

Keep out of reach of children.

Dispose drained brake fluid carefully and responsibly.

- Loosen and remove banjo bolt (a) and disconnect hose (b) from front caliper on front fork LH.

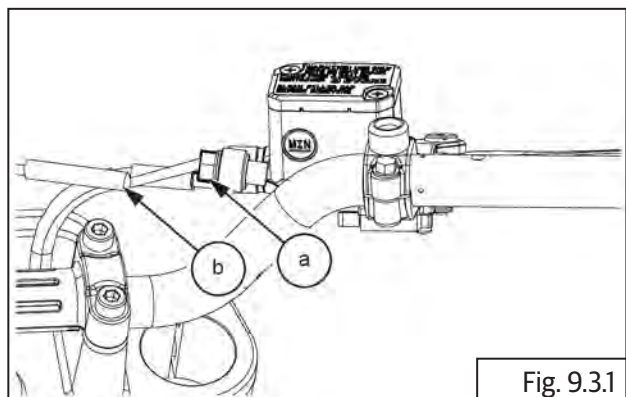

Fig. 9.3.1



12 mm Ring spanner

- Loosen and remove banjo bolt (a) and disconnect hose (b) from front master cylinder on handlebar RH.

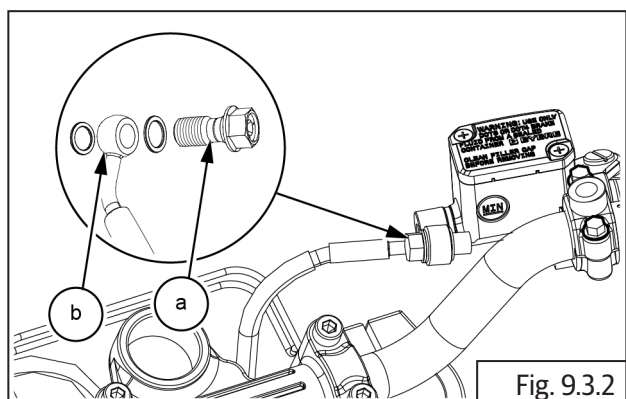

Fig. 9.3.2



12 mm Ring spanner

- Loosen and remove banjo bolt **(a)** along with washers **(b)** and disconnect hose **(c)** from rear caliper from rear wheel RH.

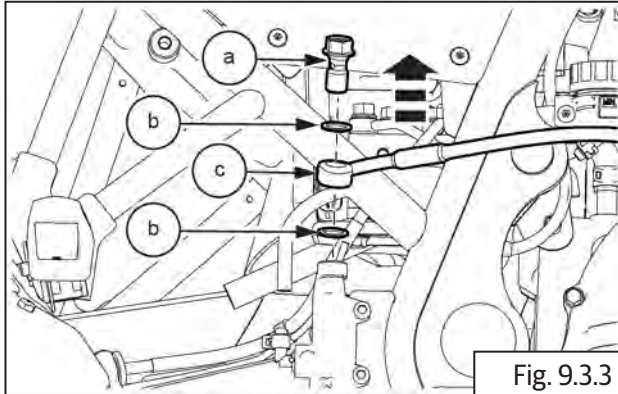

Fig. 9.3.3



12 mm Ring spanner

- Remove brake hose mounting clamps front **(a)** from frame.

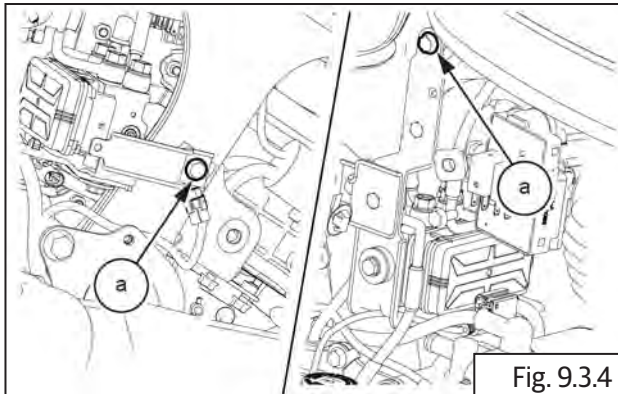

Fig. 9.3.4

- Disconnect holding straps **(a)** of the brake hoses to the frame/fork end/swing arm.

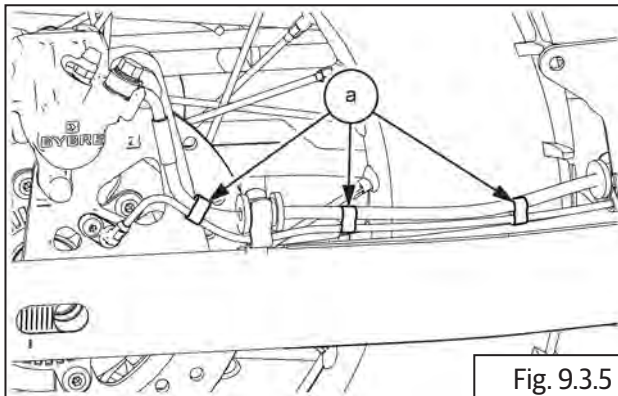

Fig. 9.3.5

- Disconnect ABS modulator electrical connector **(a)** from ECU.

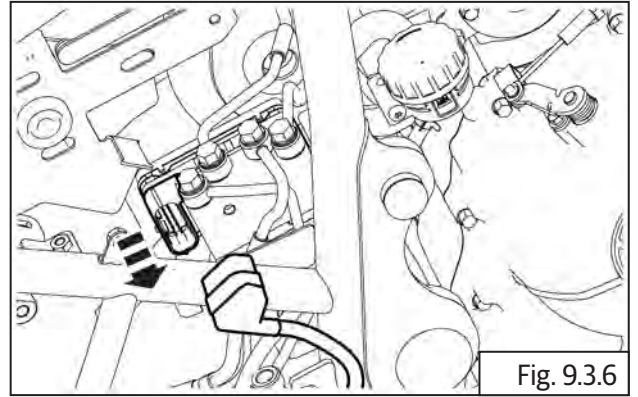

Fig. 9.3.6

- Disconnect front wheel speed sensor wiring connector **(a)** from harness.

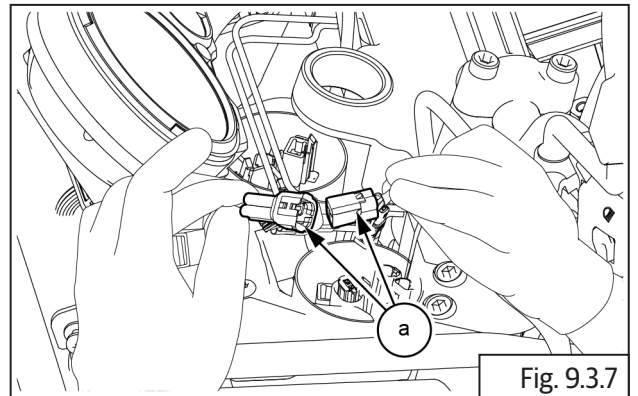

Fig. 9.3.7

9.3.2. Wheel Speed Sensor - Front

- Ensure Ignition switch and Engine stop switch are in OFF position.
- Release sensor coupler wire from the brake hose clip on fork end LH and from the bracket on the frame.

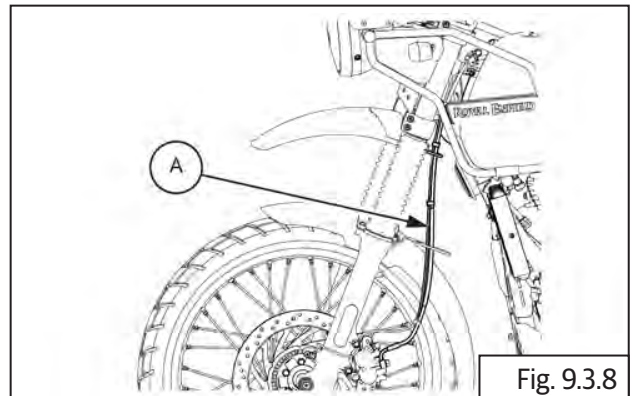

Fig. 9.3.8

- Disconnect sensor coupler **(a)** from harness.

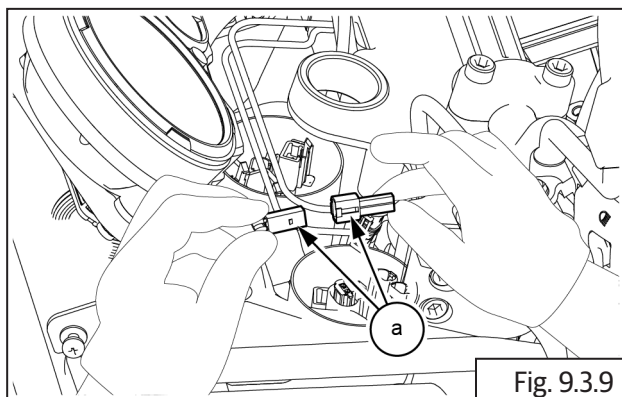

Fig. 9.3.9

- Loosen and remove hex socket head bolt **(M6) (a)** holding sensor to fork end LH.
- Gently pull out sensor from fork end LH.

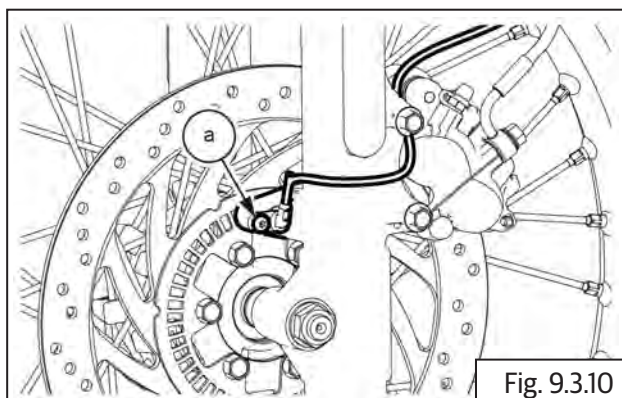

Fig. 9.3.10



5 mm Allen socket with Ratchet

9.3.3. Wheel Speed Sensor - Rear

- Ensure Ignition switch and Engine stop switch are in OFF position.
- Remove the following parts:
 - Side panel RH ([section 6.7.1](#)).
 - Rider seat ([section 6.7.2](#)).
 - Disconnect battery terminals and remove battery from battery carrier ([section 11.5.1](#)).

- Release sensor coupler wire from the routing in mudguard **(a)** and brake hose clip on swing arm RH.

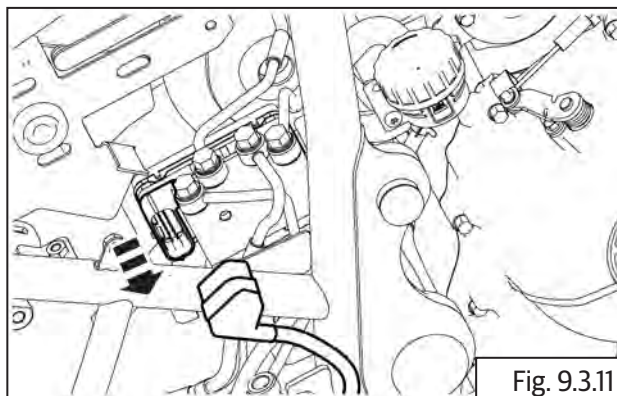

Fig. 9.3.11

- Loosen and remove hex flange head bolt **(M6) (a)** holding sensor to rear wheel caliper bracket top.

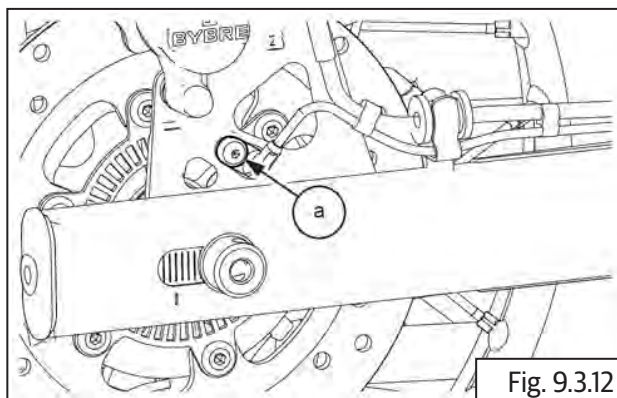

Fig. 9.3.12



5 mm Allen socket with Ratchet

- Gently pull out sensor **(a)** from rear wheel caliper bracket top.

9.3.4. Toner Ring - Front

- Refer front wheel removal ([section 6.8.2](#)).

9.3.5. Toner Ring -Rear

- Refer rear wheel removal ([section 6.8.4](#)).

Assembly

9.3.6. Toner Ring - Front

- Refer front wheel assembly ([section 6.8.12](#)).

9.3.7. Toner Ring -Rear

- Refer rear wheel assembly ([section 6.8.8](#)).

9.3.8. Wheel Speed Sensor - Rear

- Locate and tighten hex flange head bolt (**M6**) (**a**) holding sensor (**b**) to rear wheel caliper bracket top.

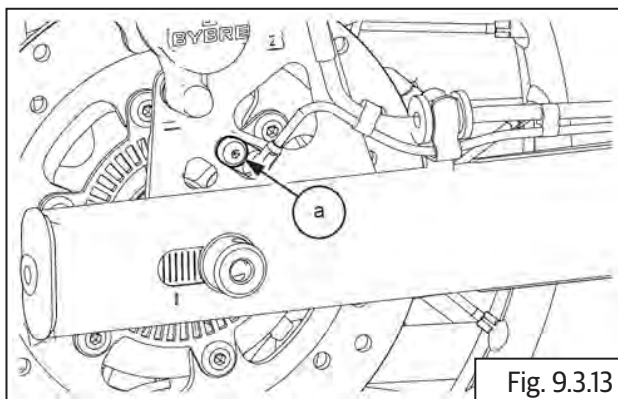

	5 mm Allen socket with Ratchet
Torque	3 N-m/0.3 kgf-m

- Locate battery into battery tray ([section 11.8.3](#)) and connect battery terminals ([section 11.8.4](#)).
- Assemble the following
 - Side panel RH ([section 6.7.8](#)).
 - Rider seat ([section 6.7.7](#)).

9.3.9. Wheel Speed Sensor - Front

- Gently locate sensor onto fork end LH.
- Locate and tighten hex flange bolt (**M6**) (**a**) holding sensor (**b**) to fork end LH.

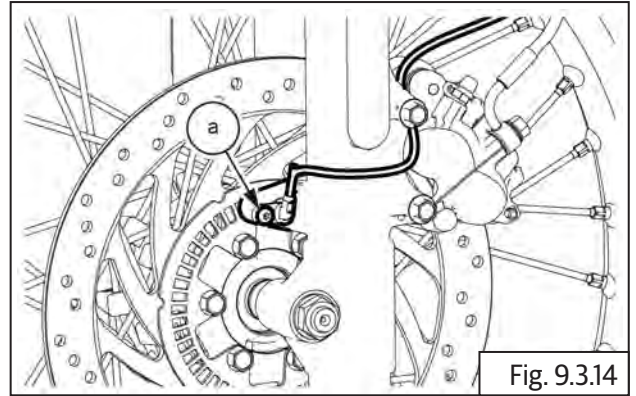

	5 mm Allen socket with Ratchet
Torque	3 N-m/0.3 kgf-m

- Locate sensor coupler wire mounting clamps front (**a**) into frame.

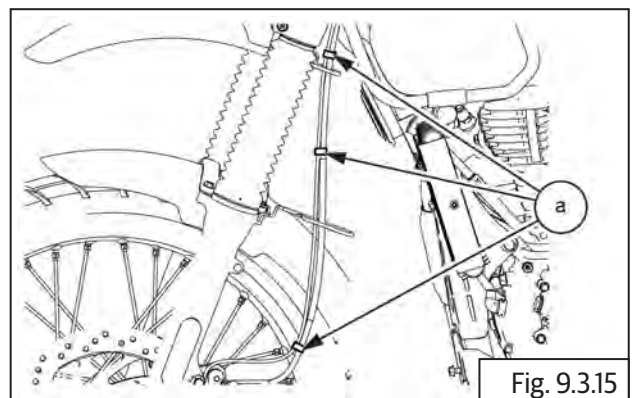

- Connect sensor coupler (**a**) into harness.

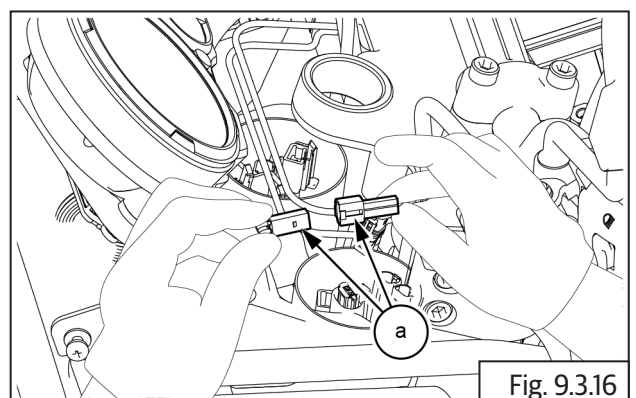

⚠ WARNING

DO NOT interchange ABS unit/ECU from one motorcycle to another.

9.3.10. Modulator

- Brake hose color tags:
 - a) BLUE - Front Master Cylinder Assembly
 - b) GREEN - Front Brake Caliper
 - c) RED - Rear Brake Caliper
 - d) YELLOW - Rear Master Cylinder Assembly
- Ensure the sequence of the hoses is as per the color tags shown below.

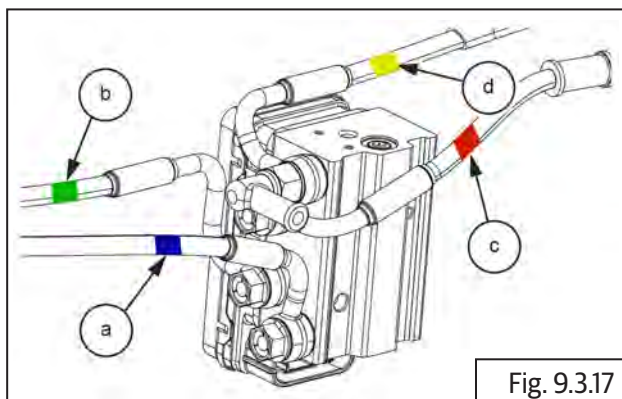

Fig. 9.3.17

- Locate 4 Nos. brake hoses into modulator.
- Support modulator suitably on a work table, keeping the color tags in mind, locate and tighten 4 Nos. banjo bolts **(a)** along with washers into modulator to fix brake hoses **(b)**.
- Ensure the reference marks to align properly.

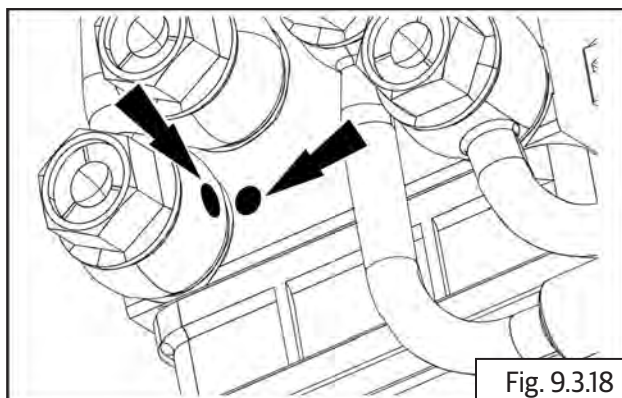

Fig. 9.3.18

- Repeat the above process to other brake hoses.
- RED - Modulator to rear brake caliper hose.

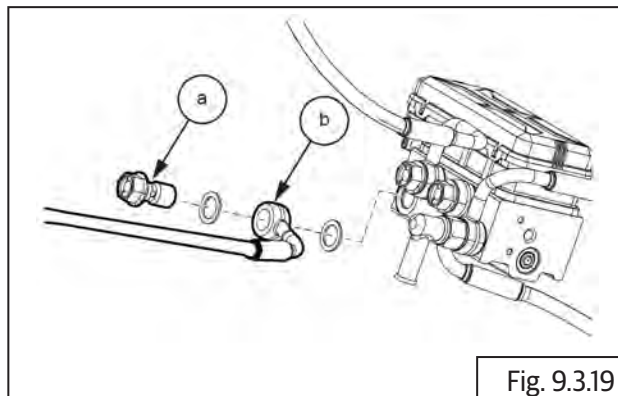

Fig. 9.3.19

- YELLOW - Modulator to rear master cylinder assembly hose.

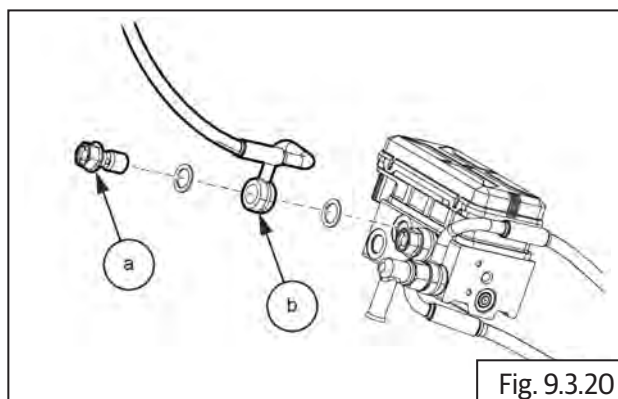

Fig. 9.3.20

- GREEN - Modulator to front brake caliper hose.

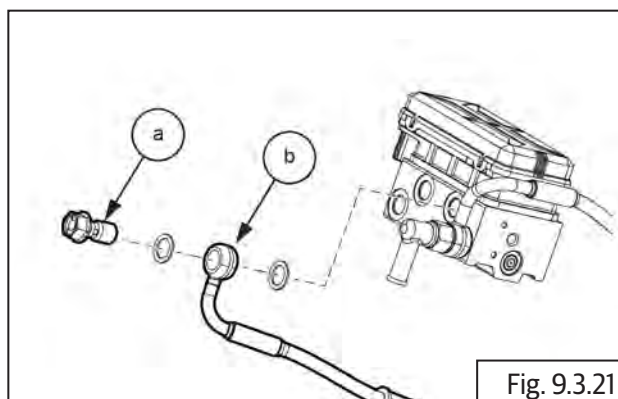

Fig. 9.3.21

- BLUE - Modulator to front master cylinder assembly hose.

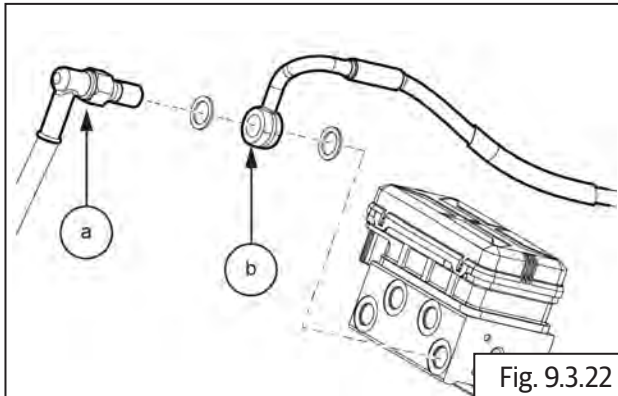

Fig. 9.3.22

- Connect front wheel speed sensor wiring connector **(a)** into harness.

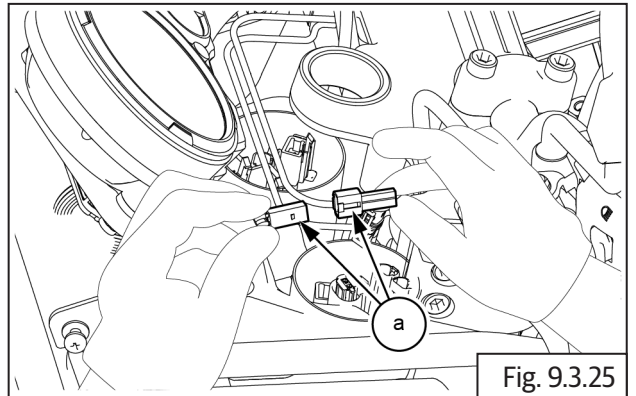

Fig. 9.3.25

- Locate the ABS modulator **(a)** into bracket **(b)** along with 4 Nos. brake hoses.

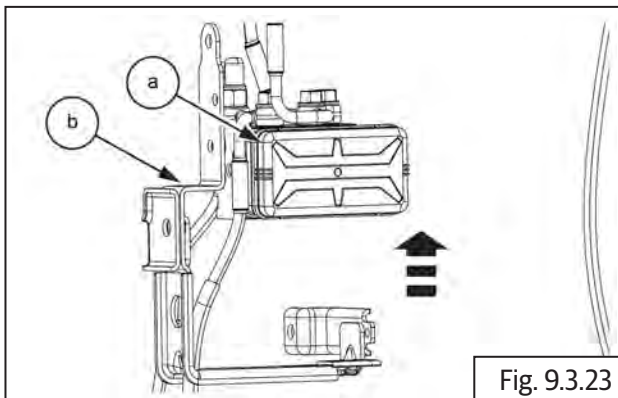

Fig. 9.3.23

- Connect ABS modulator electrical connector **(a)** into engine control unit (ECU) **(b)**.

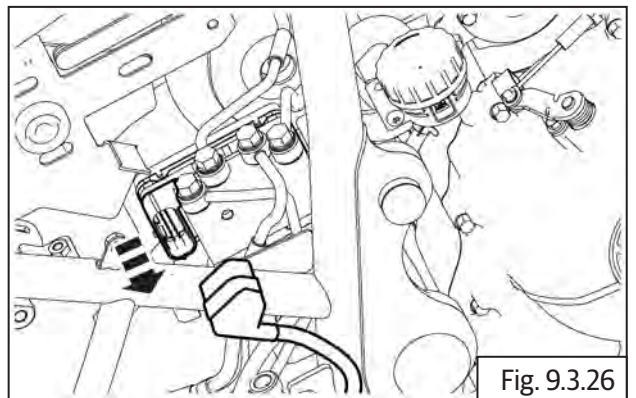

Fig. 9.3.26

- Locate and tighten hex bolt **(M6)** **(a)** at the both sides of bracket **(b)**.

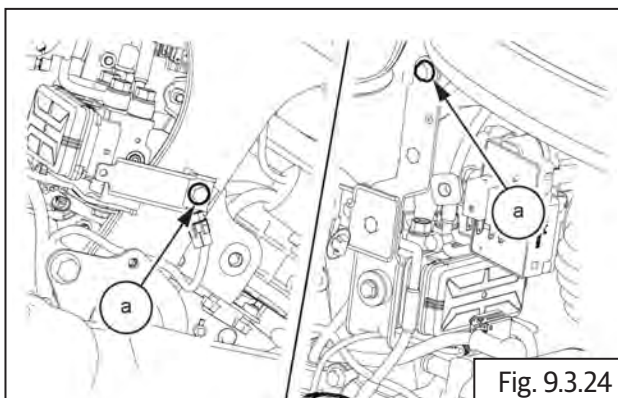

Fig. 9.3.24

- Locate brake hose mounting clamp rear **(a)** into RH side.

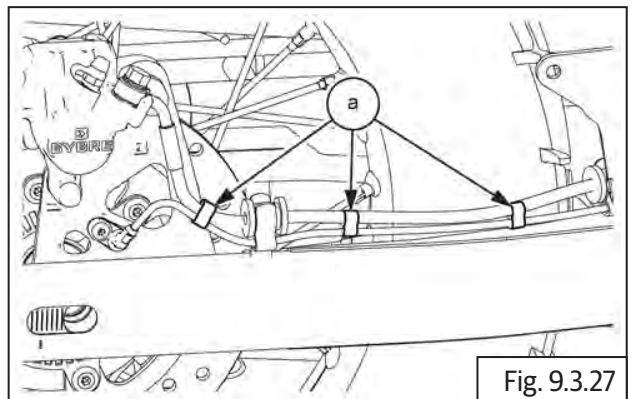
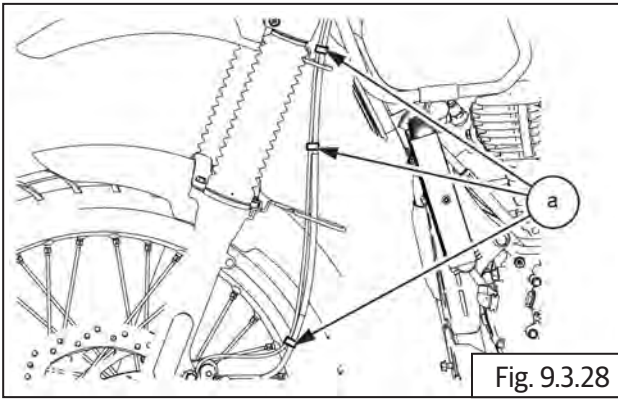

Fig. 9.3.27



10 mm Socket with Ratchet

- Locate brake hose mounting clamps front **(a)** into frame.



- Locate and assemble banjo bolt **(a)** along with washers **(b)** and connect hose **(c)** into rear master cylinder assembly.

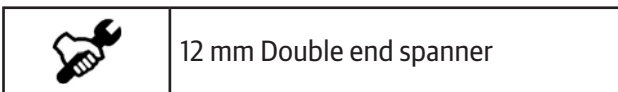
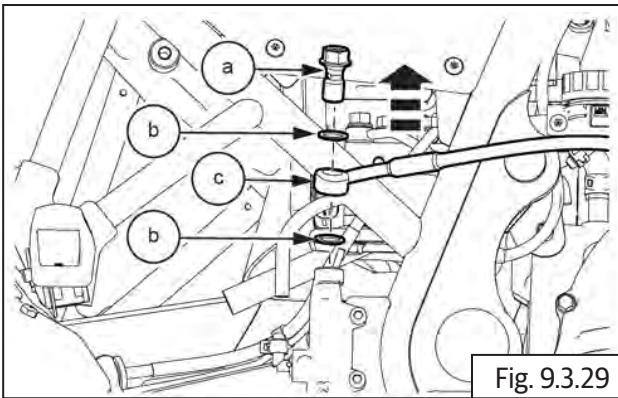

- Locate and assemble banjo bolt **(a)** and connect hose **(b)** into rear caliper from rear wheel RH.

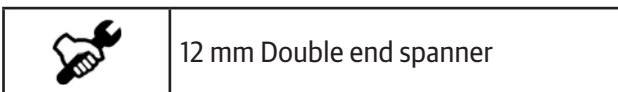
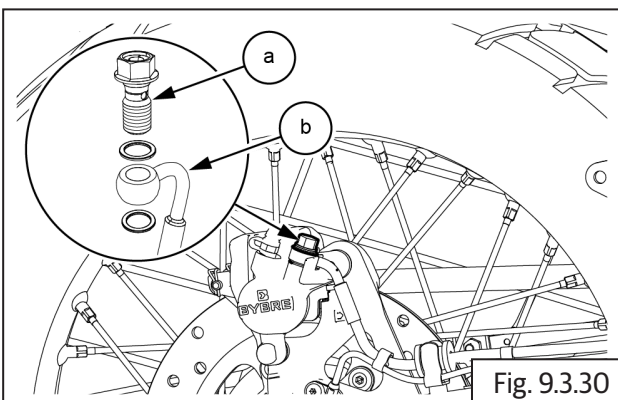

- Locate and assemble banjo bolt **(a)** and connect hose **(b)** into front master cylinder on handlebar RH.

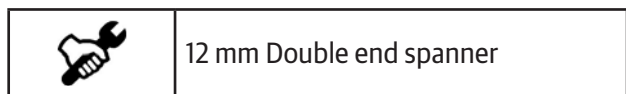
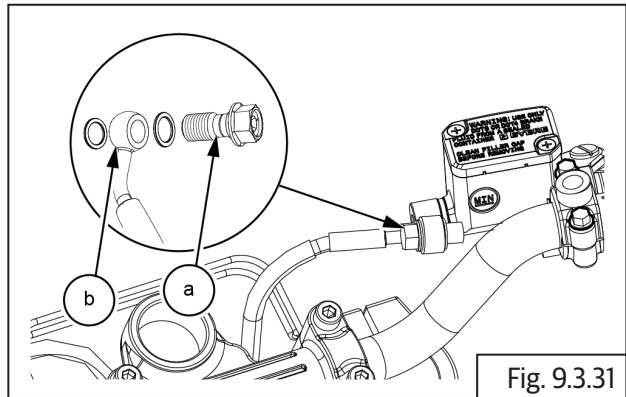

- Locate and assemble banjo bolt **(a)** and connect hose **(b)** into front caliper on front fork LH.

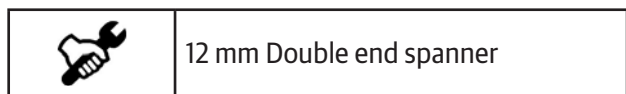
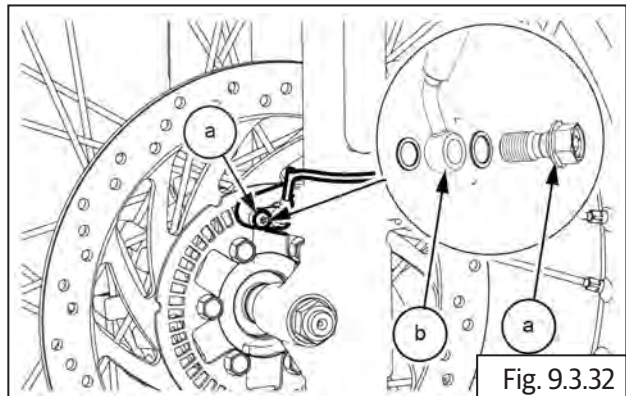

- **Assemble the following parts:**
 - Fuel tank assembly ([section 7.1.15](#)).
 - Rider seat ([section 6.7.7](#)).
 - Side panel RH ([section 6.7.8](#)).

⚠ CAUTION

After assembly of all aggregates, ensure the following:

- **Fuel is refilled/top up into fuel tank.**
- **Fuel feed and return hoses are properly connected into the fuel rail.**
- **Wiring couplers to fuel pump and low fuel sensors are properly connected.**
- **EVAP hose pipes are properly connected.**

⚠ WARNING

Gasoline is extremely flammable and highly explosive. Improper handling can lead to fatal accident or serious injury.

9.3.11 ABS DTC Codes

DTC (P code)	Failure type	Failure Description	Query	Remedy
C1021	ECU	ABS ECU Internal fault	ABS Microcontroller Failure	Change ABS unit
C1019	VR	ABS ECU Relay Fault	Failure in the ABS valve relay	Change ABS unit
C1054	Valves EV	(EV) ABS Apply Solenoid Circuit Open or high Resistance (Front)	Failure in the front Inlet Valve	Change ABS unit
C1052		(EV) ABS Apply Solenoid Circuit Open or high Resistance (Rear)	Failure in the rear Inlet Valve	Change ABS unit
C1049		(AV) ABS Release Solenoid Circuit Open or high Resistance (Front)	Failure in the front Outlet Valve	Change ABS unit
C1048		(AV) ABS Release Solenoid Circuit Open or high Resistance (Rear)	Failure in the rear Outlet Valve	Change ABS unit
C1059	UZ	ABS Voltage High	Battery Voltage Too high	Check the voltage regulator/Battery
C1058		ABS Voltage Low	Battery Voltage Too Low	Check the Battery
C1015	RFP/RFP_HW	ABS Pump/Motor Failure	Failure in the ABS Pump Motor	Change ABS unit
C1033	WSS_ohmic	ABS Wheel Speed Circuit Open or Shorted (Front)	Failure in the Front WSS (electric)	Change Front WSS or Check wiring from WSS to ABS"
C1031		ABS Wheel Speed Circuit Open or Shorted (Rear)	Failure in the Rear WSS (electric)	Change Rear WSS or Check wiring from WSS to ABS
C1034	WSS_plausibility	ABS Wheel Speed Intermittent (Front)	Signal quality from the front WSS is not good	Check the front toner wheel/ Airgap consistency/WSS bracket
C1032		ABS Wheel Speed Intermittent (Rear)	Signal quality from the Rear WSS is not good	Check the Rear toner wheel/ Airgap consistency/WSS bracket

DTC (P code)	Failure type	Failure Description	Query	Remedy
C1024	WSS_ GENERIC	(GENERIC) ABS Wheel Speed Difference too high	Signal quality from the front/ Rear WSS is not good	Check the front toner wheel/ Airgap consistency/WSS bracket
U2922	CAN_ BUSOFF	High Speed CAN Communications Bus Fault	CAN BusOff failure	Check for CAN lines connection
U2921	CAN_ GENERIC	CAN Generic monitoring	CAN controller failure. Diagnosis is not possible with tester in this case.	Change ABS unit

Bleeding the Hydraulic Brake System With DOL Tool (Front & Rear)

9.4. Preparation (Front Disc Brake)

- Use a Philips screwdriver to loosen and remove the screws of the front disc brake master cylinder.
- Remove the cap, and Diaphragm Plate with diaphragm.
- Remove the dust cap and place the suitable ring spanner on the bleeding nipple and attach a Vinyl Pipe (transparent).
- Thereafter, take a Clean glass / Plastic container (transparent) with fresh brake fluid, and dip the other end of the vinyl pipe (transparent) in it (make sure that the vinyl pipe is always submerged in the fluid during the bleeding process).

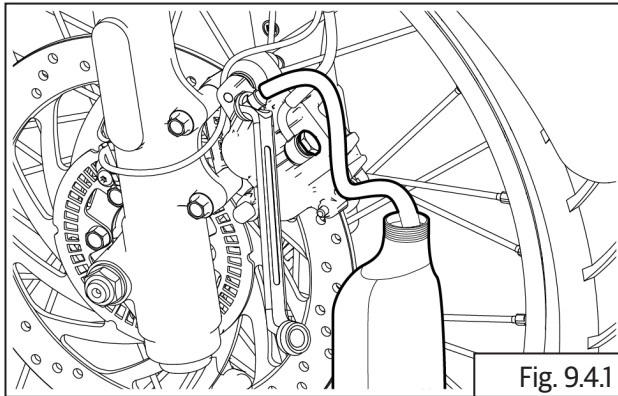

- Connect the DOL tool switch "ON" the ignition.

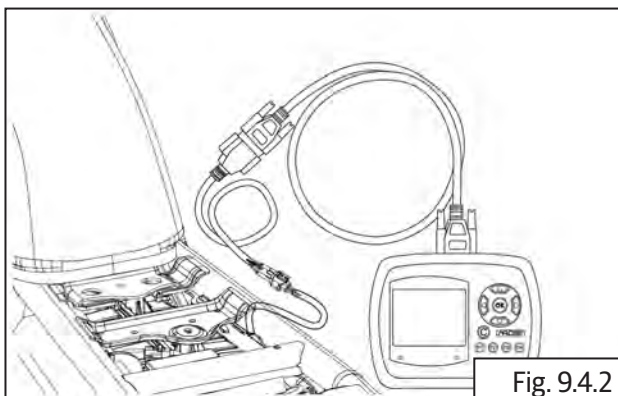

Procedure

- Select - F1 Diagnosis.

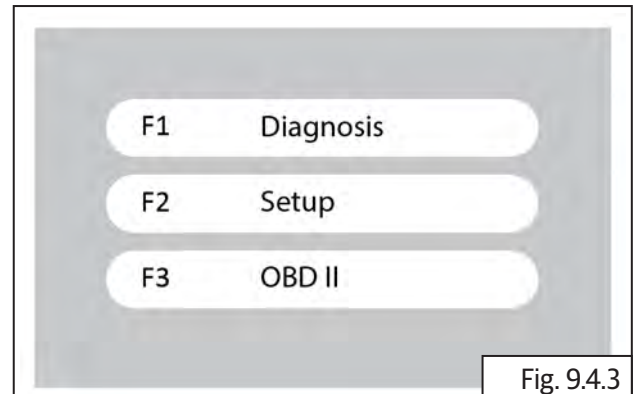

- Select - Royal D1.

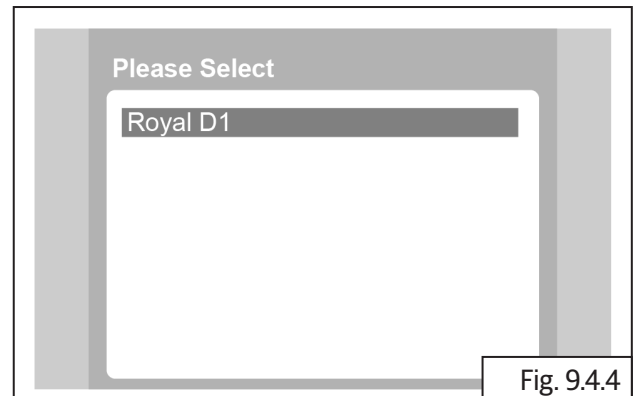

- Select - Bosch ABS.

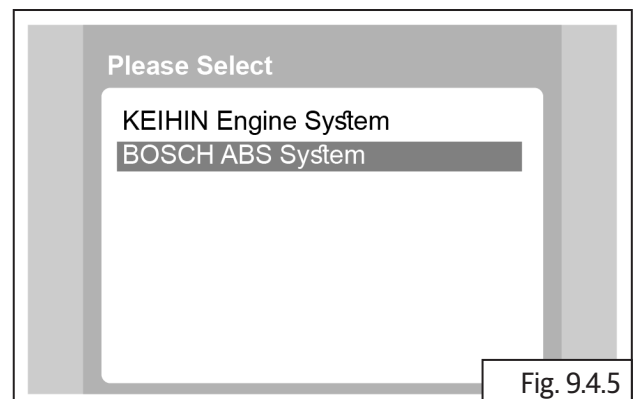

- Default Screen.

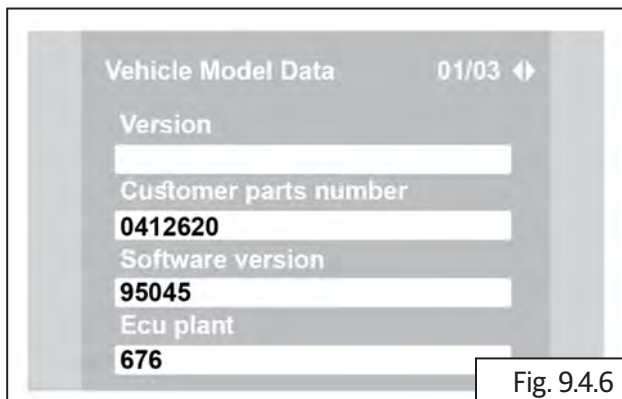

Fig. 9.4.6

- Press C.



Fig. 9.4.7

- Select - Spl Function.

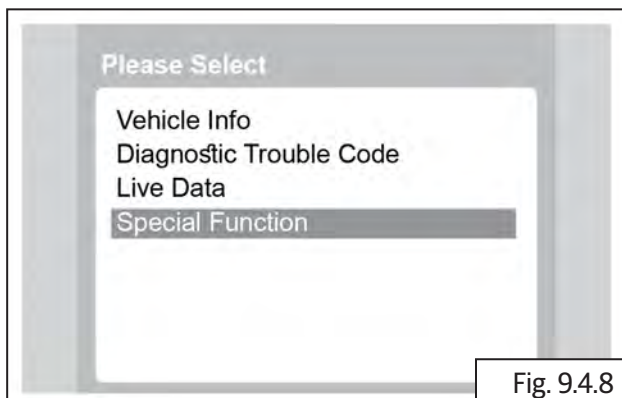

Fig. 9.4.8

- Select - Repair Air Bleed.

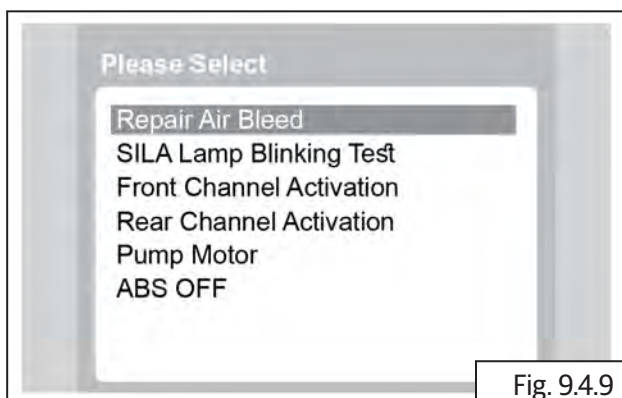

Fig. 9.4.9

- Default Screen.

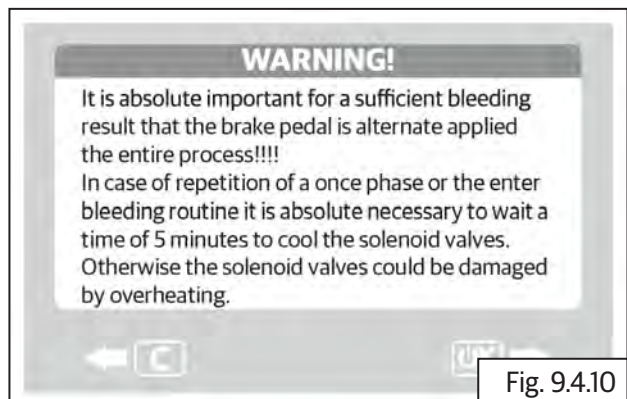

Fig. 9.4.10

- Default Screen.

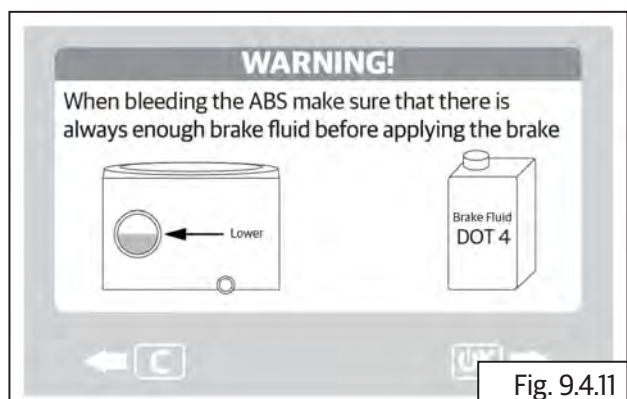

Fig. 9.4.11

- Loosen the bleeder nipple.

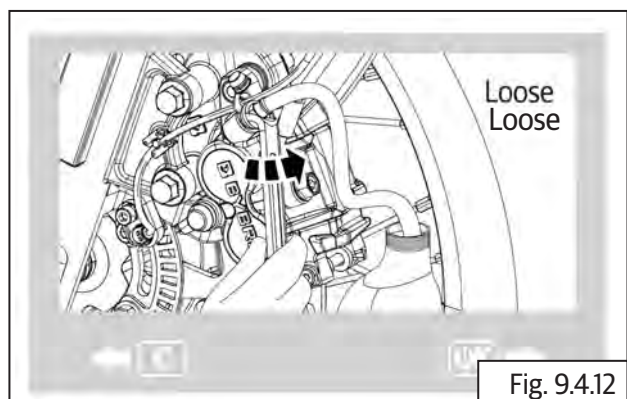

Fig. 9.4.12

- Operate the brake lever.

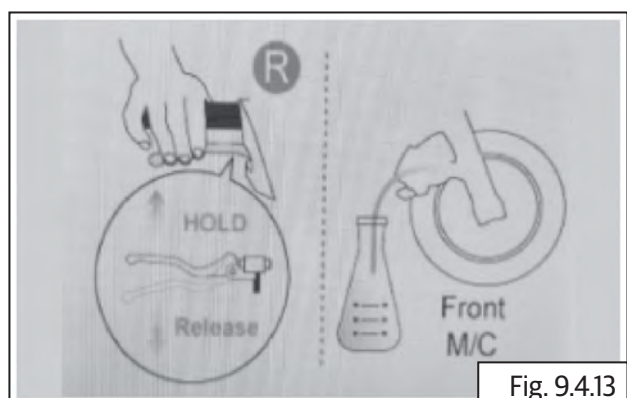

Fig. 9.4.13

- Hold the lever in pressed condition and tighten the bleeder nipple.

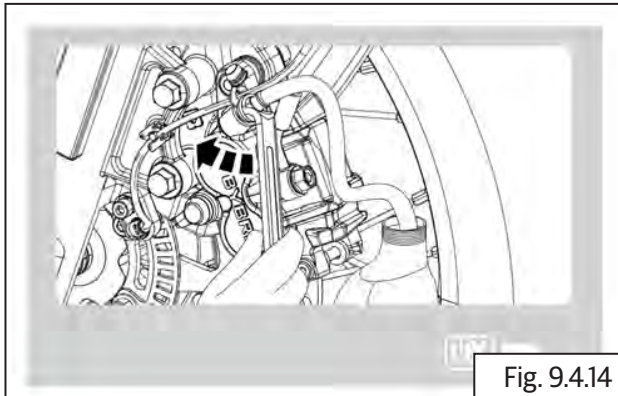

Fig. 9.4.14

- Hold the brake lever in pressed condition and tighten the bleeding nipple.

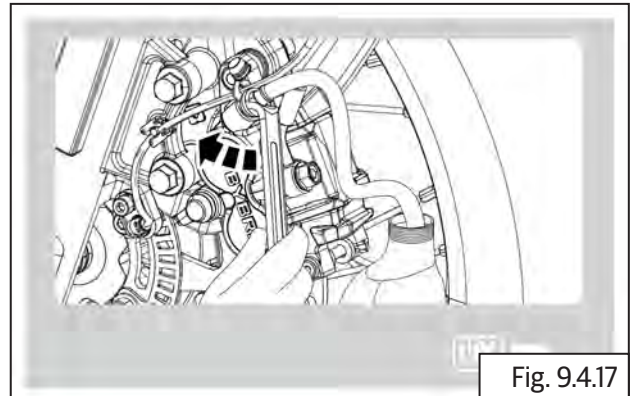

Fig. 9.4.17

- Loosen the bleeder nipple - (Brake lever in released condition).

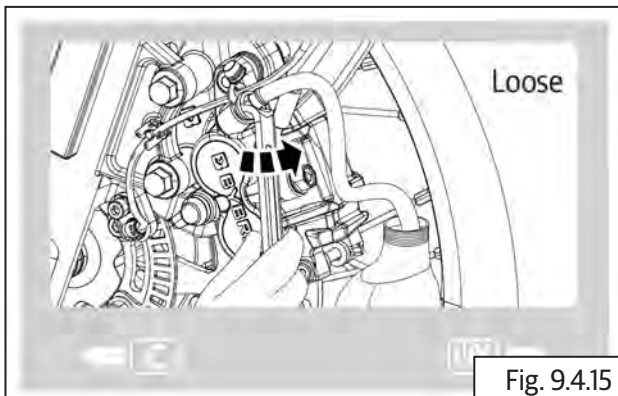

Fig. 9.4.15

- Operate the brake lever till the next window open in DOL.

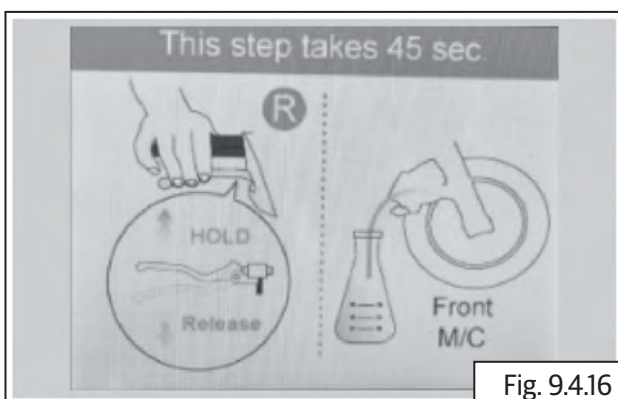

Fig. 9.4.16

- During this operation pump will run and expel the air trapped in the system through bleeder nipple.

9.5. Reassembly

- Switch OFF the ignition.
- Disconnect the DOL Tool.
- Remove the vinyl pipe and remove the ring spanner.
- Refit the dust cap (make sure that there is no leak from the bleeder nipple).
- Refit the diaphragm with diaphragm plate of the master cylinder.
- Refit the master cylinder cap taking care that the vent slot in the cap is facing rider.

9.6. Preparation (Rear Disc Brake)

- Remove the reservoir cap of the rear disc brake.
- Remove the Diaphragm Plate with diaphragm.
- Remove the dust cap and place the suitable ring spanner on the bleeding nipple.
- Attach a Vinyl Pipe (transparent).
- Thereafter, take a Clean glass / Plastic container (transparent) with fresh brake fluid, and dip the other end of the vinyl pipe (transparent) in it (make sure that the vinyl pipe is always submerged in the fluid during the bleeding process).

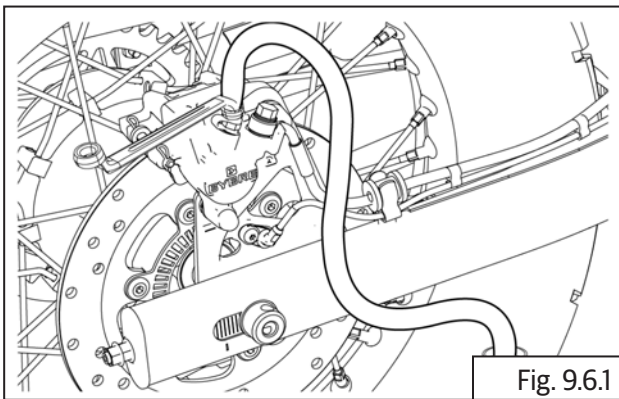

- Connect the DOL tool switch on the ignition

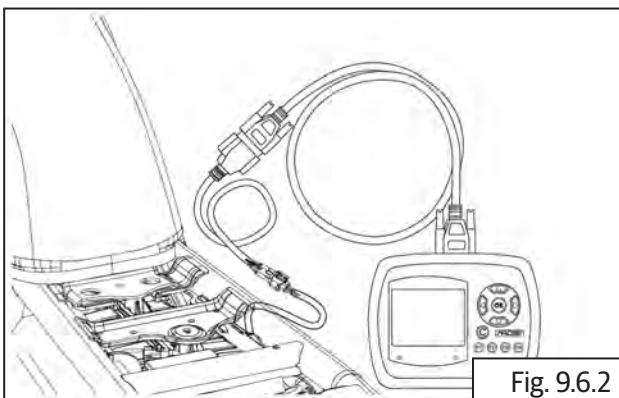

- Loosen the bleeder nipple.

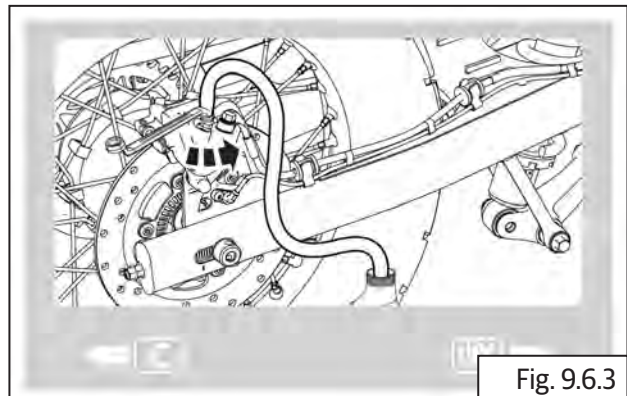

- Default Screen.

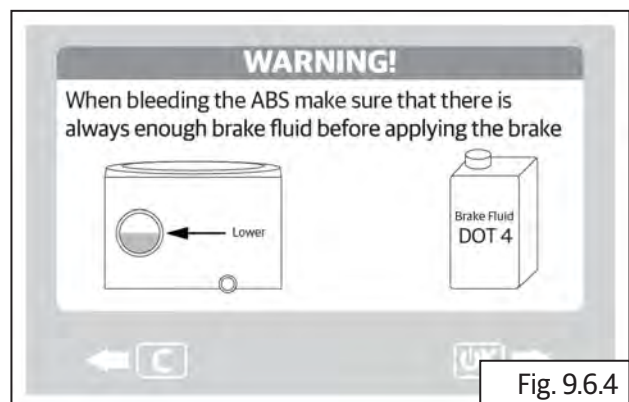

- Operate the brake lever.

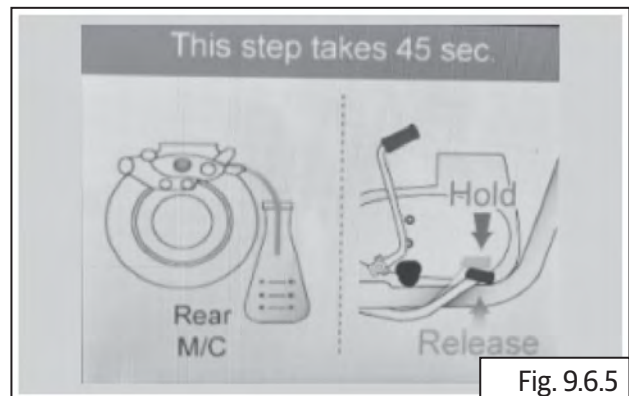

- Hold the brake Pedal in pressed condition and tighten the bleeding nipple.

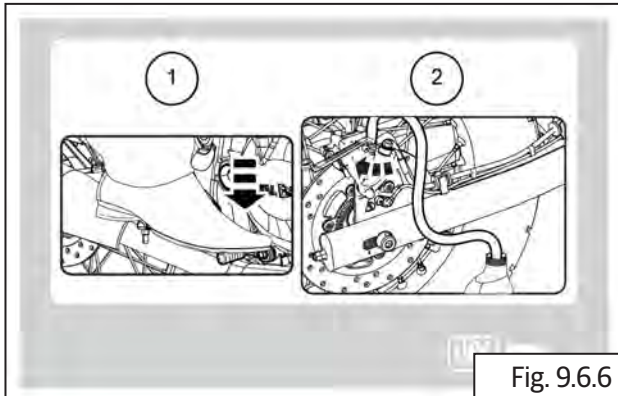

Fig. 9.6.6

- Hold the brake lever in pressed condition and tighten the bleeding nipple.

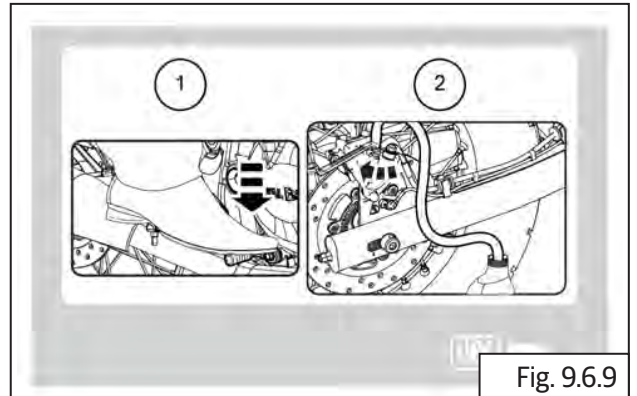

Fig. 9.6.9

- Loosen the bleeder nipple - (Brake lever in released condition)

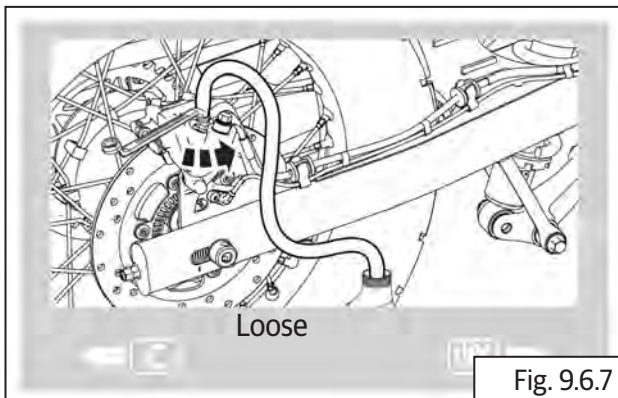

Fig. 9.6.7

- During this operation pump will run and expel the air trapped in the system through bleeder nipple

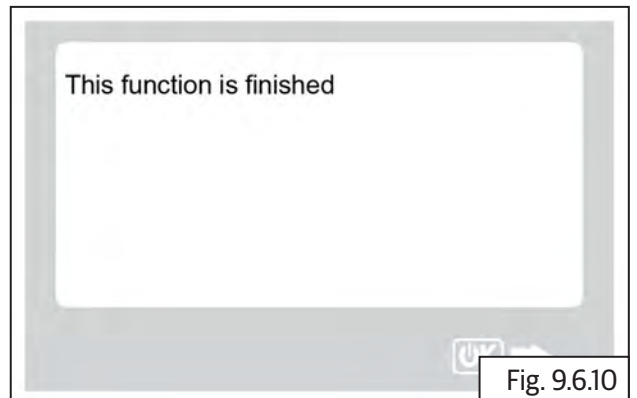

Fig. 9.6.10

- Operate the brake lever until the next window opens in DOL.

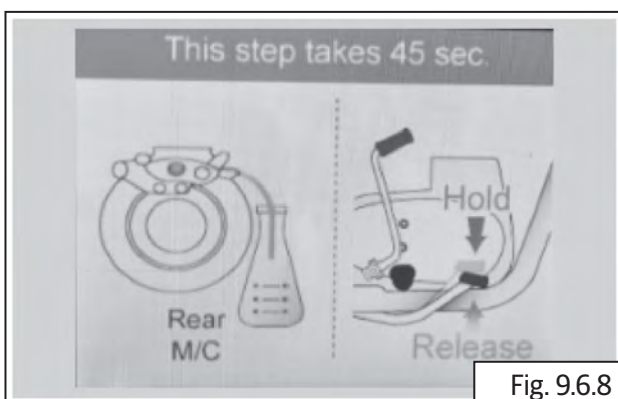

Fig. 9.6.8

9.7. Reassembly

- Switch OFF the ignition and disconnect and remove the DOL tool.
- Remove the vinyl pipe and remove the ring spanner.
- Refit the dust cap (make sure that there is no leak from the bleeder nipple).
- Refit the diaphragm with diaphragm plate of the reservoir.
- Refit the reservoir cap.

BRAKE BLEEDING (Front & Rear)

Manual Method

9.8. Brake Bleeding

⚠ CAUTION

Ensure the motorcycle is upright on a firm and flat surface.

Support motorcycle with suitable equipment below cradle frame.

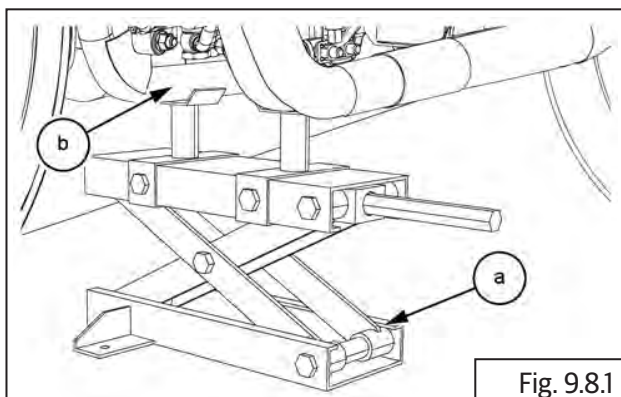

⚠ CAUTION

Do not spill brake fluid on any part of the motorcycle as it will damage the painted/plastic surfaces.

⚠ WARNING

Ensure brake fluid does not get in contact with eyes and skin. In-case of exposure wash affected area thoroughly with water. Seek medical attention immediately if any irritation persists.

Keep out of reach of children.

Dispose drained brake fluid carefully and responsibly.

⚠ WARNING

Brake fluid is Hygroscopic hence, absorbs moisture from air. Ensure fluid reservoirs caps are closed properly.

If moisture in the brake system may cause damage to brake parts and fluid, causing reduction in braking efficiency; which in turn may lead to fatal accidents.

NOTE

- Use brake fluid from sealed containers only.
- Use only DOT4 specification brake fluid listed in technical specifications ([section 2.4](#)).
- Ensure ignition switch and stop switch are in ON position.

9.8.1. Front Brake Bleeding

- Loosen and remove 2 Nos. screws (a) from front brake reservoir tank.

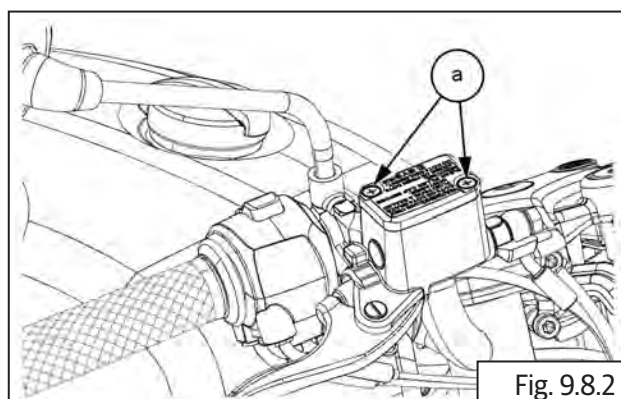

Screw driver phillips

- Remove reservoir cap (a) from front brake reservoir tank (b).

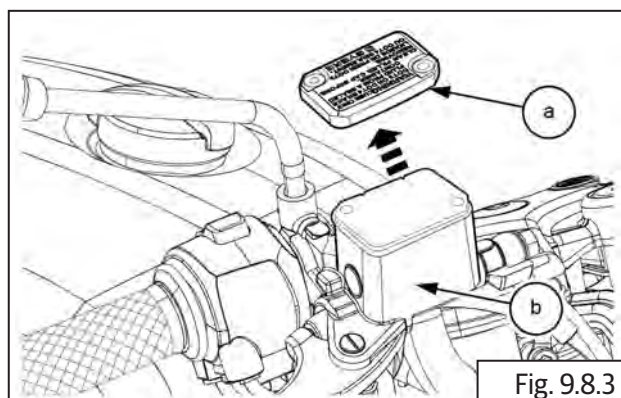

- Remove reservoir diaphragm **(a)** from front brake reservoir tank **(b)**.

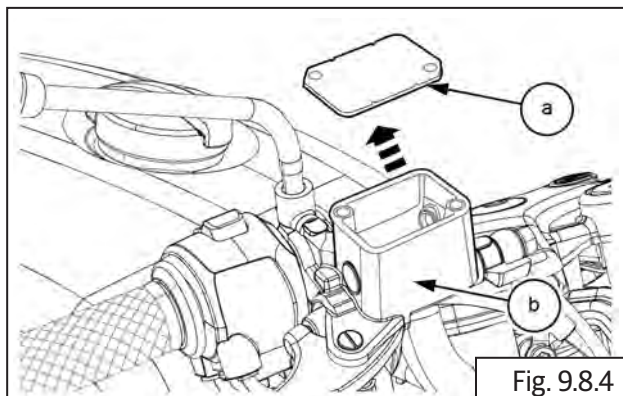

Fig. 9.8.4

- Remove rubber cap **(a)** from bleeder valve **(b)** from front caliper on front wheel RH.

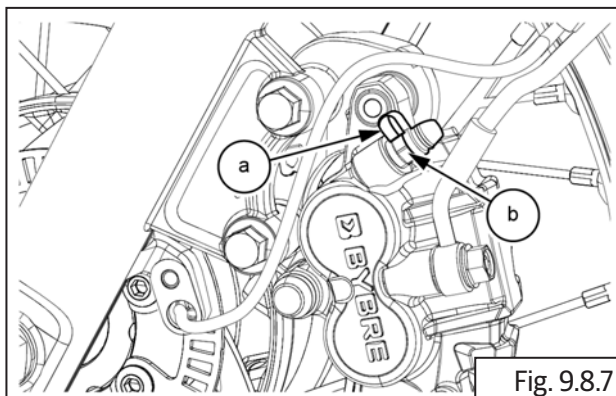

Fig. 9.8.7

- Gently top up fresh brake fluid **(a)** into reservoir **(b)**.
- Do not over fill as it may cause malfunctioning of some parts due to brake fluid spillage.

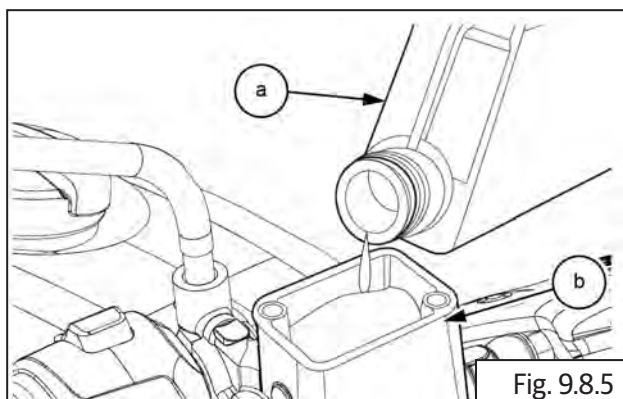

Fig. 9.8.5

- Dip bleeder hose **(a)** one end into a container **(b)** with fresh brake fluid to avoid air passage into bleeder valve.
- Insert bleeder hose other end into bleeder valve **(c)** on front caliper to drain used oil.

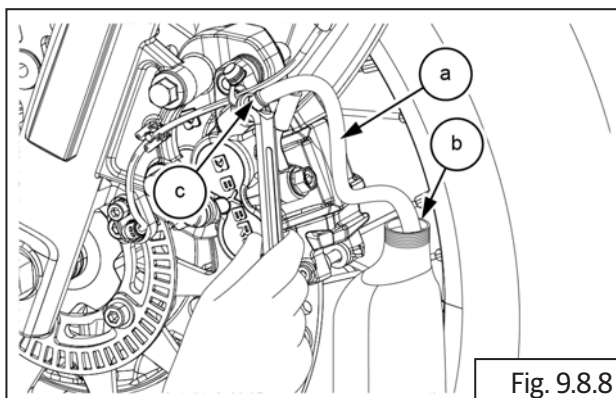

Fig. 9.8.8

- Locate diaphragm and cap **(a)** on the reservoir and DO NOT fasten with screws.

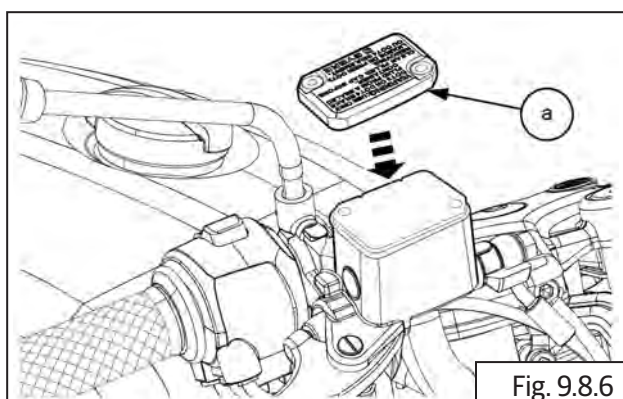

Fig. 9.8.6

NOTE

- Use brake fluid from new, sealed containers only.
- Use only DOT4 specification brake fluid listed in technical specifications ([section 2.4](#)).

- Gently pump brake lever **(a)** until brake is effective.
- Once brake lever is effective, hold it in place.

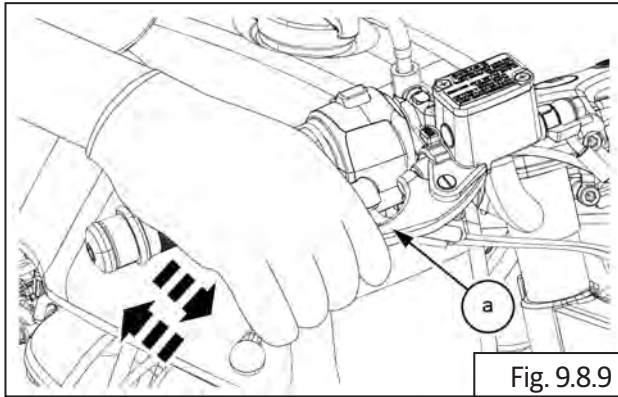

Fig. 9.8.9

- While holding brake lever, quickly open and close bleeder valve **(M6) (a)**.

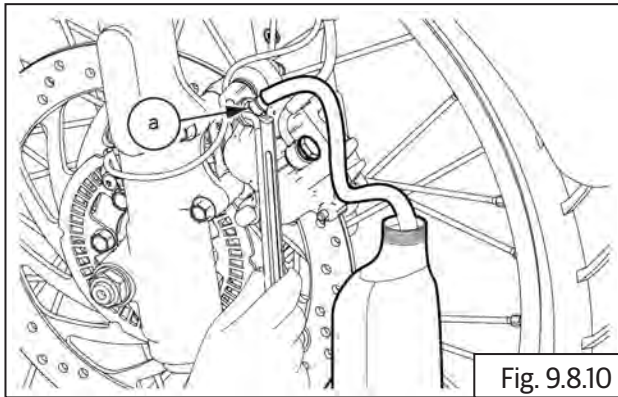

Fig. 9.8.10



11 mm Ring spanner and air bleeder.

- Release the brake lever **(a)**.

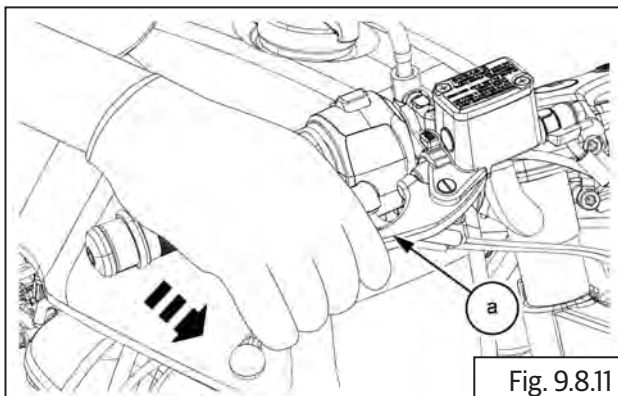

Fig. 9.8.11

- Gently top up fresh brake fluid **(a)** into reservoir **(b)**.
- Do not over fill as it may cause malfunctioning of some parts due to brake fluid spillage.

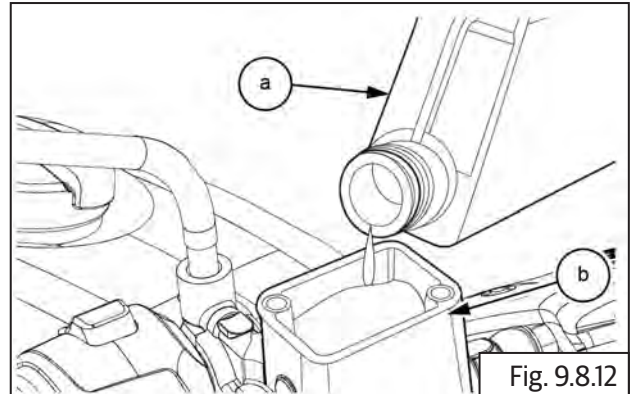

Fig. 9.8.12

- Repeat this operation until air from the system is released completely. Observe bleeder hose. As air in the system is cleared, bubbles stop appearing in hose.

⚠ CAUTION

While bleeding the brake system always ensure brake fluid is above min level BUT below "Max" level. Never allow the brake fluid go below minimum level to avoid air entering brake system. Always fill the brake fluid from sealed container only.

Do not leave the master cylinder cap and or brake fluid container open for long as brake fluid is highly hygroscopic in nature and will lose its properties if exposed to atmospheric conditions.

- Inspect brake lever efficiency.

NOTE

- *The fluid level must be checked often during the bleeding operation and top up with fresh brake fluid as necessary.*
- *Gently tap brake hose for proper bleeding performance.*
- *Check brake fluid level after completion of brake bleeding.*
- *Whenever the modulator is removed or replaced the brake bleeding time will be longer as brake fluid will have to travel from master cylinder to modulator and then to wheel caliper*
- *Whenever bleeding the brake system, it is always recommended to bleed both the front and rear brakes.*

- Remove bleeder hose **(a)** from bleeder valve **(b)**.

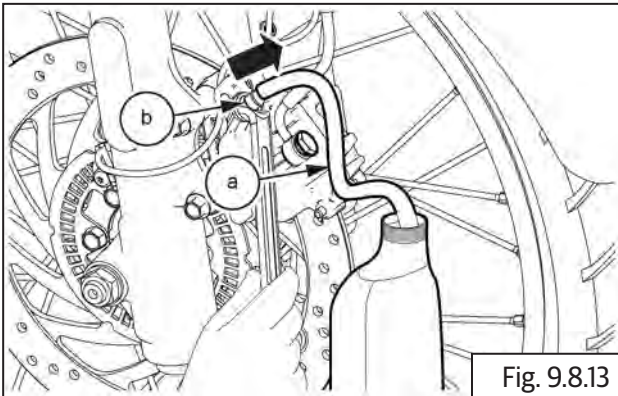

- Close rubber cap **(a)** on bleeder valve **(b)**.
- Ensure cap is locked properly to avoid exposure to dust or mud.

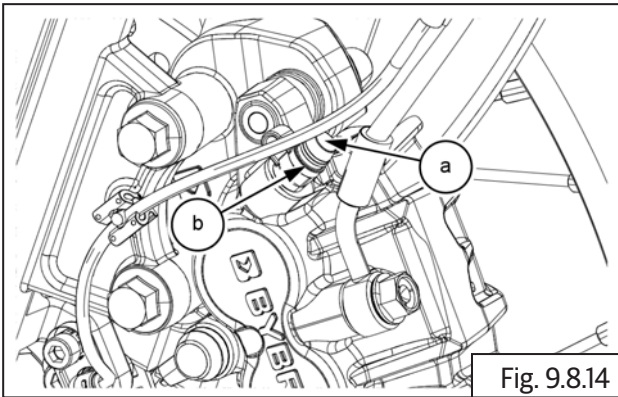

- Install reservoir diaphragm **(a)** into front brake reservoir tank **(b)**.

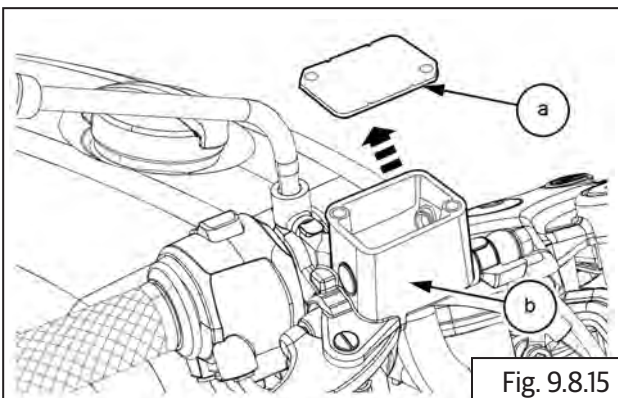

- Locate and tighten 2 Nos. screws **(a)** into front brake reservoir tank **(b)**.

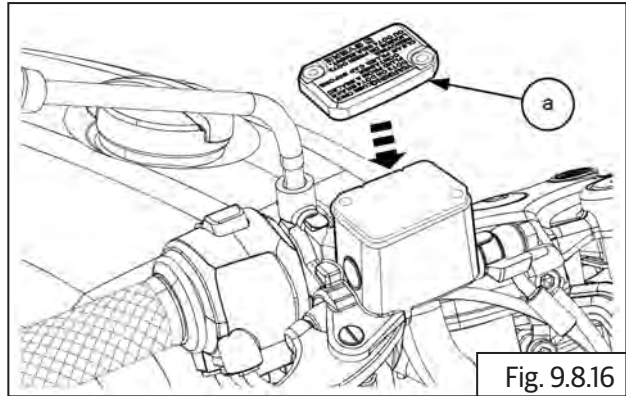

Screw driver

9.8.2. Front Brake Fluid Leakage

⚠ CAUTION

Ensure motorcycle is placed on a flat surface resting it on ramp/center stand.

NOTE

- Inspect fluid level at every 5000 Km (300 miles). Replace fluid after 25000 Km (1500 miles).

- Inspect fluid level, visible in window glass on front reservoir tank **(a)**.
- Ensure brake fluid level is always above 'MIN' mark **(b)** on window.

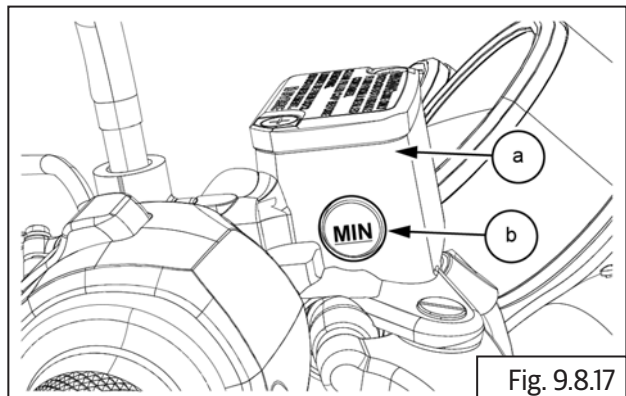

- If oil level is below 'MIN', inspect leakage at front brake hoses and front master cylinder banjo bolt.

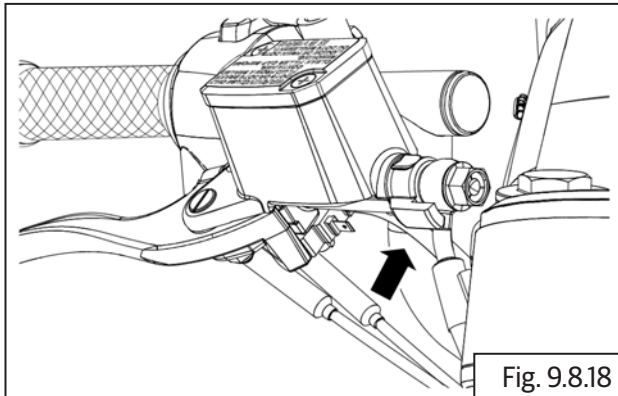

- Inspect leakage at caliper banjo bolt.

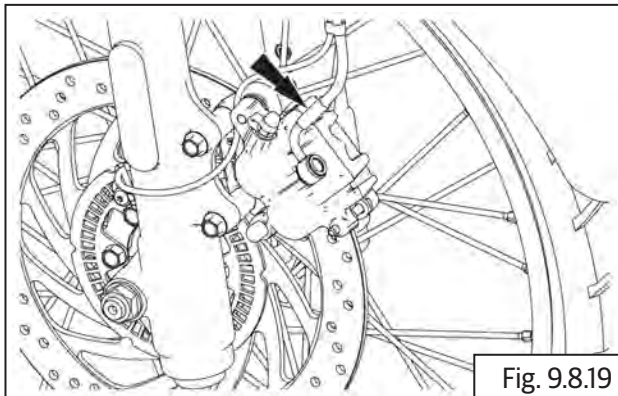

- Inspect leakage on brake disc from caliper piston.

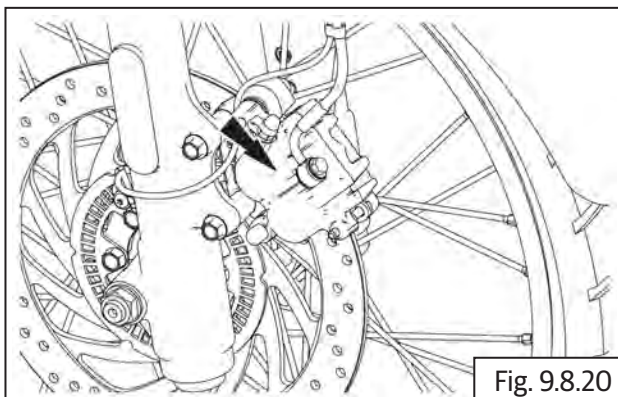

- Inspect fluid leakage at hoses at ABS modulator.

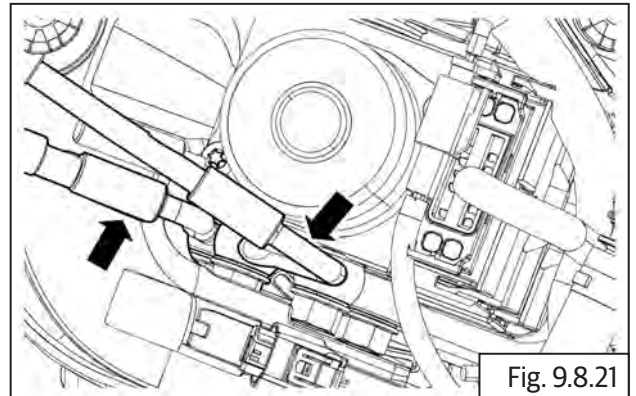

9.8.3. Front Brake Fluid Top up

- Loosen and remove 2 Nos. screws (a) from front brake reservoir tank.

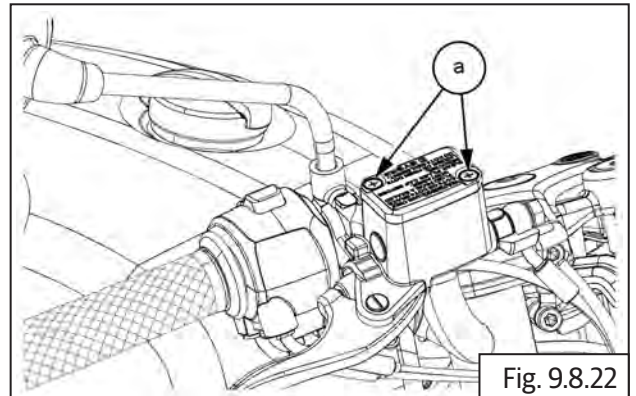

Screw driver

- Remove reservoir cap (a) from front brake reservoir tank (b).

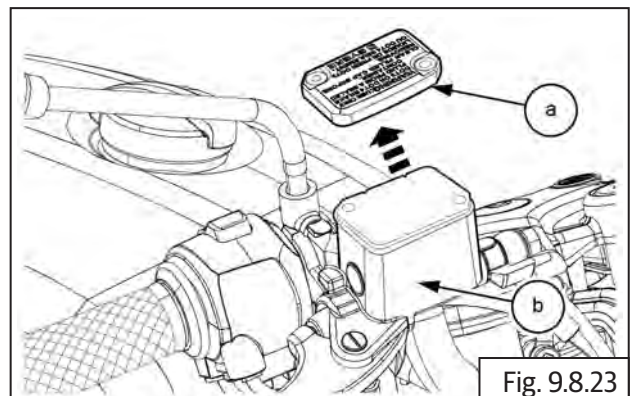

- Remove reservoir diaphragm **(a)** from front brake reservoir tank **(b)**.

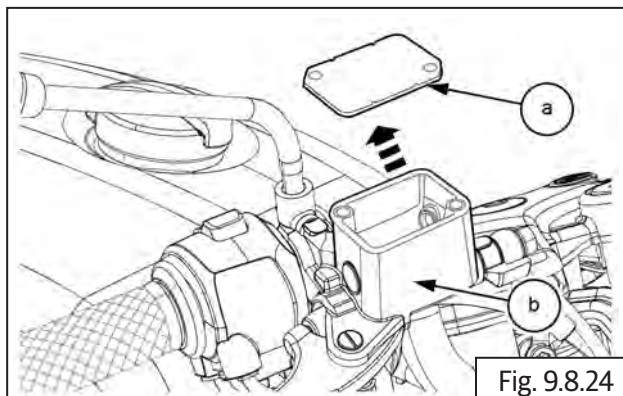

Fig. 9.8.24

- Top up fresh fluid **(a)** into reservoir tank **(b)** up to 'MAX' mark on the window.
- Do not over fill as it may cause malfunctioning of some parts due to brake fluid spillage.

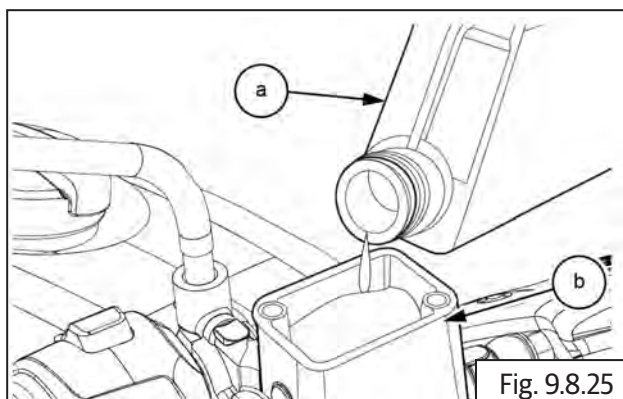

Fig. 9.8.25

9.8.4. Rear Brake Bleeding

⚠ CAUTION

Ensure the motorcycle is upright on a firm and flat surface.

Support motorcycle with suitable equipment below cradle frame.

- Rear brake reservoir is located near rear wheel on cradle frame.
- Open rear brake reservoir cap **(a)** from reservoir **(b)**.

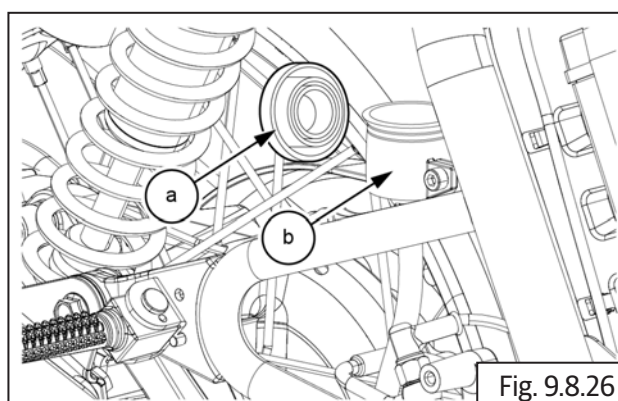

Fig. 9.8.26

NOTE

- Use brake fluid from sealed containers only.
- Use only DOT4 specification brake fluid listed in technical specification Information ([section 2.4](#)).

- Fill fresh brake fluid **(a)** into reservoir **(b)**.

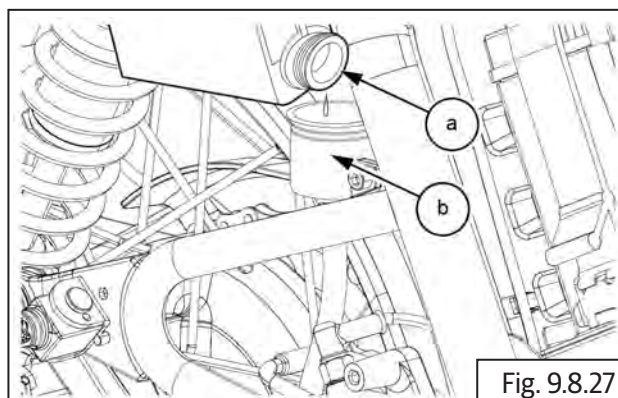
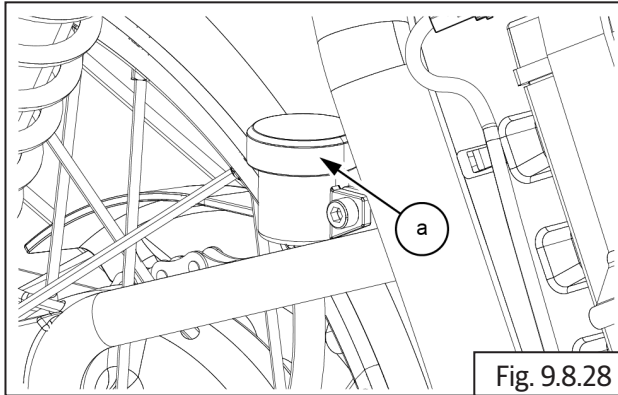
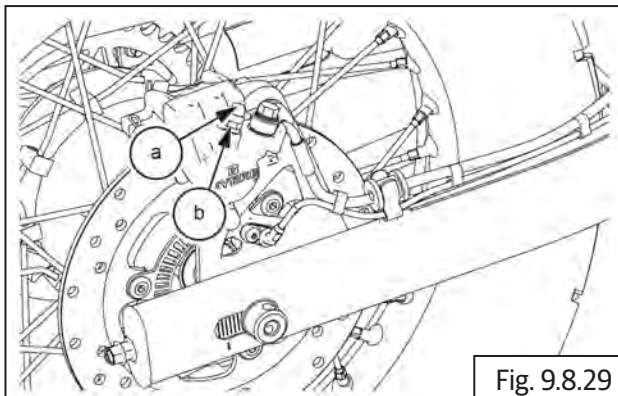

Fig. 9.8.27

- Do not over fill as it may cause malfunctioning of some parts due to brake fluid spillage.
- Locate the reservoir cap **(a)** on the tank and ensure it is seated properly.



- Locate rear brake bleeder valve on rear wheel brake caliper, behind silencer.
- Open rubber cap **(a)** from rear brake bleeder valve **(b)**.



- Dip bleeder hose **(a)** one end into a container **(b)** with fresh brake fluid to avoid air passage into bleeder valve.
- Insert bleeder hose other end into bleeder valve **(M6) (c)** on front caliper to drain used oil.

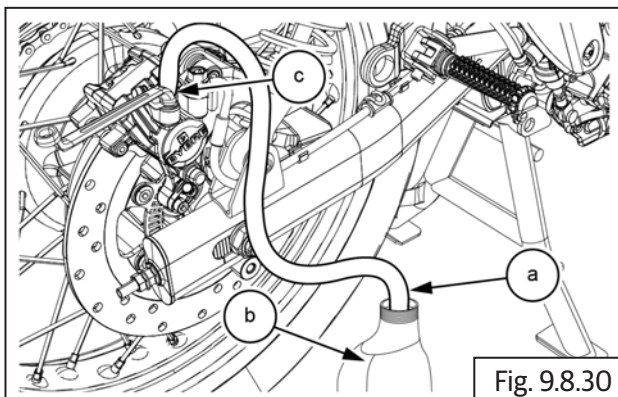

11 mm Ring spanner

- Gently pump rear brake pedal **(a)** until pumping becomes hard and then hold it in place.

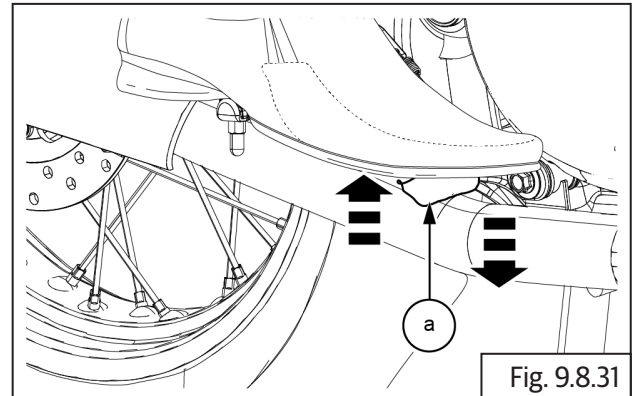

- While holding brake, quickly open and close bleeder valve **(M6) (a)**.

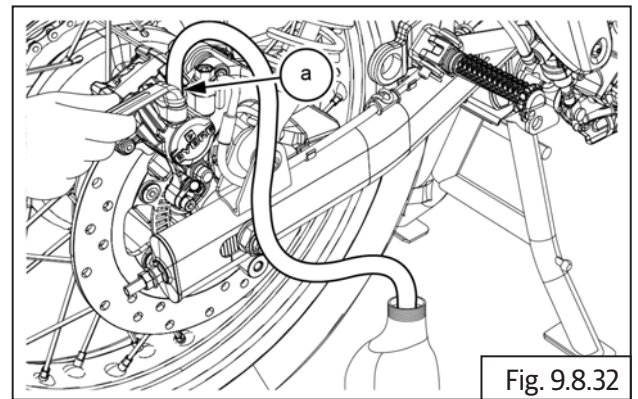

- Repeat this operation until air from system is released completely.
- Inspect brake lever efficiency.

NOTE

- *The fluid level must be checked often during the bleeding operation and top up with fresh brake fluid as necessary.*
- *Gently tap brake hose for proper bleeding performance.*
- *Check brake fluid level after completion of brake bleeding.*

- Remove bleeder hose **(a)** from bleeder valve on rear caliper.

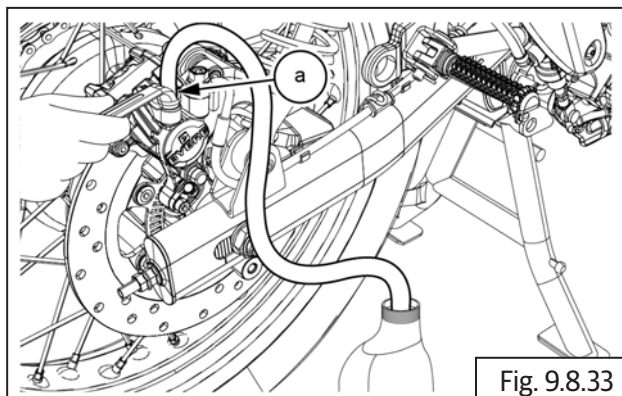

Fig. 9.8.33

- Close bleeder valve **(a)** rubber cap **(b)**.
- Ensure cap is locked properly to avoid exposure to dust or mud.

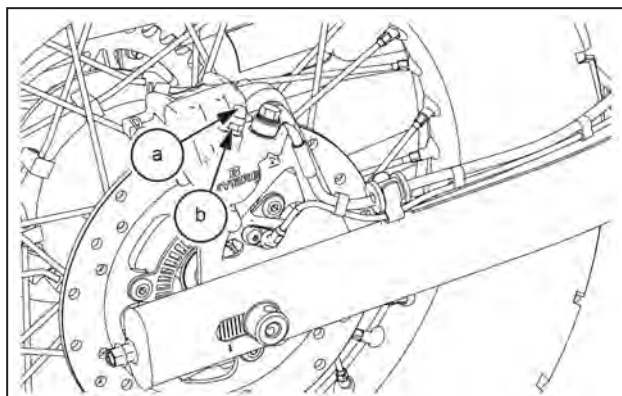

Fig. 9.8.34

9.8.5. Rear Brake Fluid Leakage

⚠ CAUTION

Ensure the motorcycle is upright on a firm and flat surface.

NOTE

- Inspect fluid level at every 5000Km (3000 miles). Replace fluid after 25000Km (15000 miles).

- Inspect fluid level visible on rear reservoir tank.
- Ensure brake fluid level in rear reservoir tank is always between 'MIN' and 'Max' marks.

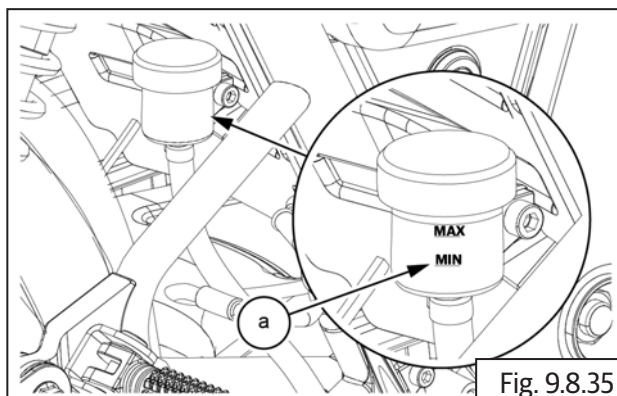

Fig. 9.8.35

- If oil level is below 'MIN', inspect leakage at rear brake hoses and rear master cylinder banjo bolt.

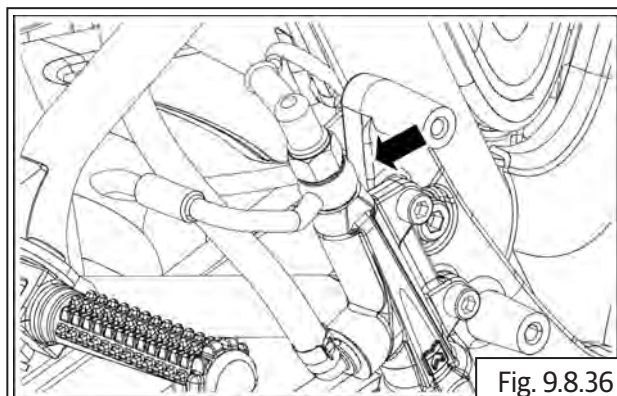

Fig. 9.8.36

- Inspect leakage at rear caliper banjo bolt.

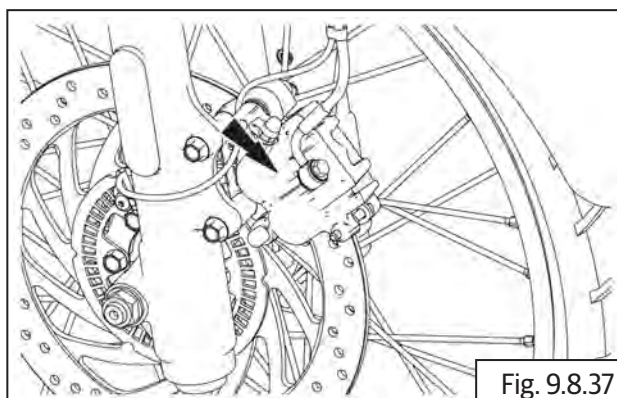

Fig. 9.8.37

- Inspect leakage on brake disc from caliper piston.

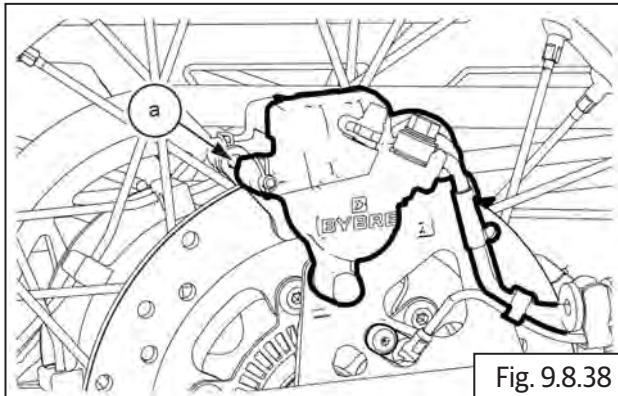

Fig. 9.8.38

- Inspect fluid leakage at hoses on ABS modulator.

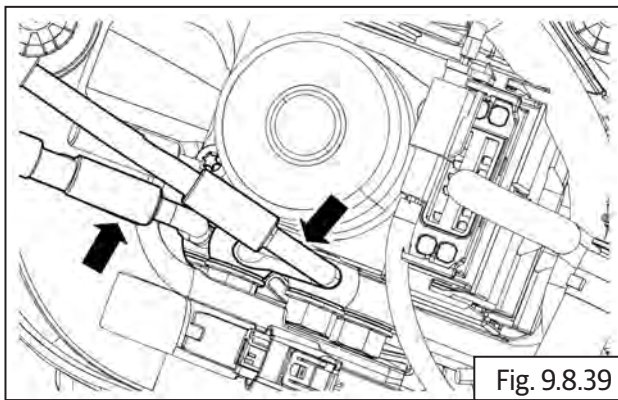

Fig. 9.8.39

9.8.6. Rear Brake Fluid Top Up

- Open rear brake reservoir cap **(a)** from reservoir **(b)**.

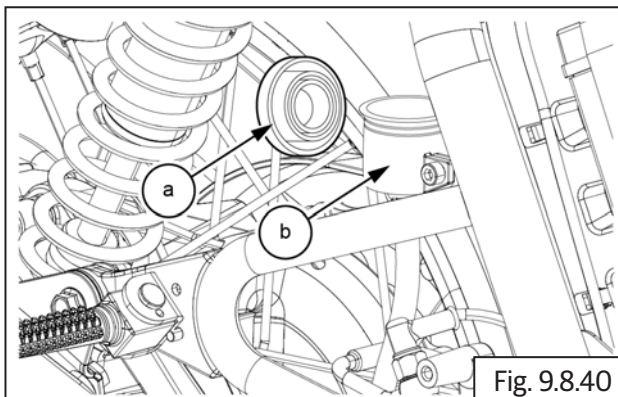

Fig. 9.8.40

- Top up fresh brake fluid **(a)** into reservoir tank **(b)** only up to MAX level. Do not over fill as it may cause malfunctioning of some parts due to brake fluid spillage.

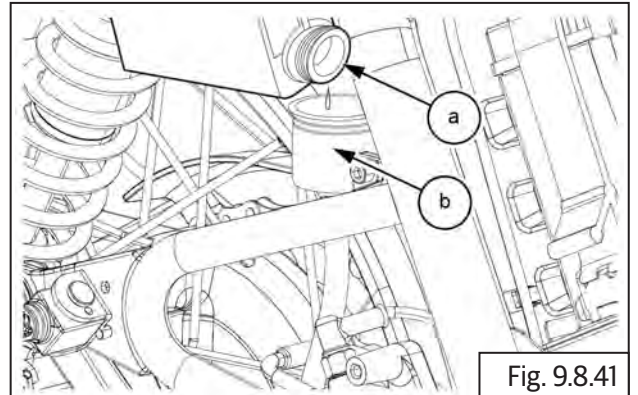

Fig. 9.8.41

- Locate the reservoir cap **(a)** on the tank and ensure it is seated properly.

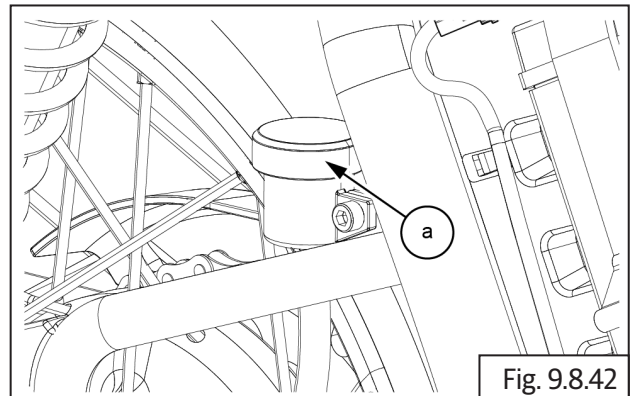

Fig. 9.8.42

ENGINE MANAGEMENT SYSTEM (EMS)

Engine Management System

CONTENTS	PAGE
Engine Management System (EMS)	365
EMS Components	365
Functional Specifications	366
1. Electronic Control Unit (ECU) Integrated with Throttle Body.....	366
Functional Diagram	366
2. Fuel Injector.....	367
3. Fuel Supply Module	367
4. Throttle Position Sensor	367
5. Manifold Absolute Pressure Sensor (MAP)	368
6. Canister Purge Valve.....	368
7. HEGO Sensor/Oxygen Sensor (HEGO / O2)	368
8. Idle Air Control Valve (IAC)	369
9. Engine Oil Temperature Sensor (EOT)	369
10. Intake Air Temperature Sensor (IAT).....	369
11. Clutch Switch	369
12. Side Stand Switch.....	370
13. Gear Position Sensor (GPS)	370
14. Roll Over Sensor	370
15. Crank Position Sensor (CPS).....	371
16. Starter Motor Relay.....	371
10.1 Engine Management System (EMS)	373
Dismantling	373
10.1.2. Fuel Pump	373
10.1.3. Throttle Body Assembly	374
10.1.4. Fuel Injectors.....	375
10.1.5. Engine Oil Temperature Sensor (EOT)	375
10.1.6. HEGO/Oxygen (O2) Sensor	376
10.1.7. Purge Valve.....	376
10.1.8. Ignition Coil.....	377
10.1.9 Crank Position Sensor	377
10.1.10. Gear Position Sensor.....	378
10.1.11. Clutch Switch	379

CONTENTS	PAGE
10.1.12. Side Stand Switch.....	379
10.1.13. Starter Motor Solenoid	380
Assembly	380
10.1.14. Engine Control Unit (ECU).....	380
10.1.15. Fuel Pump	381
10.1.16. Fuel injectors.....	381
10.1.17. Engine Oil Temperature Sensor (EOT)	382
10.1.18. HEGO (O2) Sensor.....	382
10.1.19. Purge Valve	383
10.1.20. Ignition Coil.....	383
10.1.21. Crank Position Sensor	383
10.1.22. Gear Position Sensor	384
10.1.23. Clutch Switch	384
10.1.24. Side Stand Switch.....	385
10.1.25. Starter Motor Solenoid	385
10.1.26. Actuator.....	385

Engine Management System (EMS)

Engine Management System is responsible for controlling the amount of fuel being injected and for adjusting the ignition timing. Optimum functioning of EMS assures maximum engine power with the lowest amount of exhaust emissions and lowest fuel consumption.

EMS Components

- Electronic Control Unit (Integrated with Throttle Body)
- Fuel Injector
- Fuel Supply Module
- Throttle Position Sensor (In-built within ECU)
- Manifold Pressure Sensor (In-built within ECU)
- Canister Purge Valve
- HEGO (O₂) Sensor
- Idle Air Control Valve (In-built within ECU)
- Secondary Air Injection Solenoid
- Engine Oil Temperature Sensor
- Intake Air Temperature Sensor (In-built within ECU)
- Clutch Switch
- Side Stand Switch
- Gear Position Sensor
- Roll Over Sensor (In-built within ECU)
- Crank Position Sensor
- Starter Motor Relay

Functional Diagram

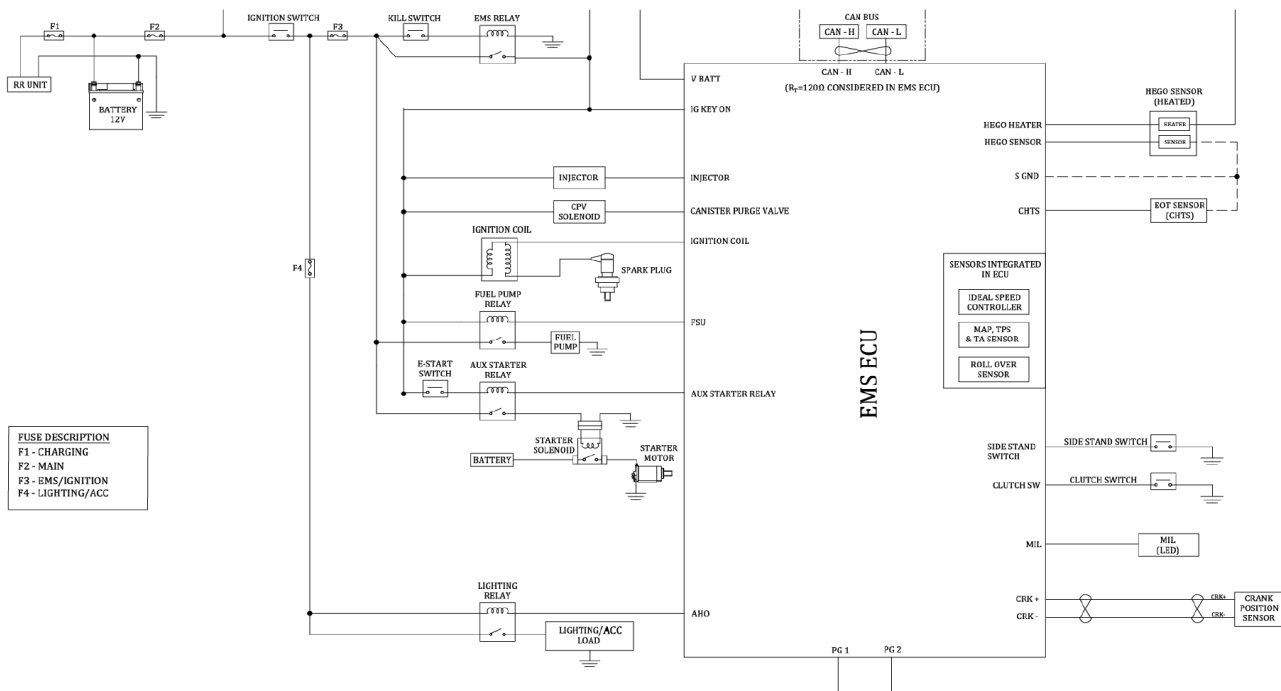

Functional Specifications

1. Electronic Control Unit (ECU) Integrated with Throttle Body

Electronic Control Unit integrated with throttle body and makes a single module. Electronic control unit is any embedded system that controls one or more electrical system or subsystems in a vehicle. Engine Control Unit is a type of Electronic

Control Unit that controls a series of actuators on an internal combustion engine to ensure optimal engine performance. It does this by reading values from a multitude of sensors within the engine bay, interpreting the data using multidimensional performance maps (called lookup tables), and adjusting the engine actuators accordingly.

Here ECU consists of a printed circuit board (PCB) assembly contained the plastic housing. The PCB assembly is electrically connected to the following hardware within the throttle body: air intake temperature sensor, air pressure sensor, throttle position sensor and idle flow actuator. .

Key Elements:

1. Micro Controller
2. Memory
3. Inputs
4. Outputs
5. Communication Links
6. Throttle Body and In-built Sensors

Specification:

Operating Voltage: 8 to 16 V

Operating temperature: -20°C to 85°C

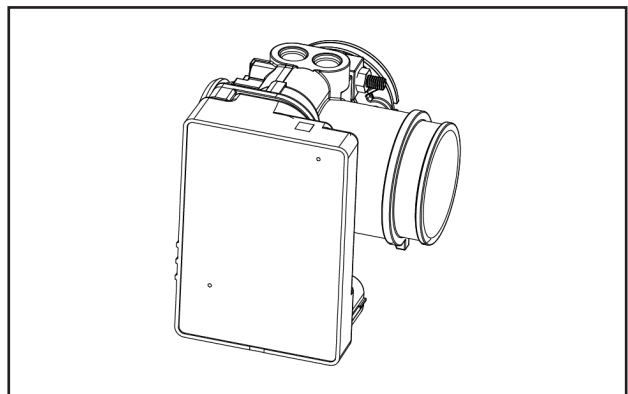

2. Fuel Injector

Fuel injector use pintle valves are operated by electromagnetic components called solenoids. The solenoid is activated, or “pulses” by an ECU which causes it to undergo linear movement.

Since the solenoid is mechanically connected to a pintle valve within the fuel injector, the linear movement causes the pintle to move away from its seat. A small amount of highly pressurized fuel then sprays from the pintle nozzle.

Specification:

Resistance: $12\Omega \pm 0.6\Omega$ at $21 \pm 2^\circ\text{C}$

Operating Voltage : 6 to 16 V

Operating Pressure: 200-600 kPa

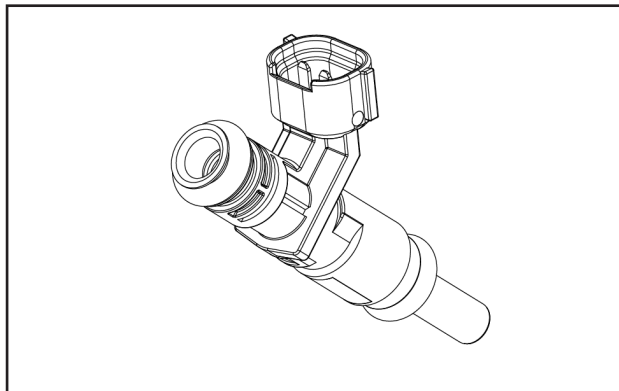

3. Fuel Supply Module

The Fuel pump is located on the left bottom of the tank and submerged in the fuel so that it cannot ignite itself due to any electrical short circuits. The fuel pump has a micro filter which helps to filter even the minute dust particles that may come in the fuel. The pressure regulator maintains the pressure of 350 kPa pushing the gasoline to the injector.

Specification:

Operating Voltage: 8 to 16 V

Operating Fuel Pressure: 350 ± 14 kPa

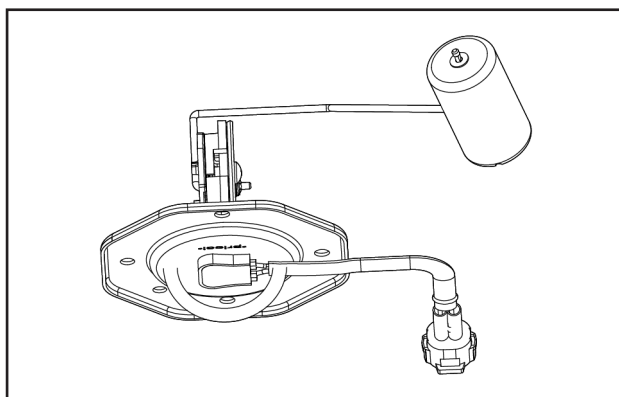

4. Throttle Position Sensor

A Throttle Position Sensor (Tps) is used to monitor the position of the throttle operation. Sensor is embedded in ECU PCB. It is a contactless type sensor, based on the Magneto-Resistive effect. It measures magnetic field angle variation from a magnet inked to throttle shaft and provides variable voltage depending upon the position of the butterfly valve and hence throttle position can be sensed by the ECU. The sensor signal is used by the ECU as an input to its control system. The ignition timing and fuel injection timing (and potentially other parameters) are altered depending upon the position of the throttle, and also depending on the rate of change of the position.

The ECU uses the throttle valve position to know:

- Engine mode: Idle, Part Throttle, Wide-Open Throttle.
- Air-fuel ratio correction.
- Acceleration/ Deceleration correction.

5. Manifold Absolute Pressure Sensor (MAP)

The Manifold Absolute Pressure sensor provides instantaneous manifold pressure information to the ECU. This is necessary to calculate air density to determine the required fuel metering for optimum combustion and influence the advance or retard of ignition timing. This sensor is built in the ECU.

6. Canister Purge Valve

The purge valve is the part of the vehicle Evaporative Emission Control (EVAP) system. The EVAP system prevents fuel vapors in the fuel tank from escaping into the atmosphere. The EVAP system traps fuel vapors from the fuel tank and temporarily stores them in the charcoal canister, see the diagram. When the engine is running under certain conditions, the fuel vapors are purged from the canister and burned inside the engine. The purge valve precisely controls the amount of fuel vapor that is purged from the charcoal canister. It opens only when engine oil is 60°-170° c and HEGO sensor "Controller ON".

Specification:

Valve: Normally Closed

Resistance: $26 \pm 2\Omega$ @ 20°C

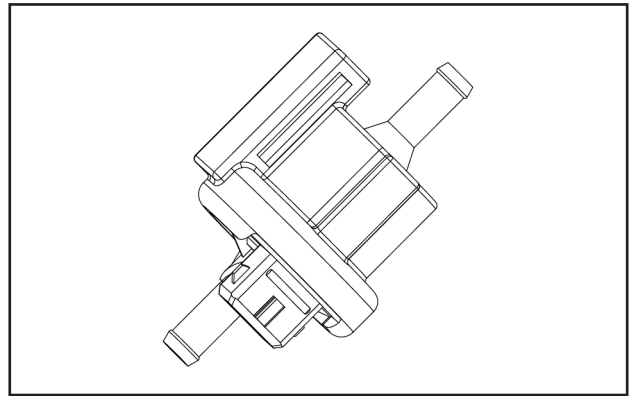

7. HEGO Sensor/Oxygen Sensor (HEGO / O2)

The Heated Exhaust Gas Oxygen sensor detects the presence of oxygen in the exhaust and produces a variable voltage according to the amount of oxygen detected. The O2 sensor provides feedback to the ECU indicating air/fuel ratio in order to achieve a near stoichiometric air/fuel ratio of 14.7 : 1 during closed loop engine operation. The ideal mixture is the amount of fuel needed to make an engine perform as commanded by the ECU.

The HEGO sensor is a voltage generator which is installed upstream from the catalytic converter. The heated exhaust gas oxygen sensor will generate a voltage signal that is characteristic of this ideal stoichiometric ratio. The HEGO sensor operates as a reference-gas sensor, and compares the residual oxygen in the exhaust gas with the oxygen in the reference atmosphere (air circulating inside the sensor). The active sensor ceramic is heated by the internal heating element; thus sensor heating reduces the influence of the exhaust gas temperature on the sensor-ceramic temperature and therefore the temperature-dependent sensor. Reliable signals working temperature from 300°C to 900°C maximum.

Specification:

Operating Voltage: 16 V (Max)

Operating temperature: 600°C to 950°C

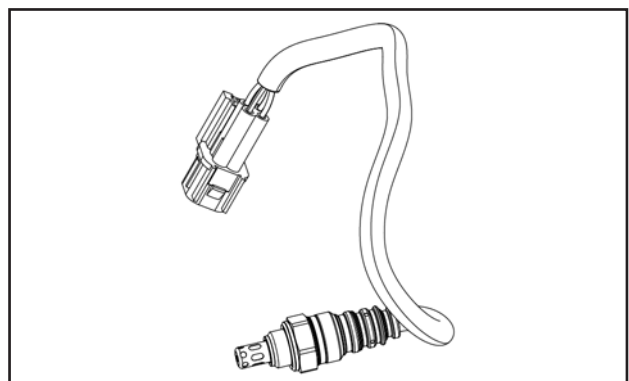

8. Idle Air Control Valve (IAC)

Idle Air Control Valve is basically a stepper motor controlling the bypass air to the engine and helps to idle and cold start the engine without difficulties. The ECU accordingly collects the data from the engine oil temperature and intake air temperature sensors and operates the stepper motor in regulating the engine RPM. This allows the engine's idle speed to be maintained constant. Idle Air Control Valve is in built in the ECU.

9. Engine Oil Temperature Sensor (EOT)

Engine oil temperature sensor is thermistor whose resistance is dependent on temperature. It has a Negative Temperature Coefficient where the resistance decreases with increase in temperature. It gives the average temperature of the engine oil to the ECU for making corrections in the injection quantity, ignition timing and for adjusting the stepper opening for better idle stability. It is mounted in LH of cylinder head.

Specification:

Operating Temperature: -55 to 250°C

Supply Voltage: 5 V

Pin Out Voltage: 3.79 V @ 40°C (Across Pins 19 & 22)

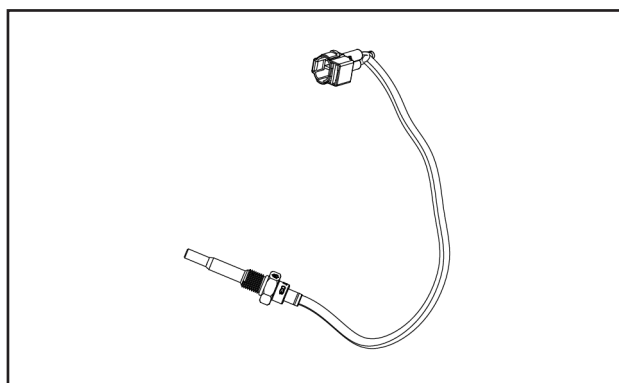

10. Intake Air Temperature Sensor (IAT)

Intake air temperature sensor is also a Negative Temperature Coefficient sensor where the resistance decreases with increase in temperature. It gives the information about ambient air temperature to the ECU for making corrections in the injection quantity and ignition timing. This intake air temperature sensor is in-built in ECU.

- NOTE:**
1. To meet target emission
 2. To meet evaporative emission.

11. Clutch Switch

Clutch switch gives information to the ECU about the clutch status (i.e) engaged or disengaged with the gearbox. The clutch switch gives digital input to the ECU (i.e) 0 or 1 which will help in starting of the vehicle when the engine is not in neutral gear. It is mounted under the LH switch module at handle bar.

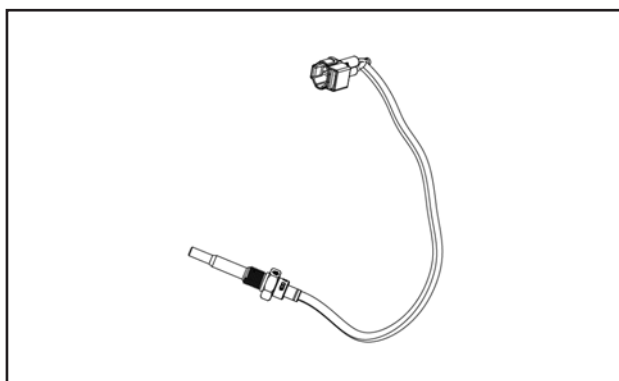

12. Side Stand Switch

Side stand switch prevents the vehicle from starting when the side stand is down and not in neutral gear. It is rotary type switch, which is directly connected to ECU.

Specification:

(Across Pins 17 & 1)

Side stand down: 0 V

Side stand up: 12 V

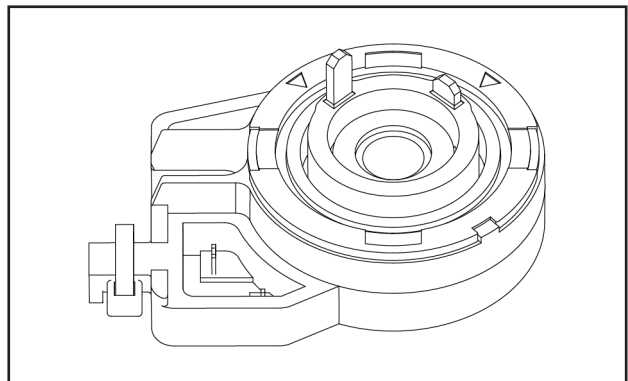

13. Gear Position Sensor (GPS)

Instrument cluster receives the Gear information from Gear position sensor and indicates in the Instrument cluster and also transmits this gear information to ECU through CAN communication. With this gear data ECU performs drive ability calculations in the ECU.

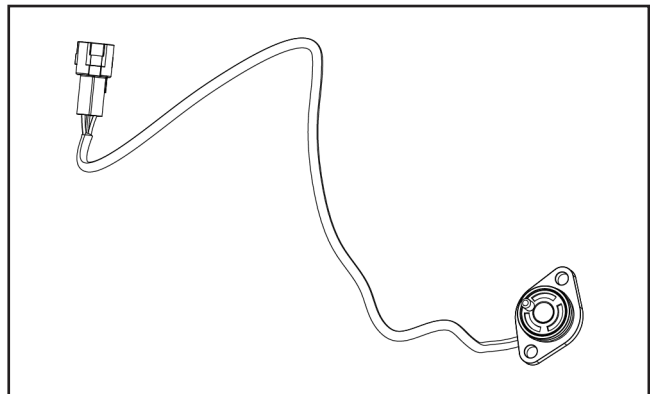

14. Roll Over Sensor

Roll over sensor is also known as bank angle sensor. This sensor gives signal to the ECU if the vehicle rolls off during any mishap or accident. The ECU then cuts off the supply to the fuel injector and the spark plug thus stalling the vehicle, due to which further major mishap is avoided. This sensor is In-built in the ECU.

Specification:

Banking angle: 50 degrees

15. Crank Position Sensor (CPS)

It provides an alternating electrical pulse to the ECU, to determine crankshaft speed and TDC position of the piston in compression stroke. This input will help the ECU to optimize both fuel injection as well as Ignition advance required to suit the crankshaft rotation speed (RPM).

In the event throttle is wide open, leading to crankshaft speed above 6850 RPM, the high frequency electrical pulses from the crank position sensor will prompt the ECU to restrict fuel supply so that the crank speed reduces to safe levels. This is a safety aspect to prevent damage to moving engine parts. CPS is located inside the engine cover LH, under the stator coil.

Specification:

Output Voltage: 2.5V to > 85 V AC

Resistance : $215\Omega \pm 10\Omega$

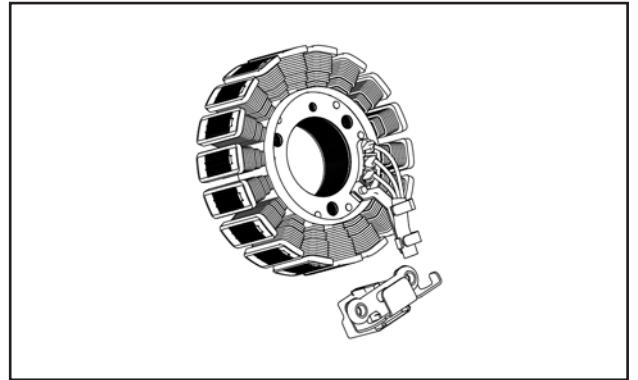

16. Starter Motor Relay

Specification:

Operating Voltage: 9 to 16 V

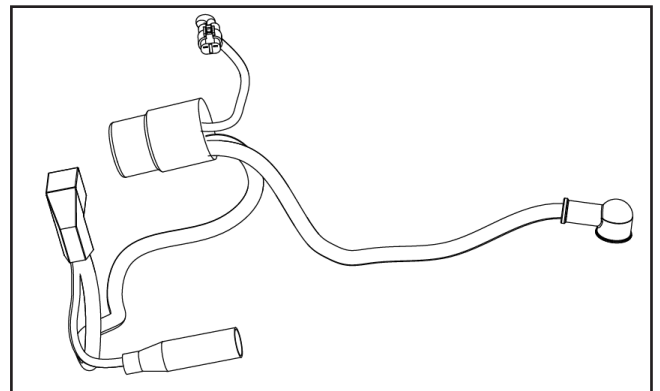

Idling Adaptation procedure

⚠ CAUTION

Idling adaptation should be done only if any changes in ECU, EMS sensors or in fuel type of the vehicle.

Step 1 - Check the Engine Oil Temperature (EOT) at start is less than **35°C**.

Step 2 - Start and allow the engine to idle and leave it undisturbed till the engine oil temperature reaches **115°C**. (Time required for the EOT to reach 115°C is 30 minutes approximately)

Step 3 - Once the engine oil temperature reaches **115°C**, turn OFF the engine and **DO NOT** turn it on for 30 Seconds.

10.1 Engine Management System (EMS)

Dismantling

10.1.1. Engine Control Unit (ECU)

⚠ CAUTION

Before disconnecting ECU from the wiring harness, the battery terminals must be disconnected from the battery.

- Ensure the ignition switch and stop switch are in OFF position.
- Remove the following:
 - Side panel RH ([section 6.7.1](#)).
 - Side panel LH ([section 6.7.4](#)).
 - Seat from frame ([section 6.7.2](#)).
- Disconnect battery terminals ([section 11.5.1](#)).
- ECU is main part of EMS and is located in the throttle body.
- ECU cannot be dismantled from the Throttle body, hence has to be replced as a whole assembly.
- Disconnect the coupler **(a)** from the ECU **(b)**.

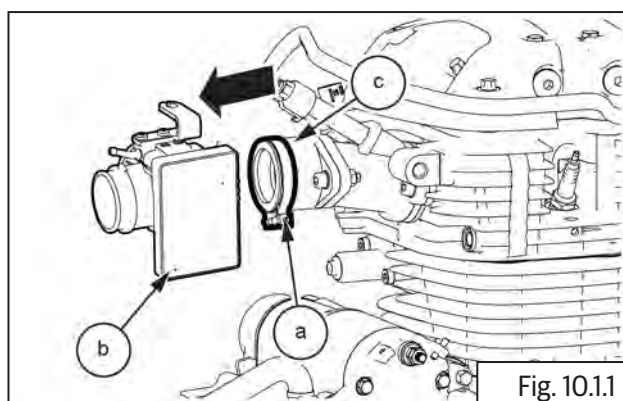

- Refer section for throttle body dismantling..

⚠ CAUTION

Ensure locks are fully lifted up and released before disconnecting wiring connectors from ECU.

Ensure locks are handled with care and do not get damaged or broken.

Damaged or broken locks will result in loose connections and cause the ECU to fail.

Storage of ECU

Do's & Don'ts

- Store ECU away from any magnetic forces at it will affect the ECU program software and damage ECU.
- Store ECU in a cool and dry place.
- DO NOT allow moisture to affect the ECU.
- DO NOT wash the ECU with water or any solvent.
- Prevent ECU from any external damages.
- DO NOT drop ECU or allow it to fall as internals will get damaged and render the ECU defective.
- DO NOT keep any heavy or sharp objects on ECU as it will damage internals and render the ECU defective.

10.1.2. Fuel Pump

- Ensure Ignition switch and Engine stop switch are in OFF position
- Remove the following parts:
 - Side panel RH ([section 6.7.1](#)).
 - Rider seat ([section 6.7.2](#)).
 - Fuel tank assembly ([section 7.1.1](#)).

⚠ CAUTION

Ensure the following:

Fuel is drained completely from fuel tank.

Fuel feed and return hoses are disconnected from the fuel rail.

Wiring couplers to fuel pump and low fuel sensor are disconnected.

EVAP hose pipes are disconnected.

⚠ WARNING

Gasoline is extremely flammable and highly explosive. Improper handling can lead to fatal accident or serious injury.

- Loosen and remove 4 Nos. Hex socket head bolts **(M5) (a)** holding fuel pump to tank.

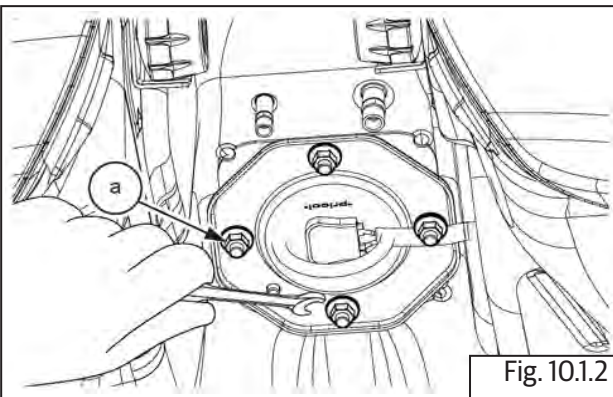

8 mm Socket with Ratchet

- Gently pull out the fuel pump **(a)** from fuel tank **(b)**.

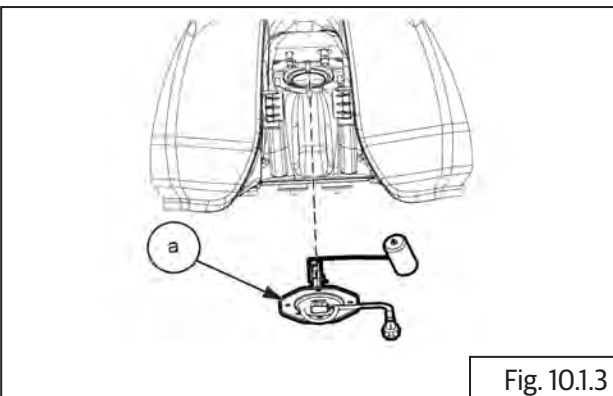

- Remove O-rings **(a)** and **(b)** from fuel pump **(c)**.

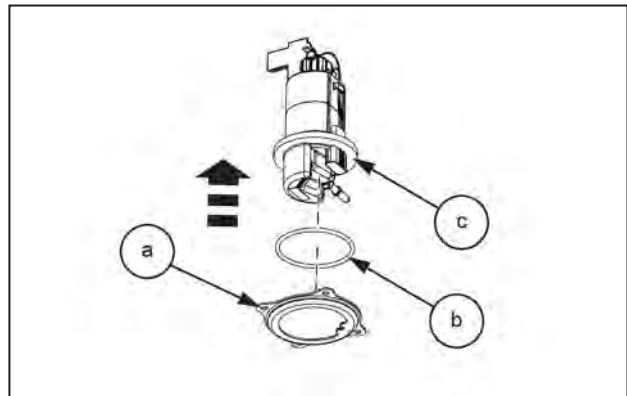

10.1.3. Throttle Body Assembly

- Ensure ignition switch and engine stop switch are in OFF position
- Remove the following parts:
 - Side panel RH ([section 6.7.8](#)).
 - Rider seat ([section 6.7.7](#)).
 - Side panel LH ([section 6.7.5](#)).
 - Fuel tank assembly ([section 7.1.15](#)).

⚠ CAUTION

Ensure the following:

Fuel is drained completely from fuel tank.

Fuel hoses are disconnected.

Wiring couplers to fuel pump and low fuel sensor are disconnected.

EVAP hose pipes are disconnected.

⚠ WARNING

Gasoline is extremely flammable and highly explosive. Improper handling can lead to fatal accident or serious injury.

- Remove the following parts:
 - Throttle cable ([section 5.1.8](#)).
 - Remove electrical connector from ECU.
 - Rubber hoses connecting to Throttle body from EVAP ([section 5.1.11](#)).

- Ensure vacuum hose is removed.
- Loosen wire clips on air filter connection tubes ([section 5.1.10](#)).
- Loosen worm clip screw on inlet manifold. ([section 5.3.19](#)).

NOTE

- Ensure screw is sufficiently loosened and the worm clip rotates easily in the groove in the manifold.

- Gently pull out throttle body from the inlet manifold rubbers along with fuel rail and injectors.

10.1.4. Fuel Injectors

- Disconnect coupler **(a)** from injector.

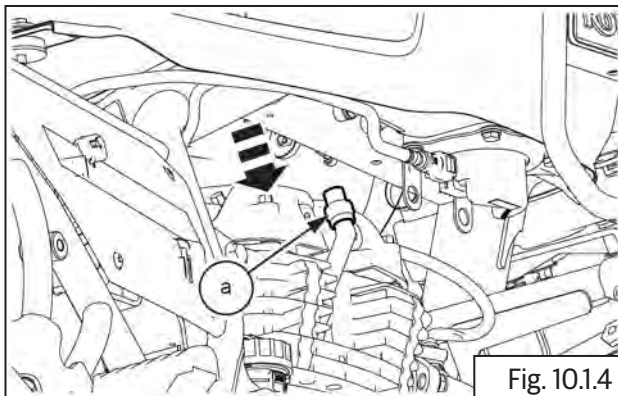

- Loosen and remove 1 No. Hex flange bolts **(a)** holding from fuel injector **(b)** to cylinder head.

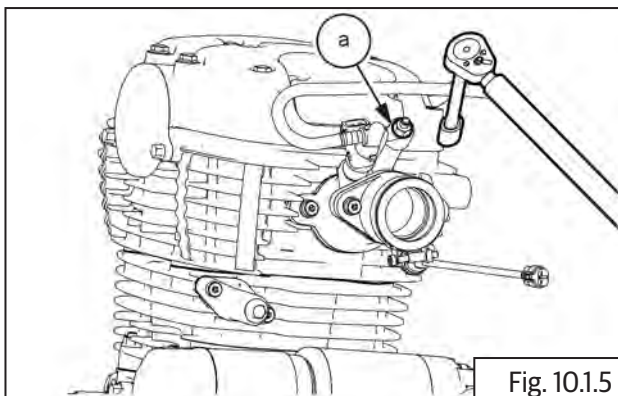

10 mm Socket with Ratchet

- Gently remove injector.

10.1.5. Engine Oil Temperature Sensor (EOT)

- The EOT **(a)** is located on cylinder head below the exhaust pipe.

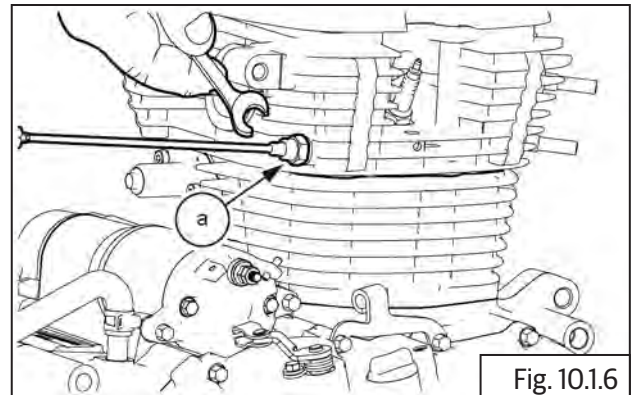

NOTE

- Ensure the engine is cold before dismantling EOT.
- Ensure Ignition switch and Engine stop switch are in OFF position.

CAUTION

Do not remove EOT from cylinder head when the engine is hot.

- Disconnect EOT sensor wiring coupler from the main harness above cylinder head.
- Place a small tray under EOT to collect the oil when it is loosened and removed.
- Insert EOT wiring coupler through a deep grooved ring spanner and locate the spanner on the EOT hex head correctly.
- Gently loosen EOT from cylinder head and remove along with O-ring.

10.1.6. HEGO/Oxygen (O2) Sensor

⚠ CAUTION

Do not loosen/remove HEGO (O2) sensor when the exhaust pipes are hot.

⚠ WARNING

The engine and exhaust systems get extremely hot during normal operation and can result in serious burns if touched. Make sure exhaust pipes are not hot and is at the same levels of ambient/surrounding temperature whenever working on the engine or exhaust systems.

- The HEGO (O2) sensor is located on the exhaust pipe.
- Disconnect HEGO (O2) sensor connector from wiring harness located under fuel tank.
- Gently loosen HEGO (O2) sensor **(a)** from exhaust pipe and remove along with Copper washer.

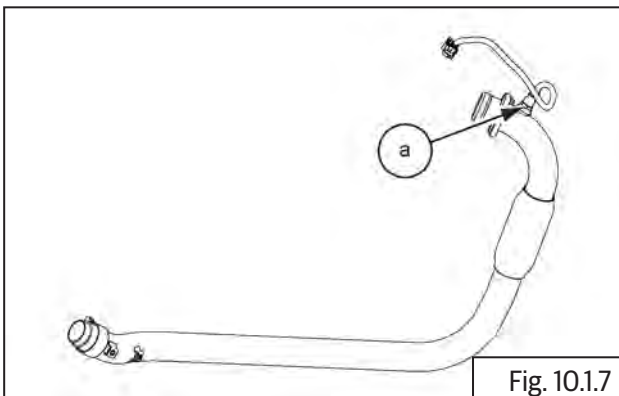

17 mm Deep groove ring spanner

10.1.7. Purge Valve

- Remove the following parts:
 - Side panel RH ([section 6.7.1](#)).
 - Rider seat ([section 6.7.2](#)).
 - Side panel LH ([section 6.7.4](#)).
- The purge valve is part of the EVAP system and is located above the cylinder head to frame.
- Disconnect hose **(a)** connecting purge valve **(b)** to throttle body.

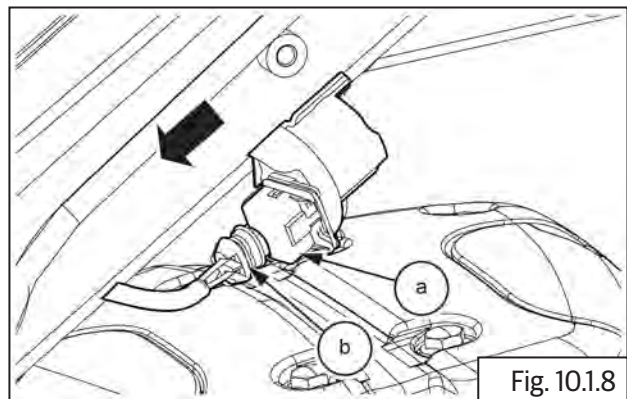

- Disconnect hose **(a)** connecting purge valve to canister.

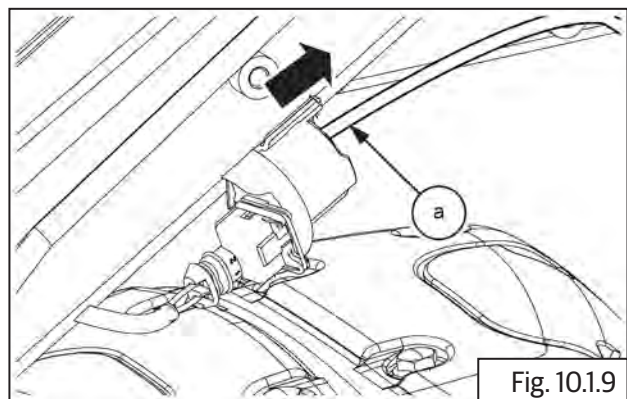

- Disconnect wiring coupler from purge valve.
- Gently pull out purge valve from bracket.

10.1.8. Ignition Coil

- The Ignition coil is located on the frame under fuel tank.
- Ensure Ignition switch and Engine stop switch are in "OFF" position.
- Remove the following parts:
 - Side panel RH ([section 6.7.1](#)).
 - Rider seat ([section 6.7.2](#)).
 - Side panel LH ([section 6.7.4](#)).

⚠ WARNING

Gasoline is extremely flammable and highly explosive. Improper handling can lead to fatal accident or serious injury.

- Disconnect spark plug suppressor cap from spark plug **(a)**.

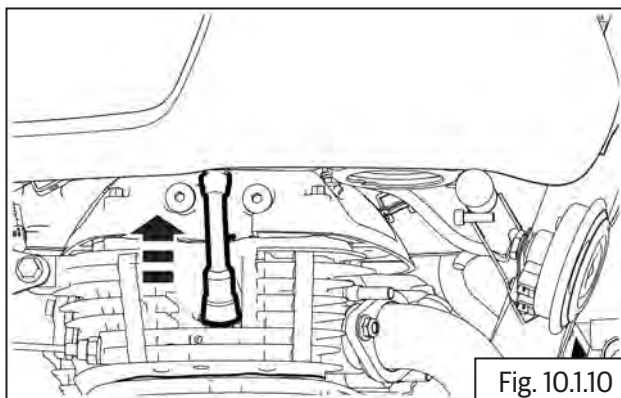

- Disconnect wiring couplers from the ignition coil.
- Loosen and remove. Hex head bolts Gently slide out Ignition coil from frame and remove along HT cables.

10.1.9 Crank Position Sensor

- The crank position sensor is located inside the engine cover LH and attached to the stator coil.
- Ensure Ignition switch and Engine stop switch are in "OFF" position.
- Disconnect wiring coupler **(a)** of stator from main wiring harness.

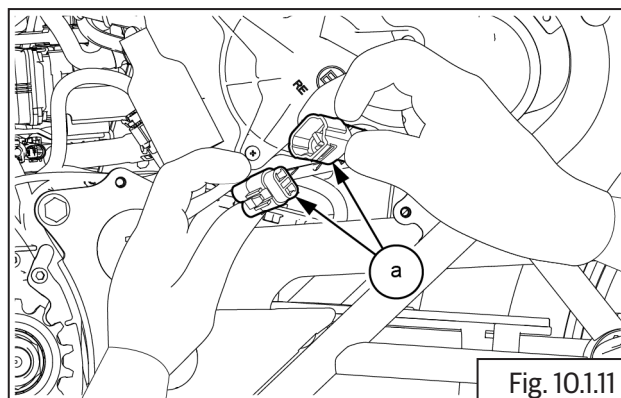

- Remove FD sprocket cover ([section 5.1.24](#)).
- Remove cover LH from Engine ([section 5.1.34](#)).
- Loosen and remove 3 Nos. Allen socket head screws **(M6) (a)** holding stator coil.

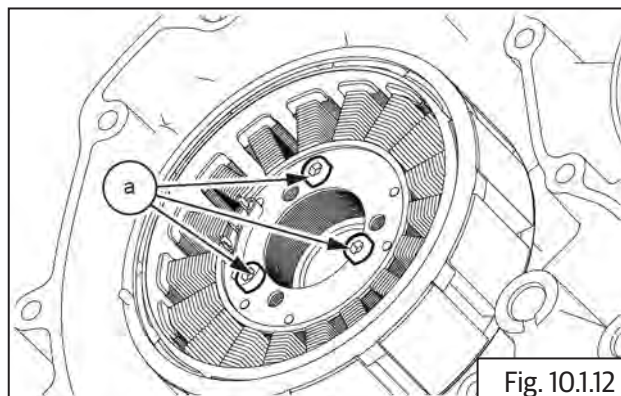

5 mm Allen Socket with Ratchet

- Loosen and remove 2 Nos. Allen socket head bolts **(M5) (a)** holding crankshaft position sensor guide plate to cover LH.

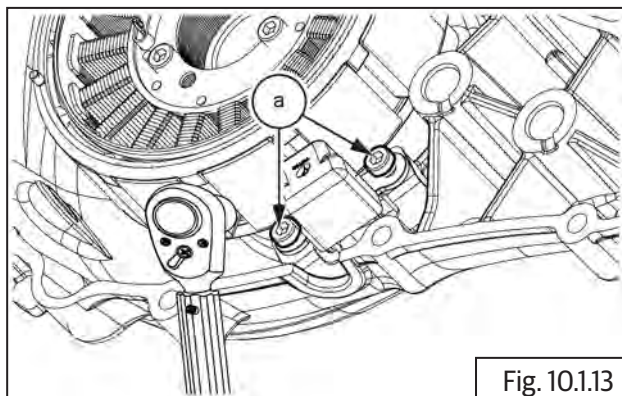

Fig. 10.1.13



4 mm Allen Socket with Ratchet

- Gently slide out wiring harness, rubber grommet **(b)** from the slot in cover LH and remove stator coil along with crank shaft position sensor **(a)**.

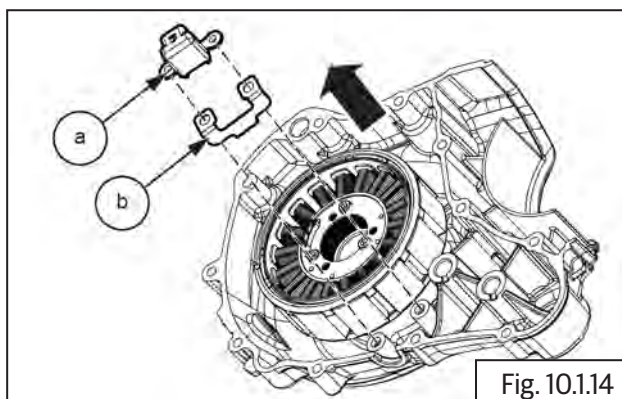

Fig. 10.1.14

10.1.10. Gear Position Sensor

- The gear position sensor is located on the crankcase LH before FD sprocket.
- Ensure Ignition switch and engine stop switch are in OFF position.
- Disconnect wiring coupler **(a)** of gear position sensor from main wiring harness **(b)**.

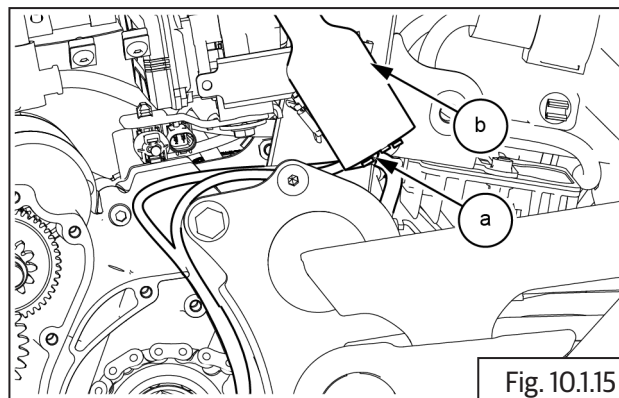

Fig. 10.1.15

- Remove FD sprocket cover ([section 5.1.24](#)).
- Loosen and remove 2 Nos. Hex head bolts **(M6) (a)** holding the gear position sensor to crankcase LH.
- Gently tap Gear Position Sensor and remove along with O-ring.

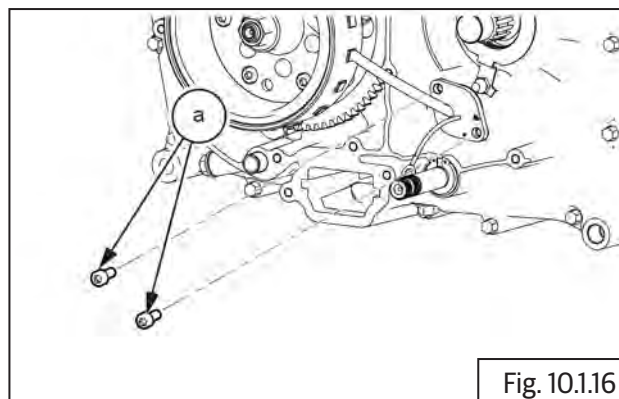

Fig. 10.1.16



10 mm Socket with Ratchet

- Remove cable bracket **(a)** and gently pull out gear position sensor from crankcase LH.

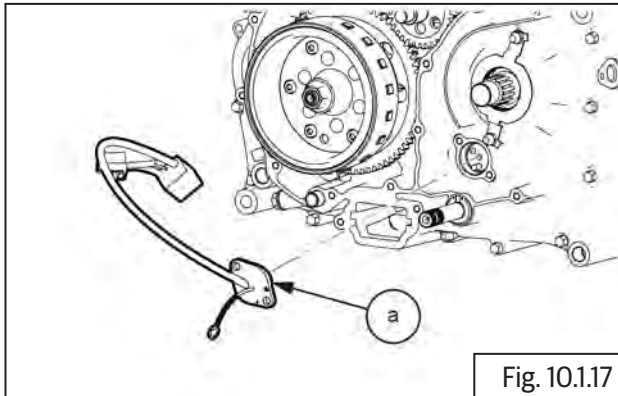

Fig. 10.1.17

10.1.11. Clutch Switch

- Remove headlamp assembly ([section 11.1.1](#)).
- Disconnect clutch switch connector **(a)**.

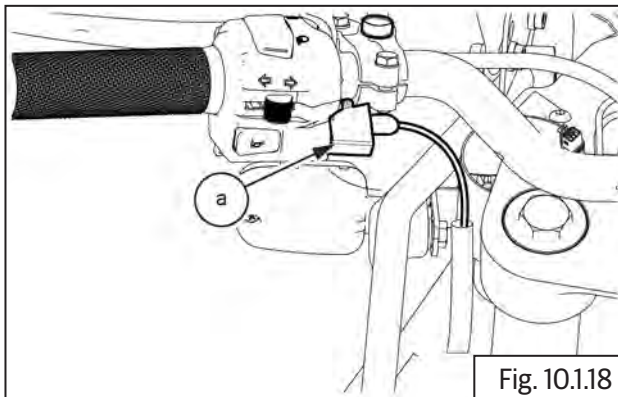

Fig. 10.1.18

- Loosen and remove 2 Nos of screws **(a)** from clutch lever **(b)**.

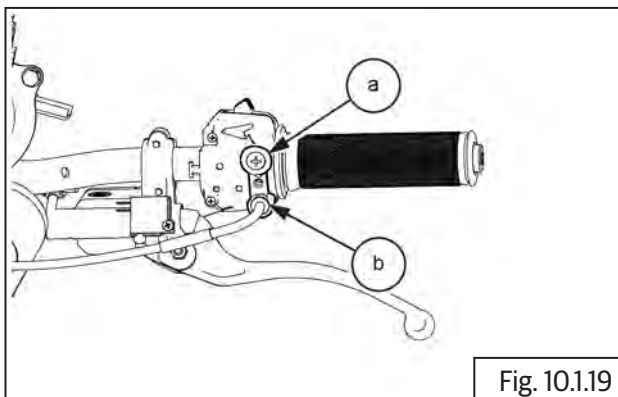
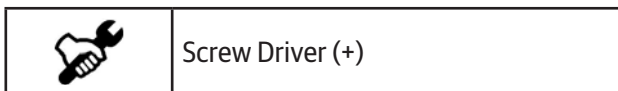

Fig. 10.1.19



Screw Driver (+)

10.1.12. Side Stand Switch

- Place the vehicle in main stand.
- Disconnect side stand connector **(a)** from wiring harness located behind engine.

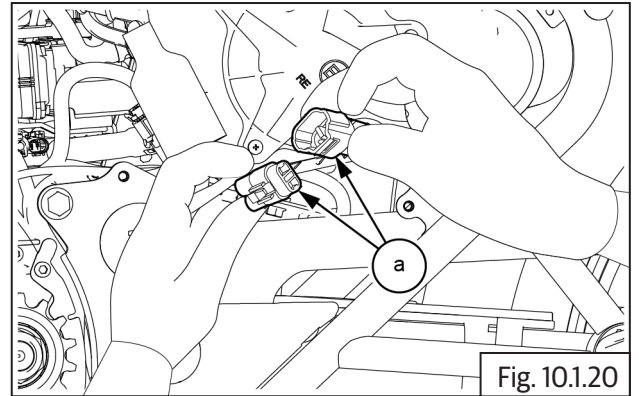

Fig. 10.1.20

- Release the side stand.
- Loosen and remove Hex socket head cap screw **(M6) (a)** from side stand switch located on side stand.

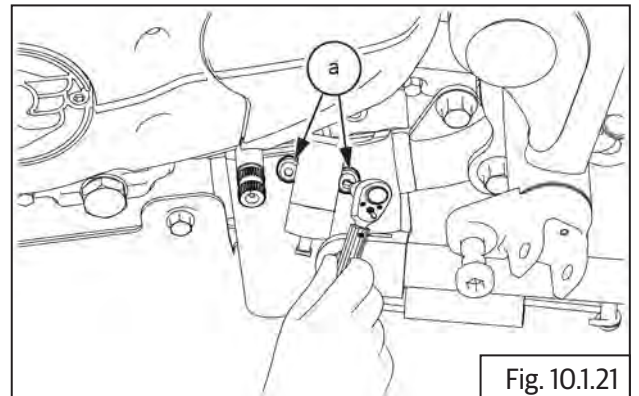

Fig. 10.1.21



10 mm socket With Ratchet

- Remove side stand switch **(a)**.

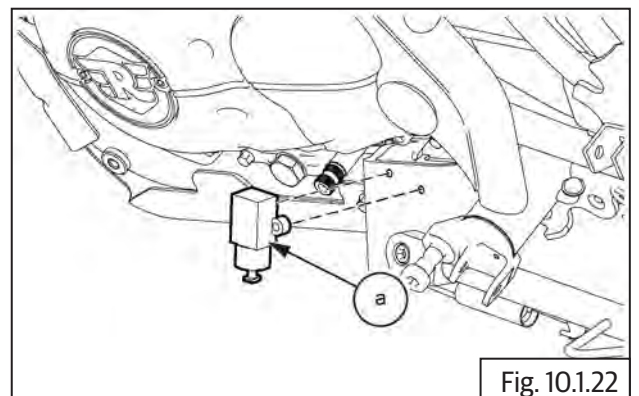
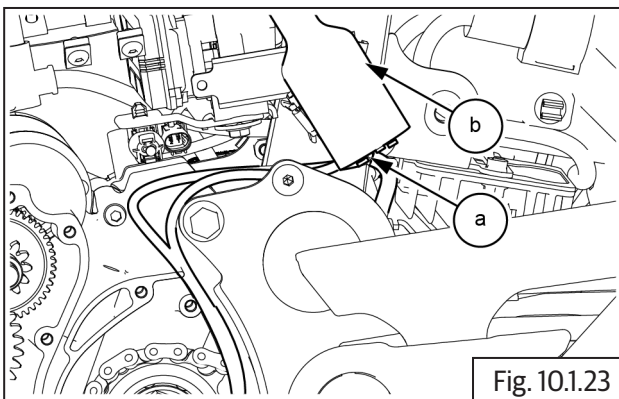

Fig. 10.1.22

10.1.13. Starter Motor Solenoid

- Remove the following parts:
 - Rear wheel ([section 6.8.3](#)).
 - Rear mudguard in fill cover ([section 6.6.7](#)).
- Locate solenoid connectors below battery tray, ensure ignition off.
- Disconnect starter solenoid connectors **(a)** from wiring harness **(b)** located below battery tray.



- Gently slide and remove solenoid coil from battery bracket.

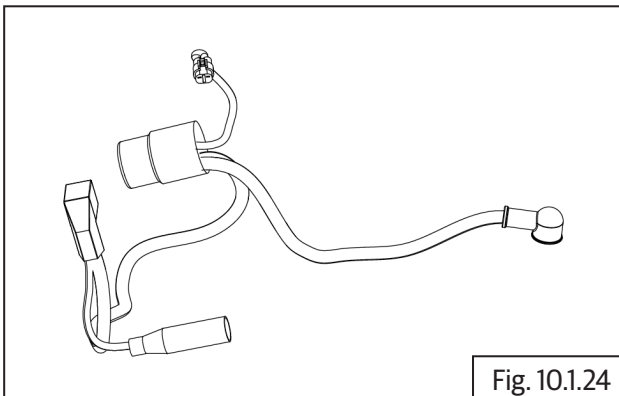

Assembly

10.1.14. Engine Control Unit (ECU)

⚠ CAUTION

Before assembling any part of the EMS, the Ignition switch and Engine stop switch MUST be in OFF position

Before connecting ECU into wiring harness, the battery terminals must be disconnected from the battery.

- Insert throttle body **(b)** into intake manifold flange **(c)** and tighten lock clip **(a)**

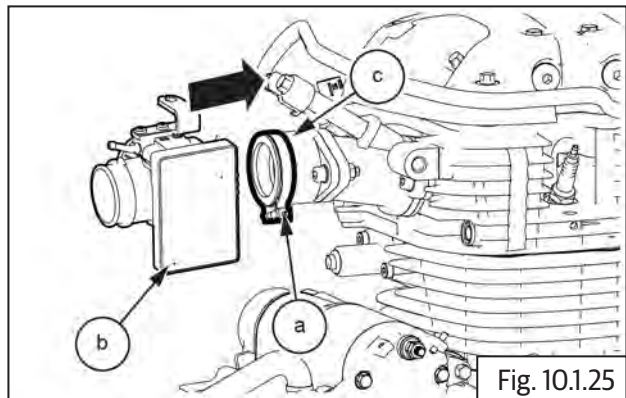

4 mm Allen socket With Ratchet

- Insert throttle body rear end in the air box opening **(a)**.

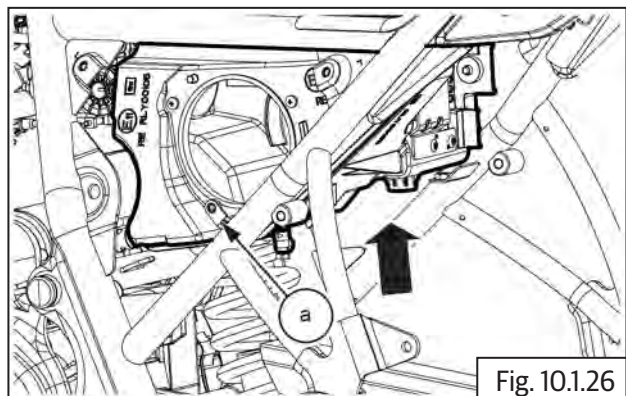

- Tighten the lock clip.

- Connect wiring harness coupler **(a)** to ECU **(b)**.
- Connect battery terminals.
- Assemble rider seat ([section 6.7.7](#)).
- Assemble side panel RH ([section 6.7.8](#)).

10.1.15. Fuel Pump

- Ensure Ignition switch and engine stop switch are in "OFF" position.
- Gently insert fuel pump **(a)** from fuel tank along with O-ring.

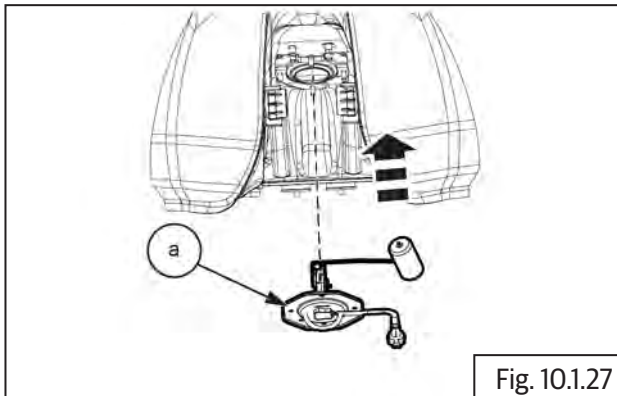

- Locate and tighten 4 Nos. Hex socket head nuts **(M5) (a)** holding fuel pump to fuel tank.

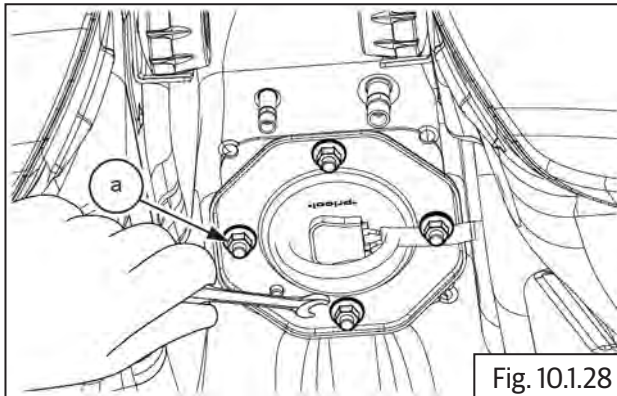

	10 mm socket with Ratchet
Torque	8-12 N-m/0.8-1.2 kgf-m

- Assemble fuel tank assembly ([section 7.1.15](#)).

⚠ CAUTION

Ensure the following:

Fuel is refilled into fuel tank.

Fuel feed and return hoses are connected into fuel rail.

Wiring couplers to fuel pump and low fuel sensor are connected.

EVAP hose pipes are connected.

Water drain hose are connected.

⚠ WARNING

Gasoline is extremely flammable.

- Assemble rider seat ([section 6.7.7](#)).
- Assemble side panel RH ([section 6.7.8](#)).

10.1.16. Fuel injectors

- Fuel injectors are located on the intake manifold.
- Ensure the O-rings **(a)** and **(b)**.

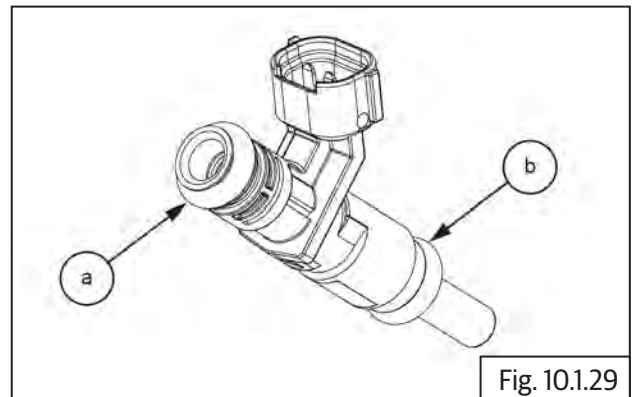

- Gently assemble injectors into manifold along with upper and lower O-rings .
- Locate and tighten 2 Nos. Hex soc bolts **(M5)** into injector mounting.
- Assemble throttle body ([section 5.2.31](#)).

⚠ CAUTION

Ensure the following:

Fuel is refilled into fuel tank.

Fuel feed and return hoses are connected into fuel rail.

Wiring couplers to fuel pump and low fuel sensor are connected.

EVAP hose pipes are connected.

Water drain hose are connected.

- Assemble the following parts:
 - Fuel tank ([section 7.1.15](#)).
 - Rider seat ([section 6.7.7](#)).
 - RH side cover ([section 6.7.8](#)).

10.1.17. Engine Oil Temperature Sensor (EOT)

- Locate EOT sensor along with O-ring into engine head assembly.
- Tighten EOT sensor Hex head **(M17) (a)** into engine head assembly **(b)**.

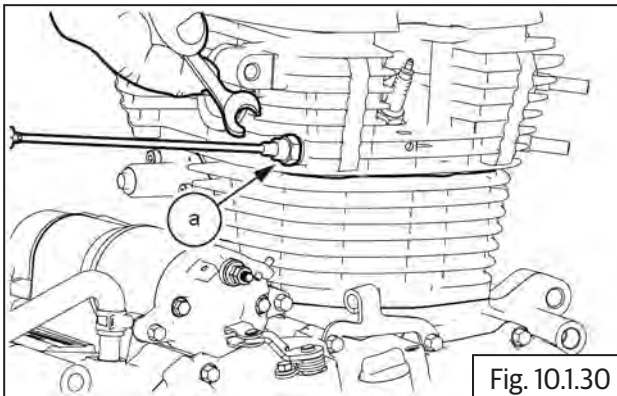

	17 mm Deep groove spanner
Torque	8-10 N-m/0.8-1.0 kgf-m

- Connect EOT sensor connector into wiring harness above cylinder head.
- Ensure connector is locked and wire is routed correctly.

10.1.18. HEGO (O2) Sensor

- The HEGO sensor are located on the exhaust pipes near the cylinder head.

⚠ WARNING

The engine and exhaust systems get extremely hot during normal operation and can result in serious burns if touched. Make sure exhaust pipes are not hot and is at the same levels of ambient/surrounding temperature, whenever working on the engine or exhaust systems.

NOTE

- Ensure the engine/exhaust is cold before assembling the HEGO (O2) sensors.
- Ensure Ignition switch and Engine stop switch are in OFF position.

- Locate HEGO/O2 sensor on the exhaust pipe and tighten.

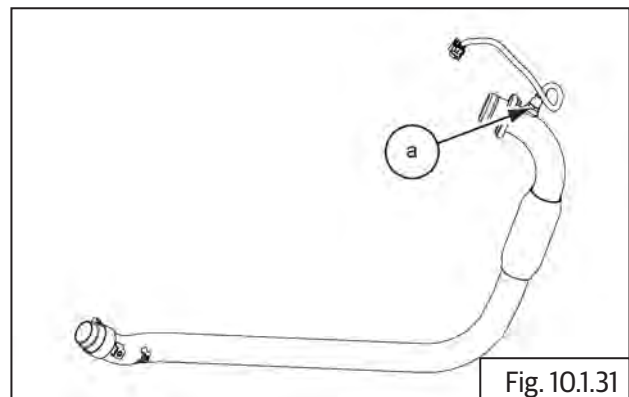

	17 mm Deep groove spanner
---	---------------------------

- Connect HEGO sensor connector from wiring harness located near ignition coil assembly below fuel tank.

10.1.19. Purge Valve

- Locate and install EVAP purge control valve into frame.
- Connect the inlet **(a)** and outlet **(b)** hoses to EVAP purge control valve.
- Connect the electrical connector to EVAP purge control valve.

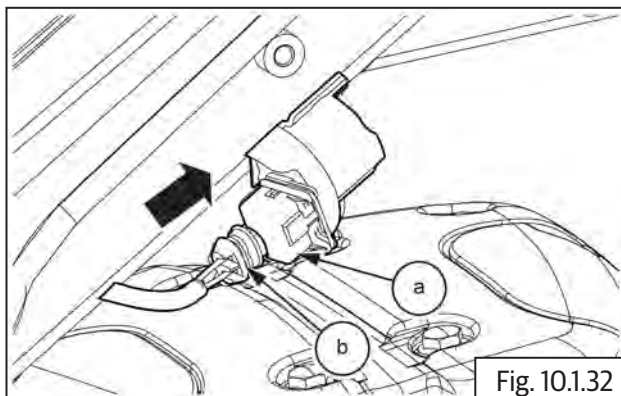

Fig. 10.1.32

- Assemble the following parts:
 - Side panel LH ([section 6.7.5](#))
 - Rider seat ([section 6.7.7](#)).
 - Side panel RH ([section 6.7.8](#)).

10.1.20. Ignition Coil

- Assemble ignition coil into frame.
- Insert and tighten 2 Nos. hex soc bolts **(M6)** into ignition coil.
- Connect ignition coil connector from wiring harness located below fuel tank.
- Gently insert Spark plug suppressor cap into spark plug.
- Assemble fuel tank ([section 7.1.15](#)).

⚠ CAUTION

Ensure the following:

Wiring couplers to fuel pump and low fuel sensor are connected.

EVAP hose pipes are connected.

Water drain hose are connected.

⚠ WARNING

Gasoline is extremely flammable.

- Assemble rider seat Assembly ([section 6.7.7](#)).
- Assemble side panel RH ([section 6.7.8](#)).

10.1.21. Crank Position Sensor

- The crank position sensor is located inside the engine cover LH and attached to the stator coil.
- Locate starter coil along with crank shaft position sensor wire assembly into cover LH.
- Locket and tighten 2 Nos Allen socket head screws **(M5) (a)** into guide plate.

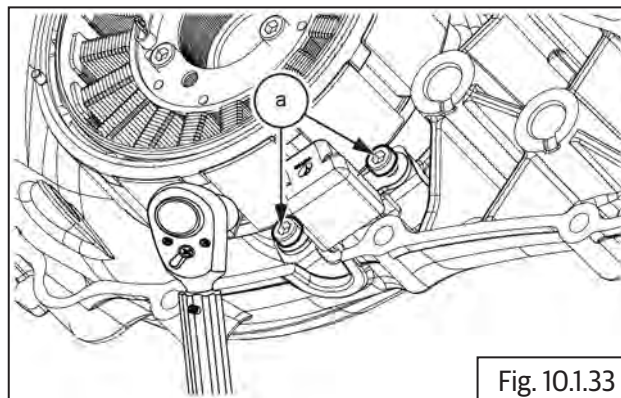

Fig. 10.1.33



4 mm Allen key with Ratchet

Torque

8-10 N-m/0.8-1.0 kgf-m

- Locate and tighten 3 Nos. Allen socket head screws **(M6) (a)** into LH cover that hold starter coil.

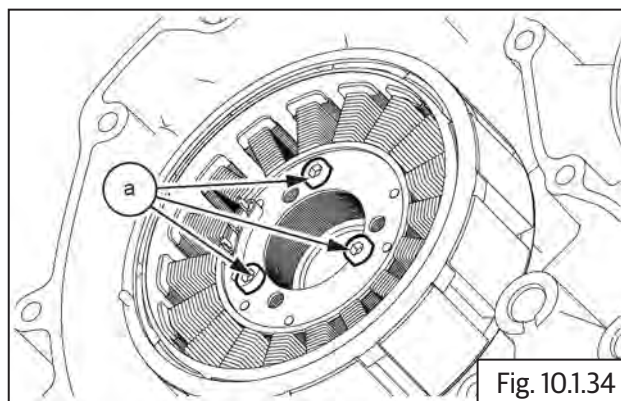

Fig. 10.1.34



5 mm Allen key with Ratchet

Torque

8-10 N-m/0.8-1.0 kgf-m

- Locate crank shaft position sensor and wiring harness behind engine on RH, near RR module.
- Connect crank position sensor connector to harness connector.
- Ensure the wiring harness strapped properly.
- Assemble the following parts:
 - FD sprocket cover ([Section 5.2.54](#)).
 - Cover LH from Engine Refer ([Section 5.2.45](#)).
 - Fill engine oil.

10.1.22. Gear Position Sensor

- The gear position sensor is located on the crankcase LH before FD sprocket
- Ensure Ignition switch and Engine stop switch are in OFF position.
- Gently locate gear position sensor **(a)** below FD sprocket.

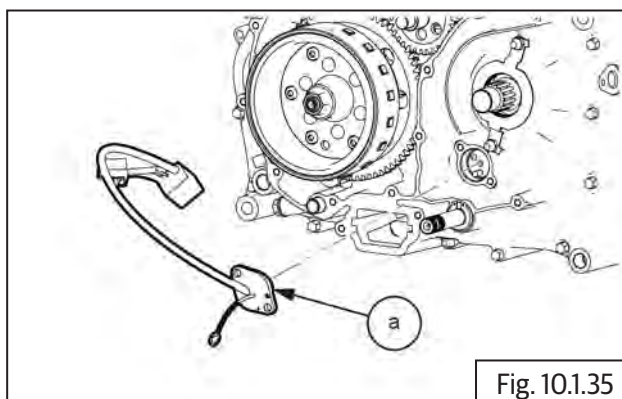

- Insert and tighten 2 Nos. Allen head bolts **(M6)** located below FD sprocket.

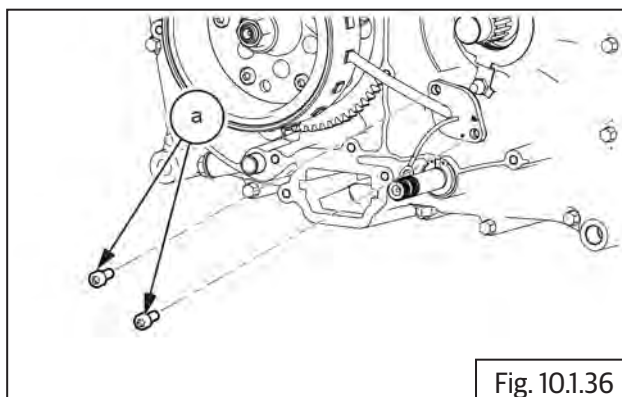

	8 mm Allen socket With Ratchet
Torque	8-10 N-m/0.8-1.0 kgf-m

- Connect gear position sensor connector **(a)** to wiring harness connector located on rear side of engine **(b)**.
- Ensure connector is locked properly and wiring is routed correctly.
- Assemble FD sprocket cover ([Section 5.4.12](#)).

10.1.23. Clutch Switch

- Locate and tighten 2 Nos of screws **(a)** into clutch lever **(b)**.

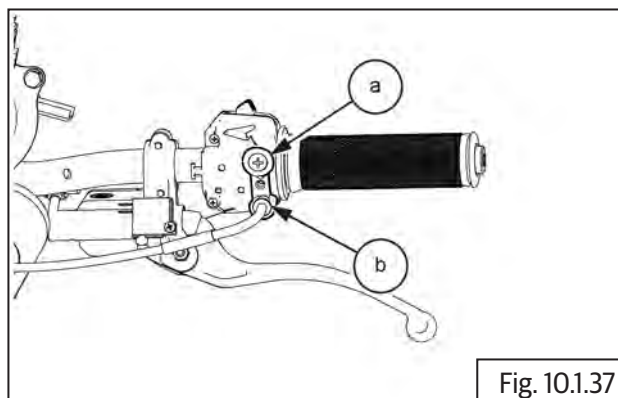

	Screw Driver (+)
--	------------------

- Connect connectors **(b)** into clutch switch on handlebar LH **(a)**.

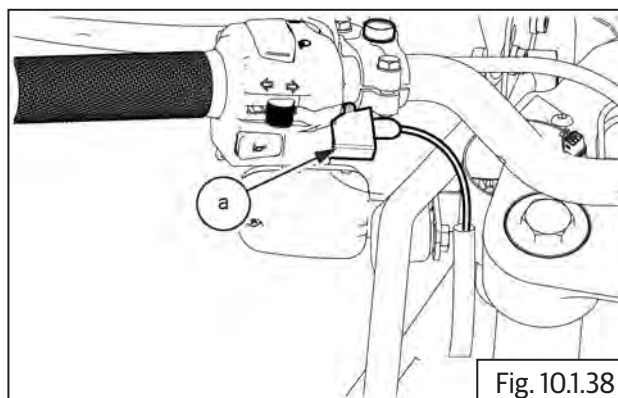

- Assemble headlamp assembly ([section 11.12.8](#)).

10.1.24. Side Stand Switch

⚠ CAUTION

Ensure the motorcycle is upright on a firm and flat surface.

- Ensure vehicle is placed in main stand
- Ensure side stand is released.
- Locate switch on the slots provided over the side stand.

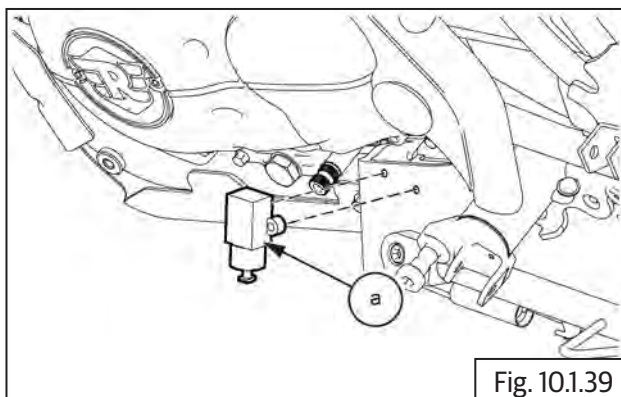

- Locate and tighten Allen socket head cap screw **(M6) (a)** into side stand switch located on side stand **(b)**.

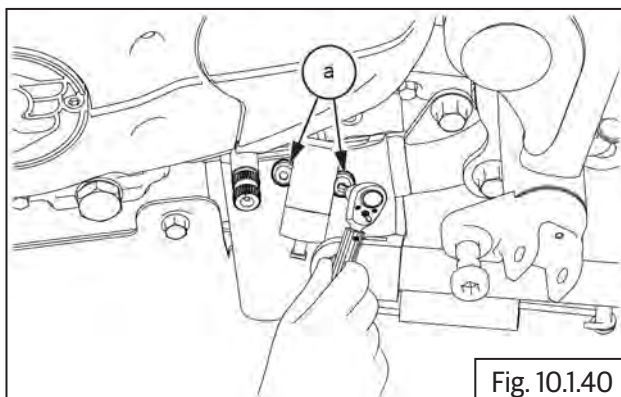

	12 mm Allen socket With Ratchet
Torque	8-10 N-m/0.8-1.0 kgf-m

- Connect side stand connector into wiring harness connector located behind engine frame RH.
- Ensure connectors are locked properly and routed correctly.

10.1.25. Starter Motor Solenoid

- Locate solenoid connectors below battery tray
Ensure ignition off.
- Gently slide and locate solenoid coil into battery tray bracket.

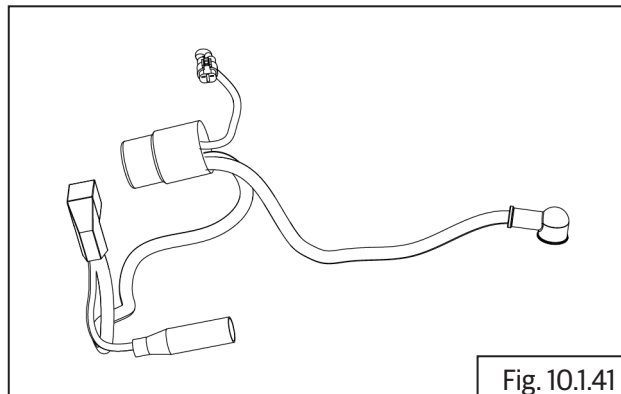

- Connect starter solenoid connectors **(a)** into wiring harness.
- Assemble the following:
 - Rear mudguard in fill cover ([section 6.6.10](#)).
 - Wheel speed sensor front and rear ([section 9.3.8](#)).

10.1.26 Actuator

Actuator Tests

- The following actuators can be tested for their functionality using the diagnostic tool/ PC software.
 1. Fuel Pump
 2. Injector
 3. Ignition Coil
 4. O2 sensor heater
 5. Malfunction Indication Lamp (MIL)
 6. Idle Air Control Valve (IACV)
 7. Canister Purge Valve (CPV)
 8. Secondary Air Injection Solenoid (SAI)
 9. Accessory Relay

Test Procedure

• Entry Conditions

1. Actuator tests can be carried out when the ignition key and kill switch are ON and engine speed is 0.
2. For IACV alone, engine speed can be greater than 0.
3. For actuation of injector and ignition coil, gear should be in neutral. If not in neutral, clutch lever should be pressed.
4. Errors associated to the corresponding actuator, if present, will inhibit the actuation.

• Procedure

A. In EOL software

1. Connect the tool with the diagnostic coupler in the vehicle and connect it with PC using the USB cable.
2. Select the option "EOL" & select Actuator.
3. Select the required actuator and press.

B. In NACSII tool

1. Connect the tool with the diagnostic coupler in the vehicle

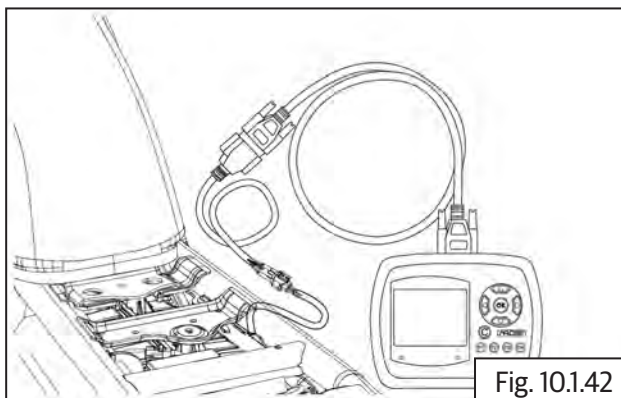

2. Select the vehicle model name and select Bosch Engine Management System
3. Select the option Actuator
4. Select the required actuator and press F3 to actuate

• Method of verification

4. For fuel pump, when actuated, an audible sound can be heard for 5 seconds .

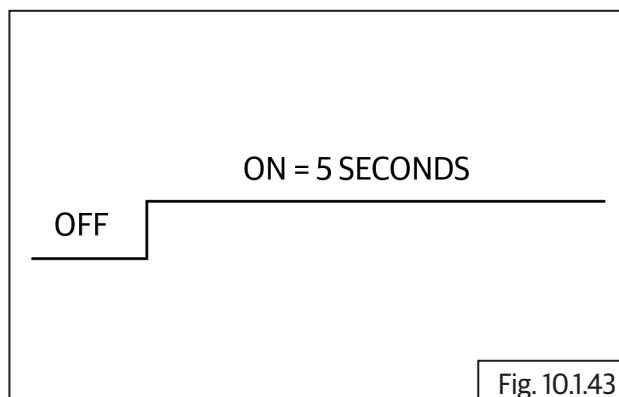

5. Prior to actuation of injector, prime the fuel pump 3 times to build up sufficient pressure in fuel line. To ensure injectors are working properly, remove the throttle body from the intake manifold, connect all the injector couplers and actuate. When actuated, 3 pulses of fuel spray from the injector can be seen.

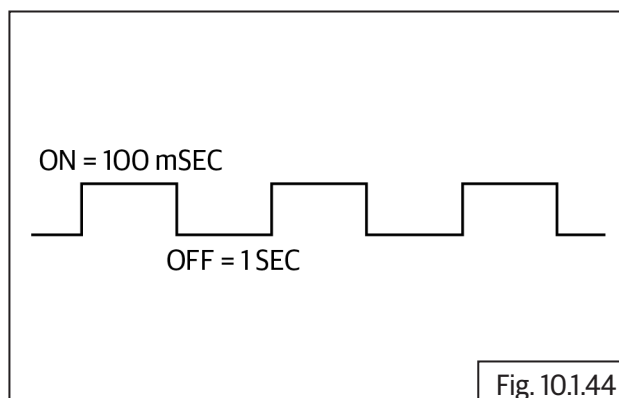

6. Prior to the actuation of ignition coil, remove the suppressor cap and connect with an external spark plug and ground it to engine. Do not ground the ignition coil directly. When actuated, 3 sparks can be seen.

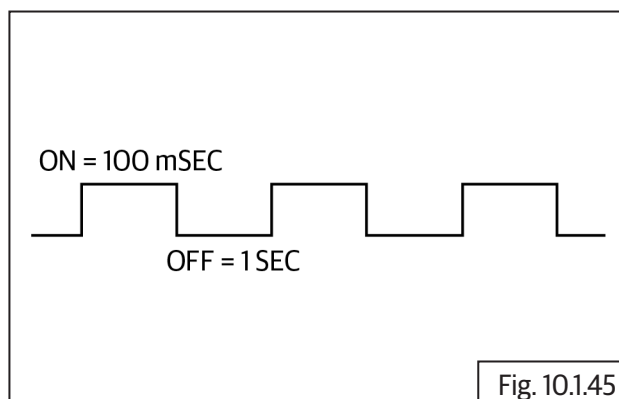

7. To check O2 sensor heater, the sensor has to be removed from the exhaust pipe. When actuation is requested, the sensor will get heated up and this happens for 5 seconds.

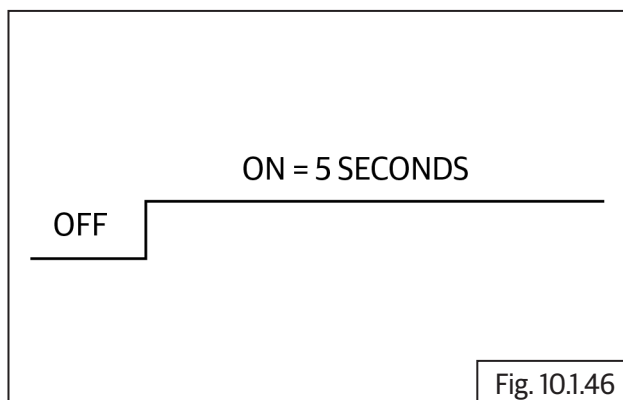

8. When MIL is actuated, the bulb goes ON & OFF for 5 times.

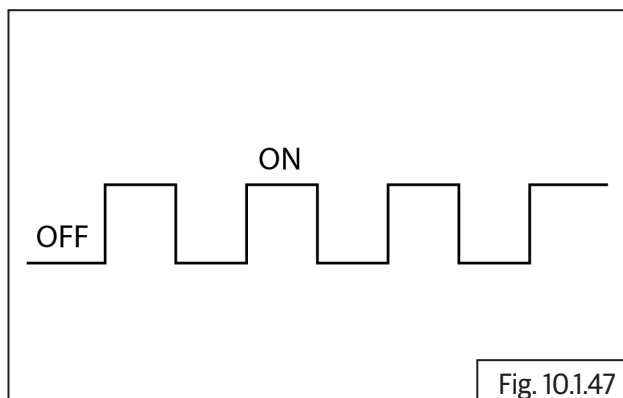

9. Start and idle the engine before actuating IACV. If actuation command is given, one can observe the engine rpm rising up & falling down the target idle speed. Once actuation is completed, it settles back to target idle speed.

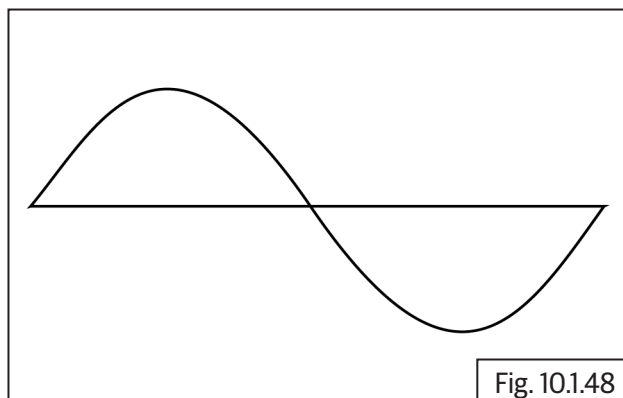

10. When CPV is actuated, a pulsating sound can be observed. If not, the canister purge valve has to be manually touched to feel actuation.

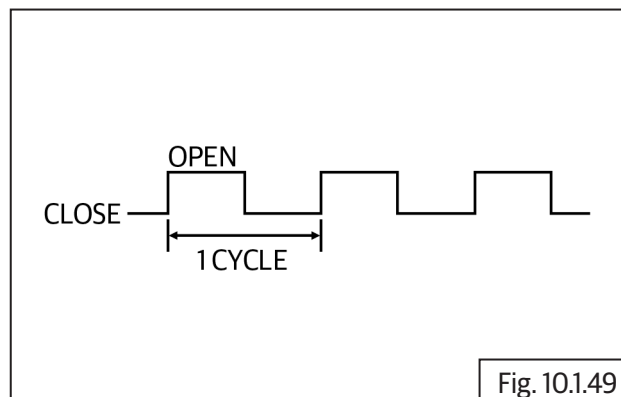

11. Accessory relay gets actuated for 5 cycles.

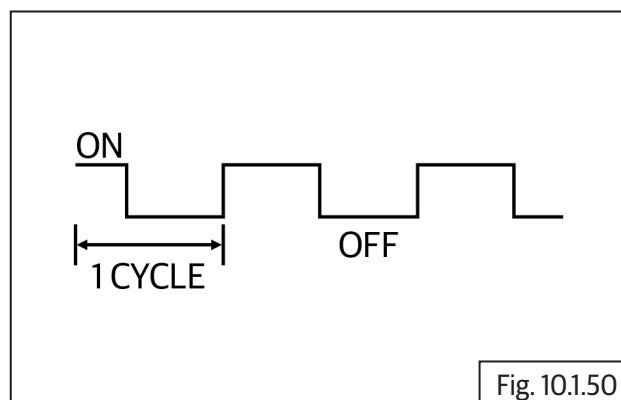

ELECTRICAL SYSTEM

CONTENTS	PAGE
Contents	
11. Electrical System.....	391
11.1 Headlamp and Cluster Dismantling	391
11.1.1 Headlamp Reflector from Housing	391
11.1.2 Headlamp Bulb from Reflector	392
11.2 Connectors behind Headlamp Housing.....	392
11.2.1 Instrument Cluster Dismantling.....	394
11.3 Tail Lamp Dismantling.....	395
11.3.1 Tail Lamp	395
11.4 Brake Lamp Connectors Dismantling	396
11.4.1 Brake Lamp Connector - Rear	396
11.4.2 Brake Lamp Connector - Front.....	396
11.5 Trafficators Dismantling	396
11.5.1 Direction Trafficators - Rear.....	396
11.5.2 Trafficator bulb - Front.....	397
11.6 Battery Dismantling.....	397
11.6.1 Battery Terminals	397
11.6.2 RR Unit	398
Inspection	399
Assembly	400
11.9 Battery Assembly.....	400
11.8.1 RR Unit.....	400
11.8.2 Battery Terminals.....	401
11.10 Trafficators Assembly.....	401
11.10.1 Direction Trafficator Bulb - Front.....	401
11.10.2 Direction Trafficators - Rear	401
11.11 Brake Lamp Connectors Assembly.....	403
11.11.1 Brake Lamp Connector - Rear	403
11.11.2 Brake Lamp Connector - Front.....	403

CONTENTS	PAGE
11.12 Tail Lamp Assembly.....	403
11.12.1 Tail Lamp	403
11.12.2 Cluster Assembly.....	404
11.12.3 Connectors and Sensors into Headlamp Housing.....	404
11.12.4 Headlamp Bulb into Reflector	406
11.12.7 Pilot Bulb into Reflector	406
11.12.8 Headlamp Reflector into Housing.....	406

11.1 Electrical System

11.1 Headlamp and Cluster Dismantling

11.1.1 Headlamp Reflector from Housing

NOTE

- Ensure ignition switch and stop switch in off condition

CAUTION

Support the Headlamp assembly carefully.

- Loosen and remove 2 No. Phillips screw (a) on both headlamp.

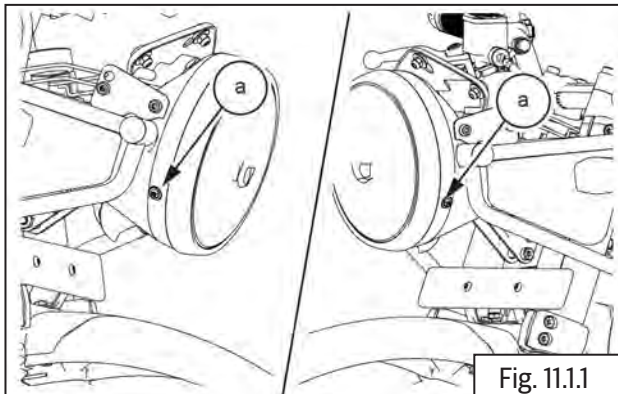

Phillips screw driver

- Gently remove front rim (a) along with reflector (b) from housing (c).

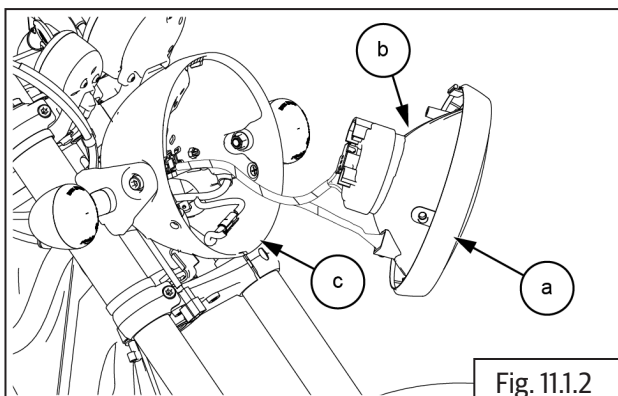

WARNING

The headlamp and bulb can be extremely hot. Do not remove while headlamp/bulb are hot.

- Hold headlamp head carefully and disconnect headlamp connector (a) from headlamp bulb.

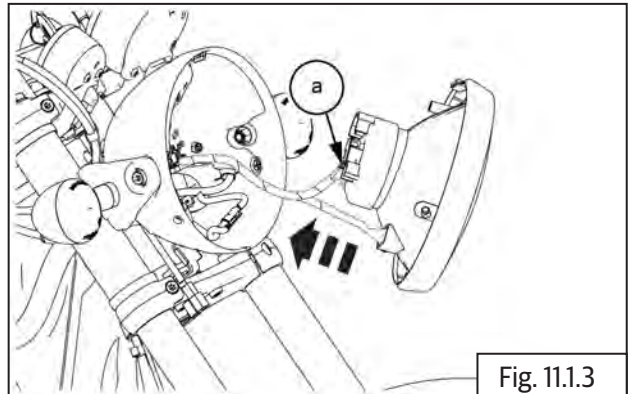

- Disconnect the position lamp connector (a).

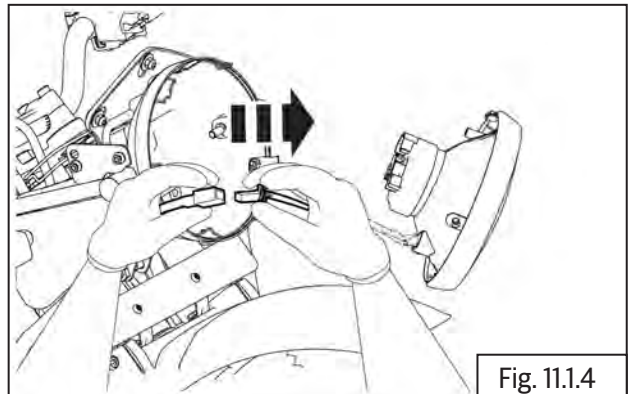

- Remove rubber boot (a) from the bulb.

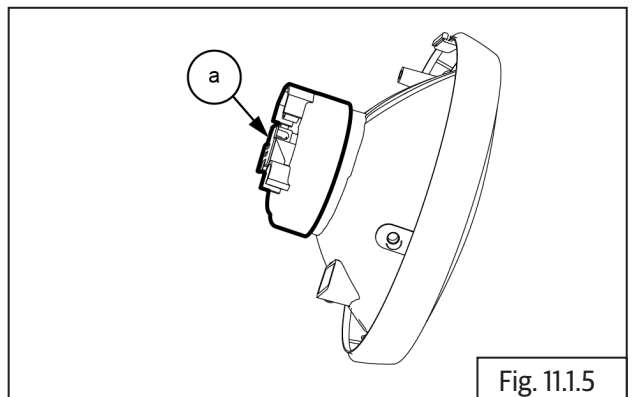

11.1.2 Headlamp Bulb from Reflector

- Depress wire clip **(a)** and release from slot **(b)** in headlamp reflector.

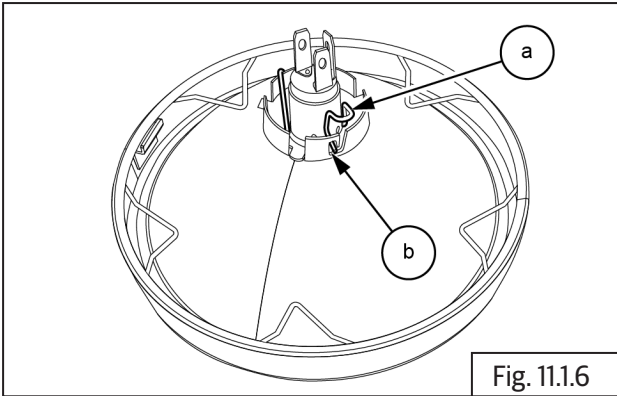

- Remove wire clip **(a)** from reflector **(b)** and gently pull out headlamp bulb **(c)** from reflector.

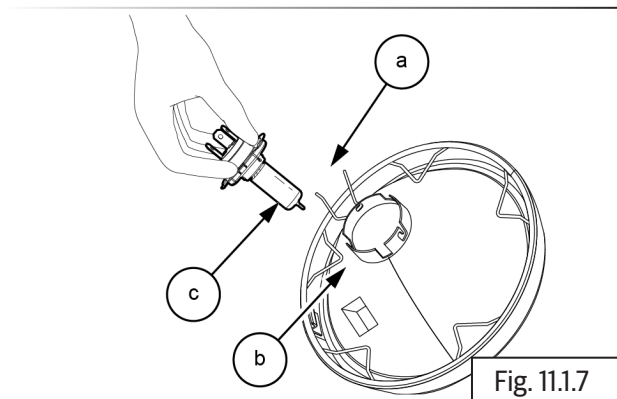

⚠ CAUTION

Do not touch glass of bulb. Any strains or finger prints will affect the luminosity.

Ensure pointed tip of bulb does not get damaged

Whenever handling the bulb, hold it firmly at terminal end and not at glass end.

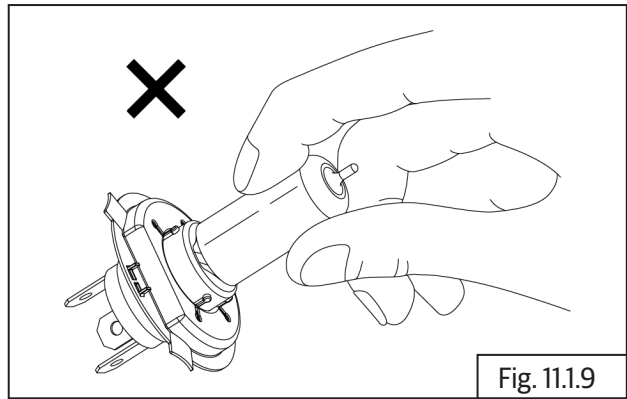
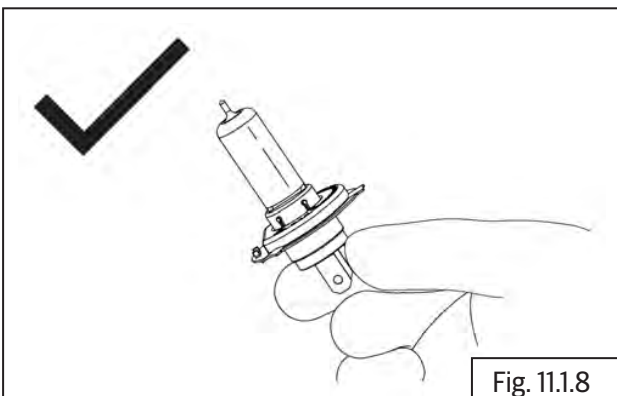

11.2 Connectors behind Headlamp Housing

- Disconnect LH module connector **(a)** from rubber boot.

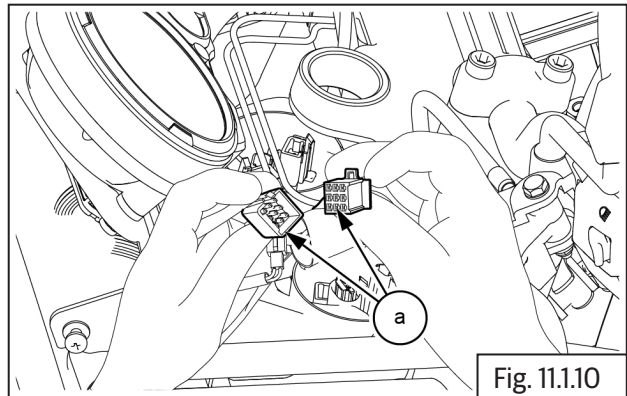

- Disconnect clutch switch connector **(a)**.

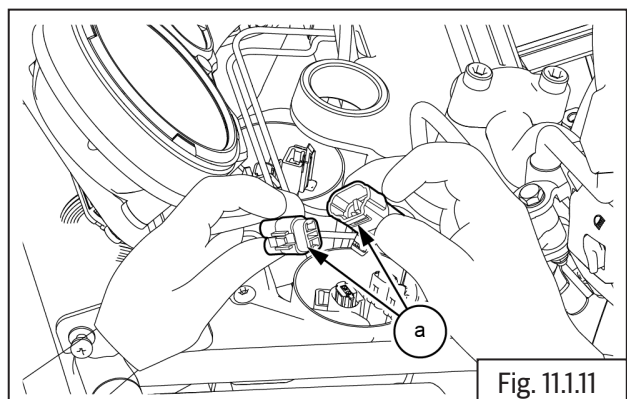

- Disconnect front brake lamp switch connector **(a)**.

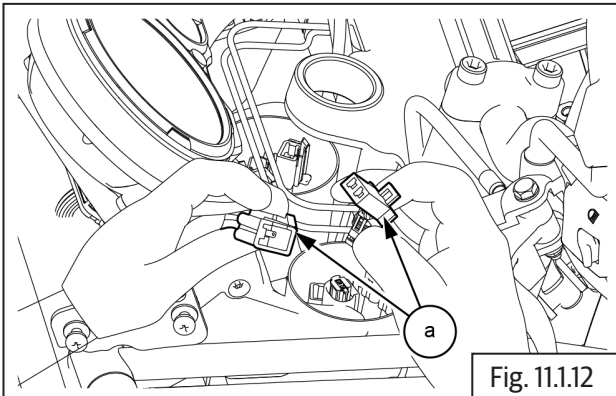

- Disconnect LH Trafficator connector **(a)**.

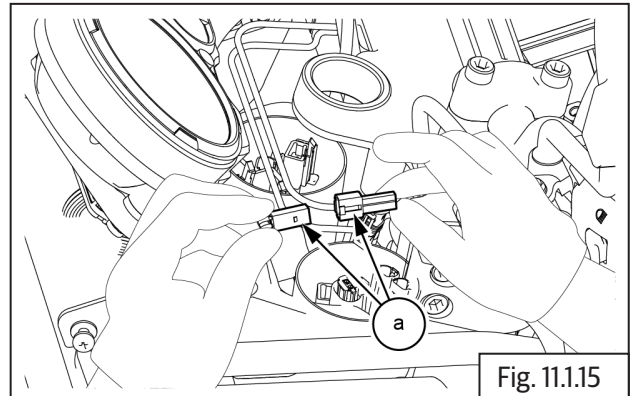

- Disconnect RH module connector **(a)**.

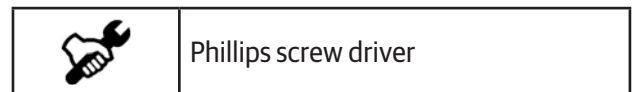
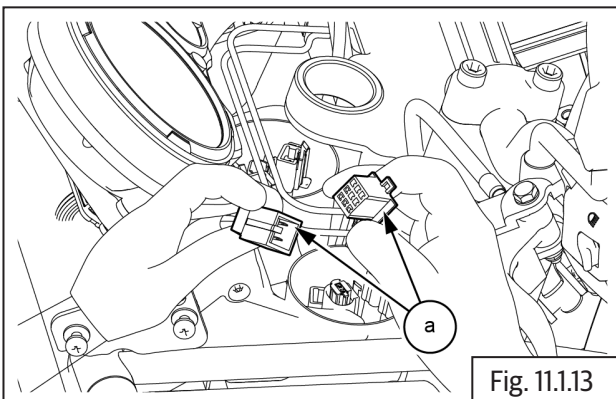

- Disconnect RH Trafficator connector **(a)**.

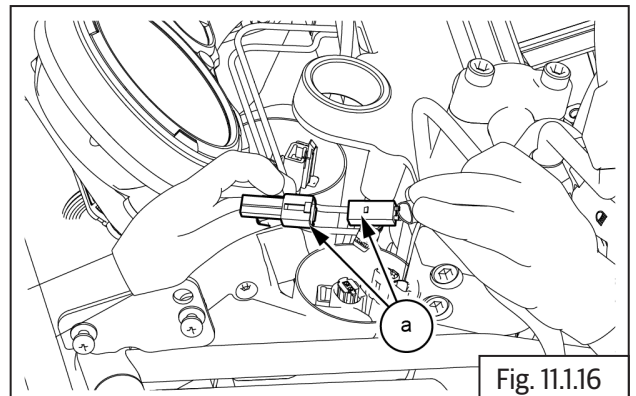

- Disconnect wheel speed sensor connector **(a)**.

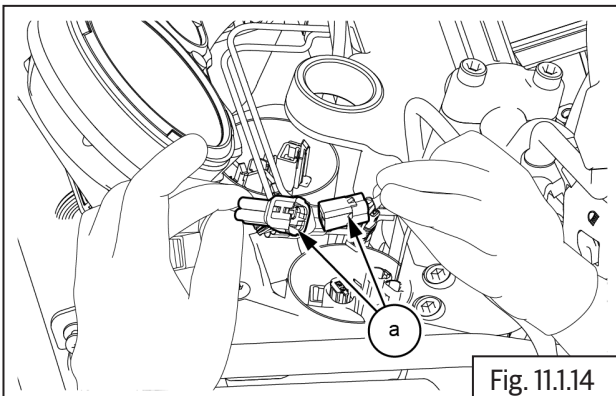

- Disconnect ignition switch connector **(a)**.

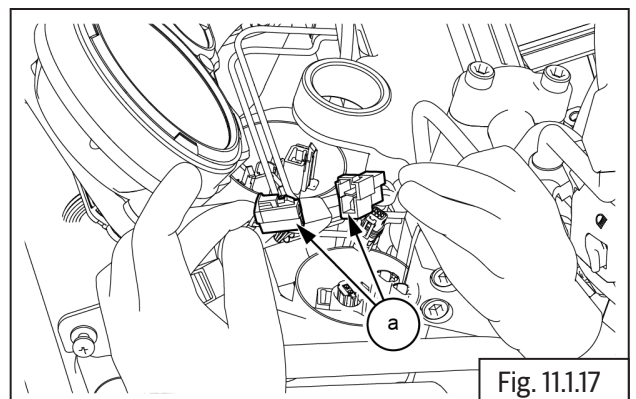

11.2.3 Instrument Cluster Dismantling

- Remove the 2 Nos. Philip screw **(a)** from LH wind shield.

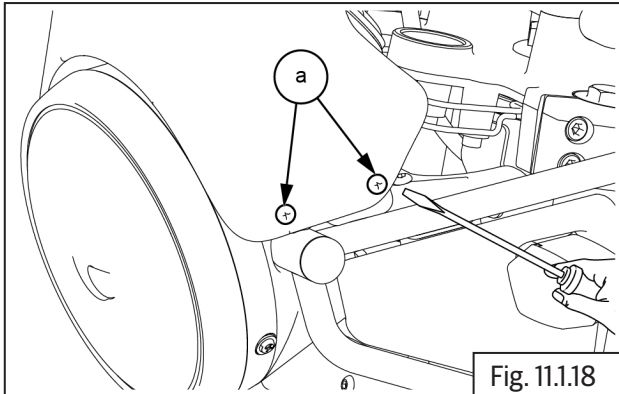

- Remove the 2 Nos. Philip screw **(a)** from RH wind shield.

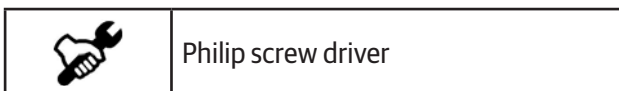
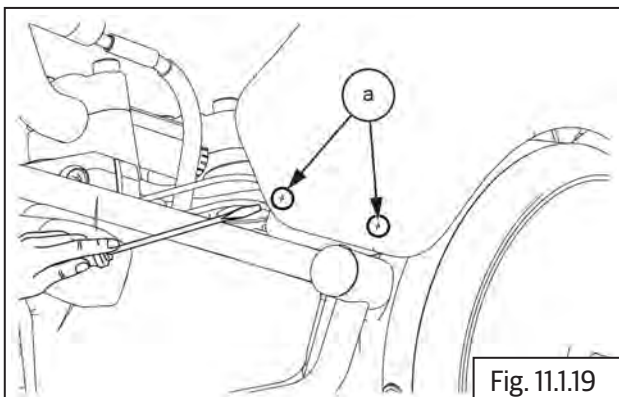

- Gently remove the wind shield **(a)**.

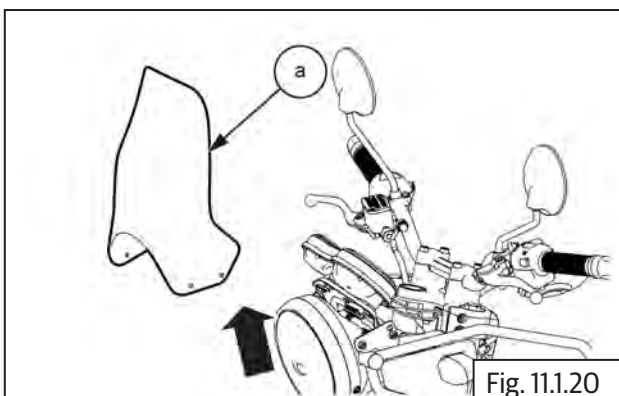

- Remove 3 Nos. Hex socket nut **(M6) (a)** located below Instrument cluster.

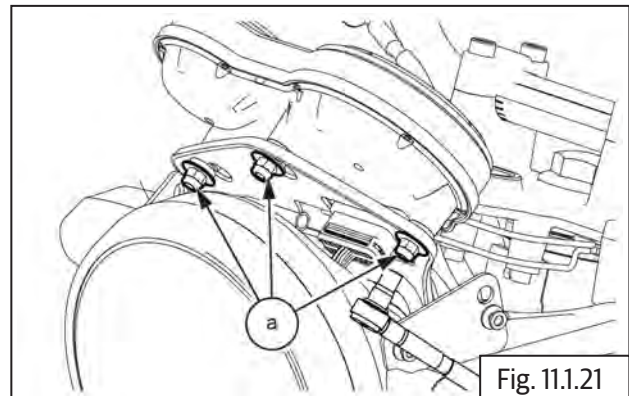

- Disconnect the instrument cluster connector **(a)**.

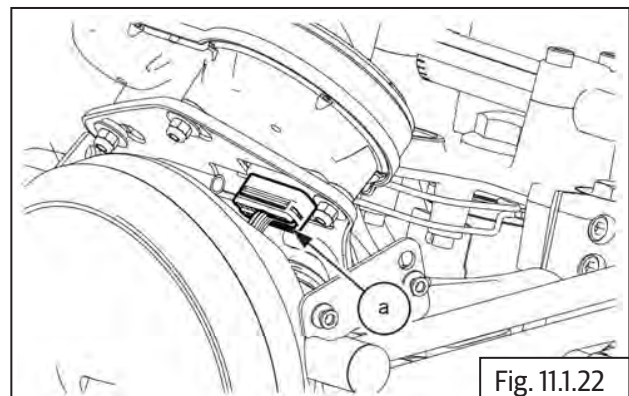

- Gently remove instrument cluster **(a)**.

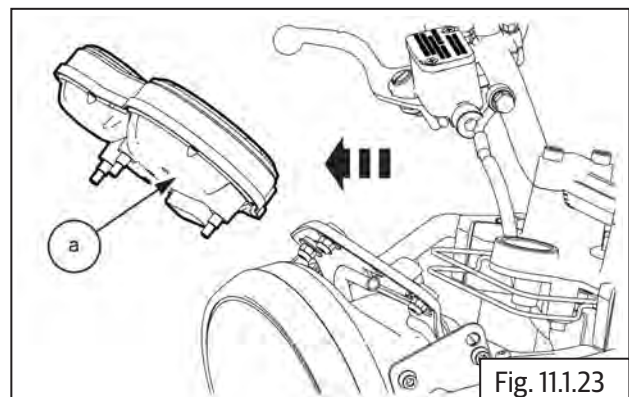

For EURO V model

- Disconnect the navigation unit connector **(a)**.

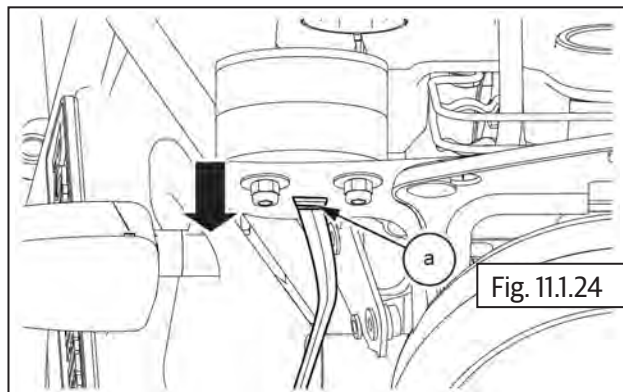

- Remove 2 Nos. Hex socket head bolts **(M5) (a)** along with washer located below cluster bracket on RH side.

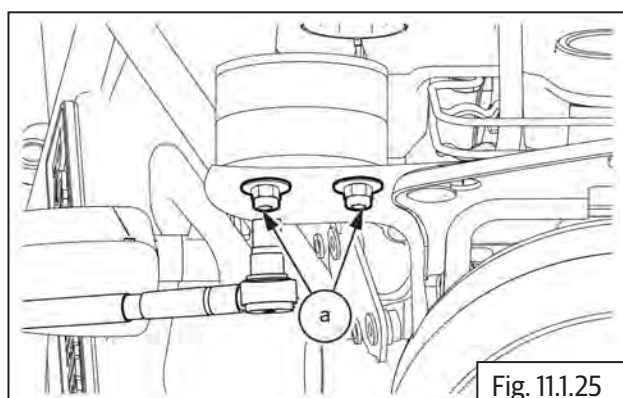

- Gently remove navigation unit **(a)** along with .

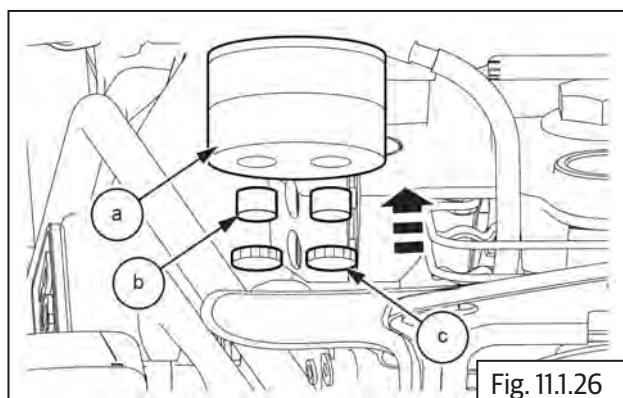

11.3 Tail Lamp Dismantling

11.3.1 Tail Lamp

NOTE

- Handle tail lamp assembly with care. Avoid over tightening of lens screws.

- Loosen and remove 2 Nos. Hex bolts **(a)** from tail lamp.

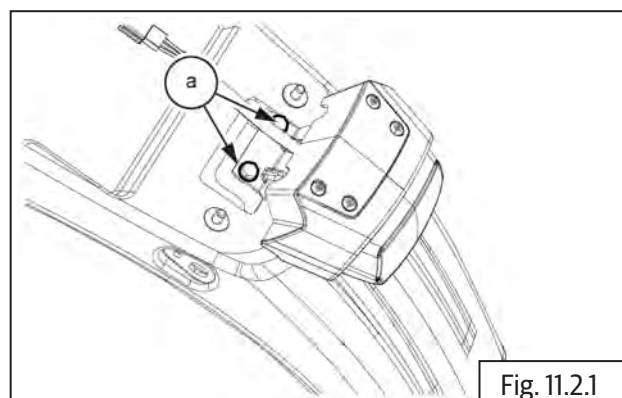

- Gently remove the tail lamp assembly **(a)**.

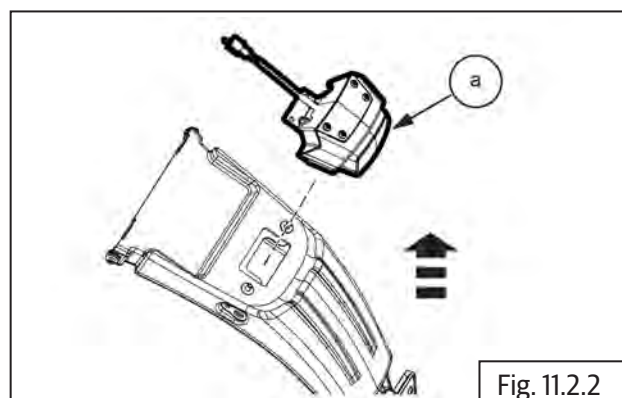

- Remove the 4 Nos. Allen screw (a) from the tail lamp cover.

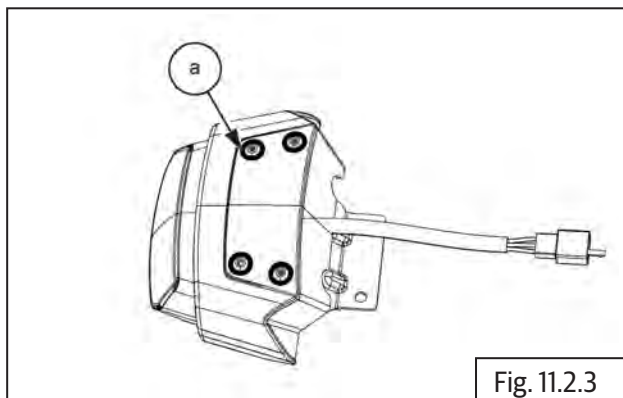

- gently remove the tail lamp cover (a) and bracket (b) from the tail lamp.

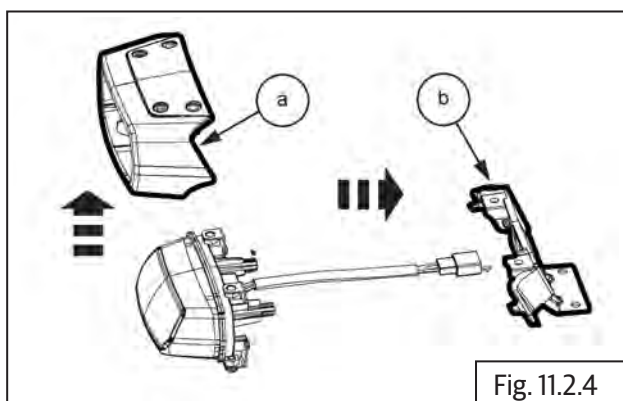

11.4 Brake Lamp Connectors Dismantling

11.4.1 Brake Lamp Connector - Front

- Remove the following parts:
 - Headlamp assembly ([section 11.1.1](#)).
 - Front brake lamp switch ([section 11.1.4](#)).
- Disconnect front brake lamp connector (a).

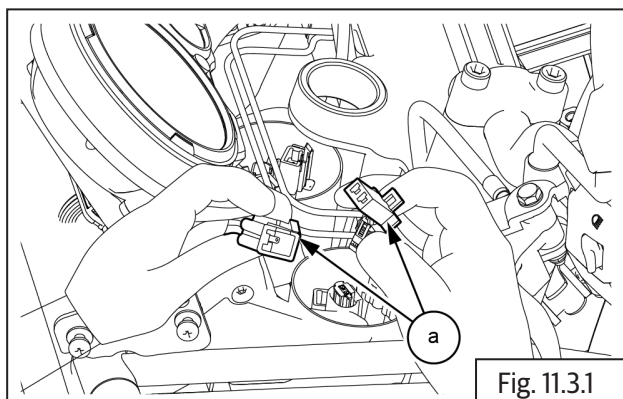

11.5 Trafficators Dismantling

11.5.1 Direction Trafficators - Rear

- Remove the 1 No Hex bolt (a) from the LH side inside.

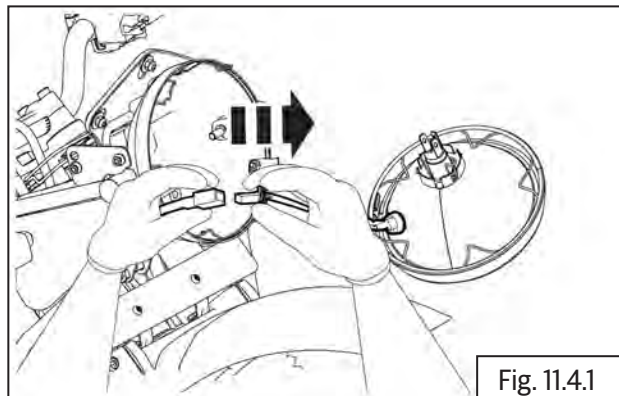

- Remove the 1 No Hex bolt (a) from the LH side inside.

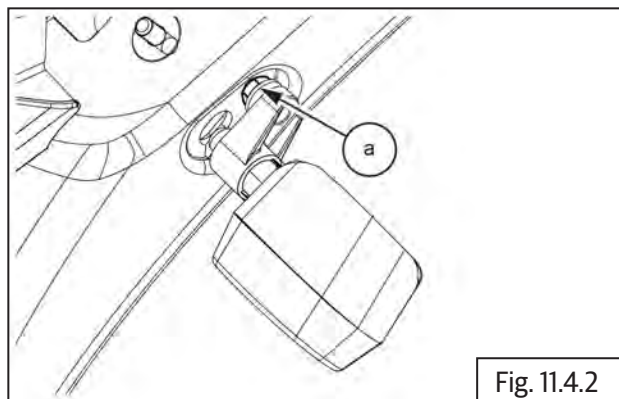

19 mm Ring spanner

11.5.2 Direction Trafficator - Front

- Loosen and remove Hex bolt (a) from RH.

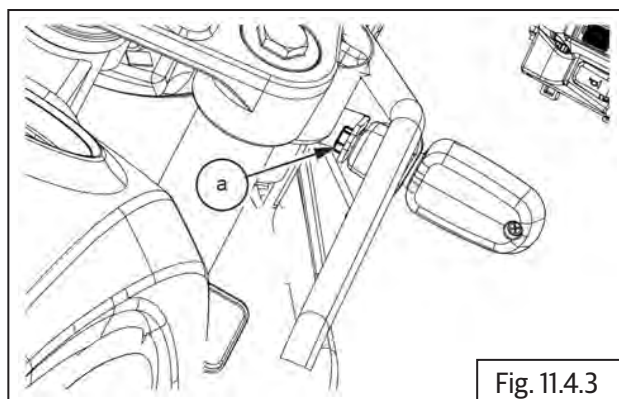

- Gently remove the front RH direction trafficator (**a**)

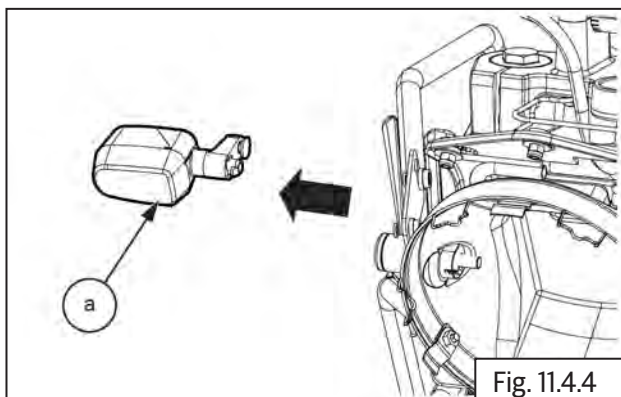

Fig. 11.4.4

- Loosen and remove Hex bolt (**a**) from LH.

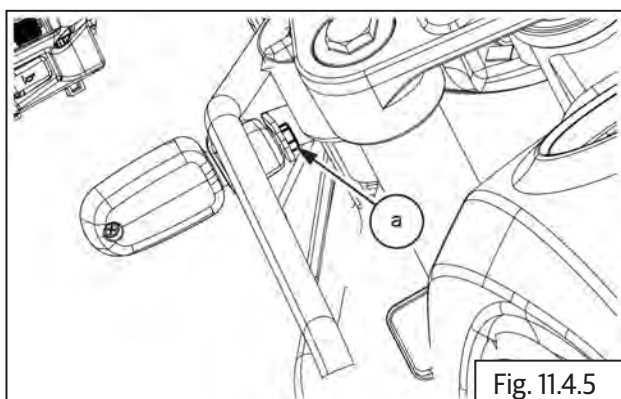

Fig. 11.4.5

- Gently remove the front LH direction trafficator (**a**)

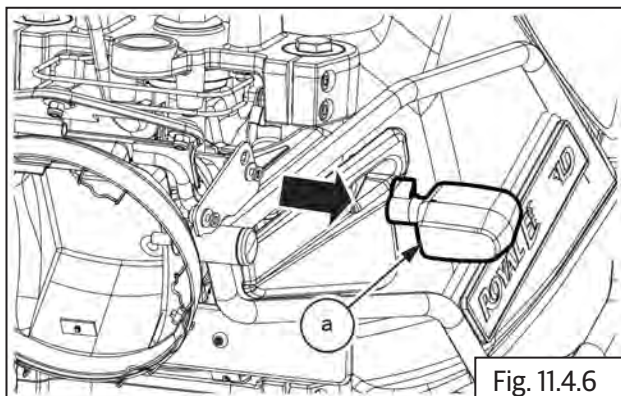

Fig. 11.4.6

11.6 Battery Dismantling

11.6.1 Battery Terminals

- Remove the following parts:
 - Side panel RH ([section 6.7.1](#)).
 - Rider seat ([section 6.7.2](#)).
 - Side panel LH ([section 6.7.4](#)).
- Ensure Ignition and stop switch are in OFF position before disconnecting battery cables.
- Refer general information ([section 1.5.8](#)) for battery connection and disconnection procedure.

NOTE

- If battery lead is difficult to disconnect due to rust or corrosion of battery terminals, pour recommended battery terminal cleaning solution on terminals and then try to disconnect.

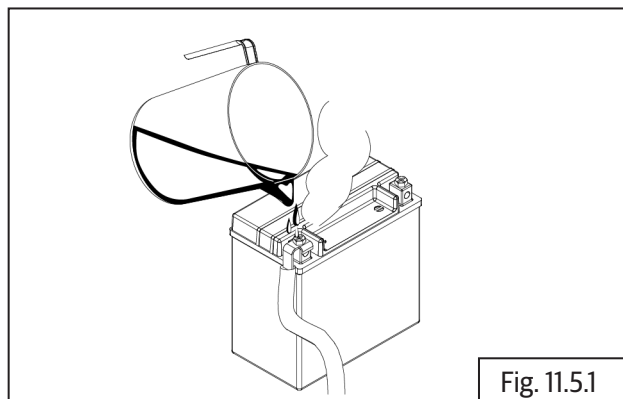

Fig. 11.5.1

- Disconnect battery negative (-) terminal bolt (**a**).

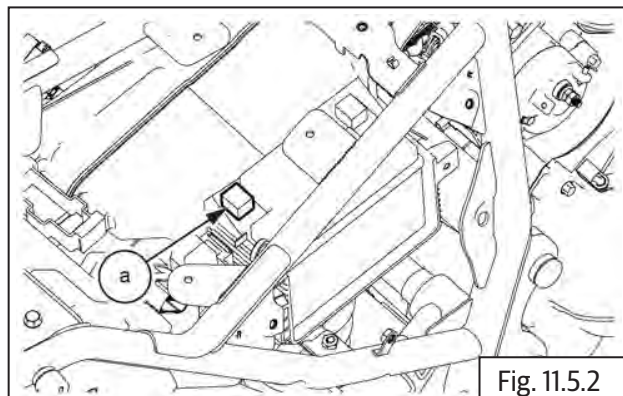

Fig. 11.5.2



10 mm Double end spanner

- Disconnect battery positive (+) terminal **(a)** from battery **(b)**.

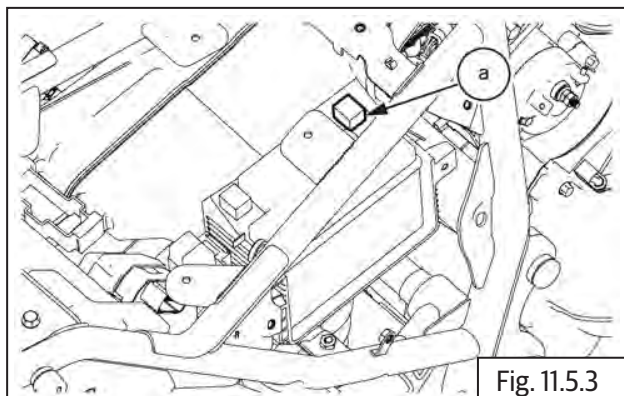

Fig. 11.5.3



10 mm Double end spanner

- Loosen and remove Hex flanged head screw **(M6)** **(a)** from battery strap bracket **(b)**.

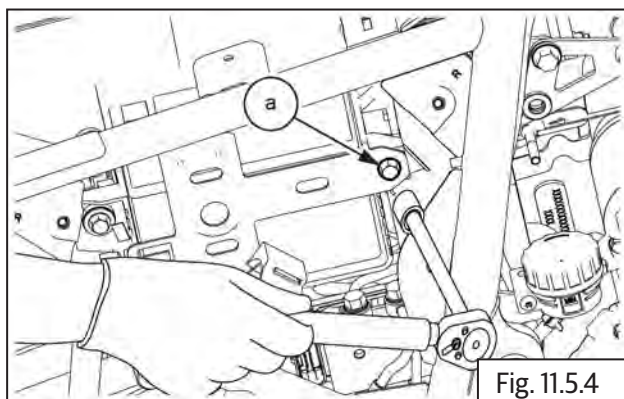

Fig. 11.5.4



5 mm Allen key with Ratchet

- Remove the battery bracket **(a)** from battery tray.

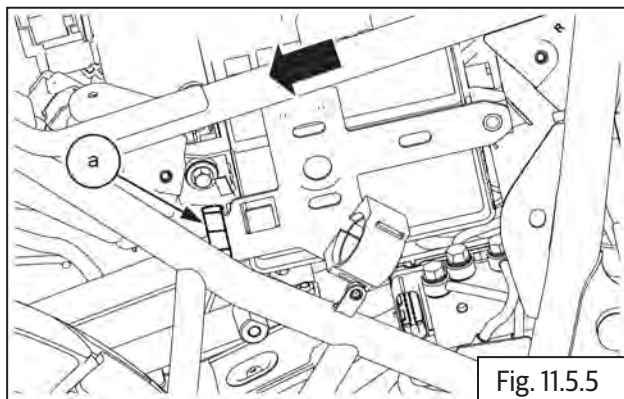

Fig. 11.5.5

- Remove battery **(a)** from tray.

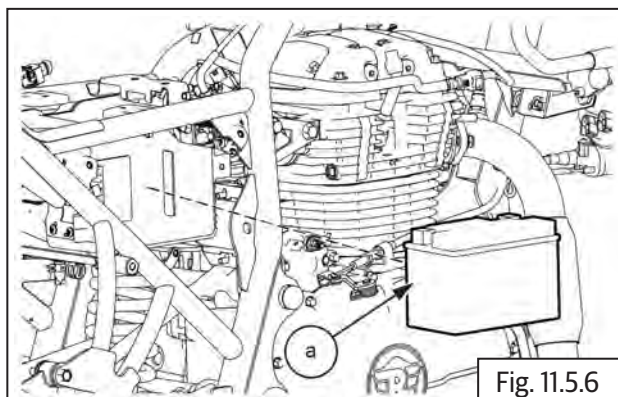

Fig. 11.5.6

11.6.2 RR Unit

⚠ CAUTION

Ensure motorcycle is placed on a flat surface, resting it on center stand/ramp. Support motorcycle with suitable equipment below cradle frame. If necessary

- Locate RR unit **(a)** behind engine.

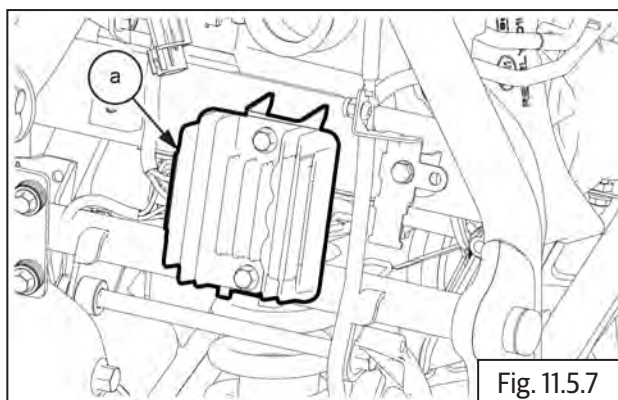

Fig. 11.5.7

- Disconnect RR unit connectors **(a)**.

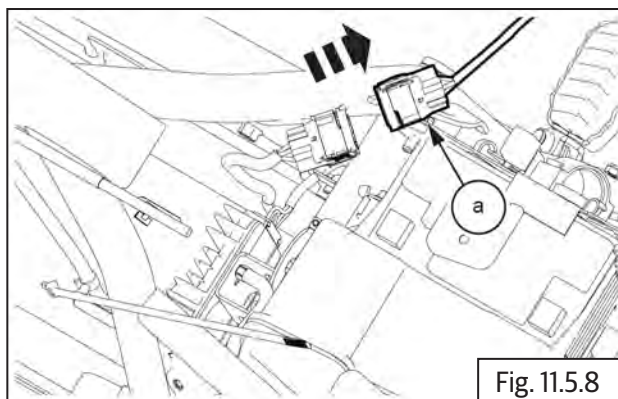
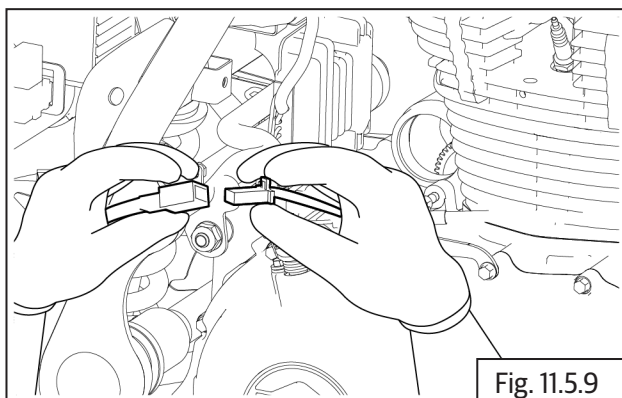
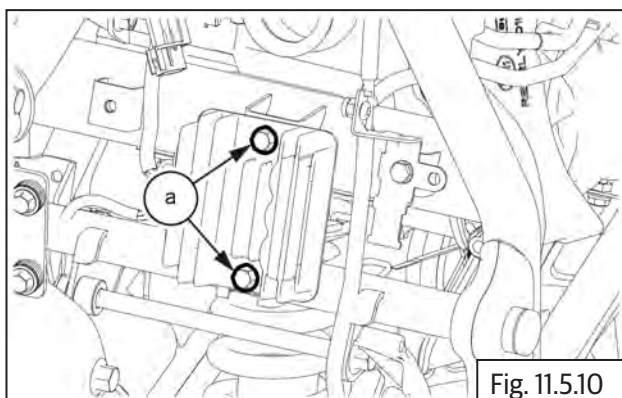

Fig. 11.5.8

- Disconnect the stator coil connector **(a)** from magneto.



- Loosen and remove 2 Nos. Hex flanged bolts **(M6)** **(a)** along with washer.



- Gently slide RR unit **(a)** out from frame.

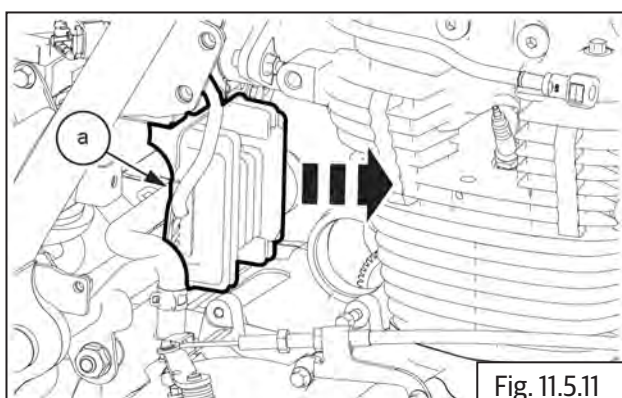

11.7 Inspection

- Inspect connector pins for any bends, corruptions and damages.
- Inspect headlamp holder for any scratches, rust, cracks and damages. Replace if it is defective.
- Inspect and replace reflector if it has any damages and/or distraction.
- Inspect if wire clips are loosened and tighten appropriately.
- Inspect if headlamp holder bolt is loosened and tighten appropriately.
- Inspect the bulb filament for any damages and replace.

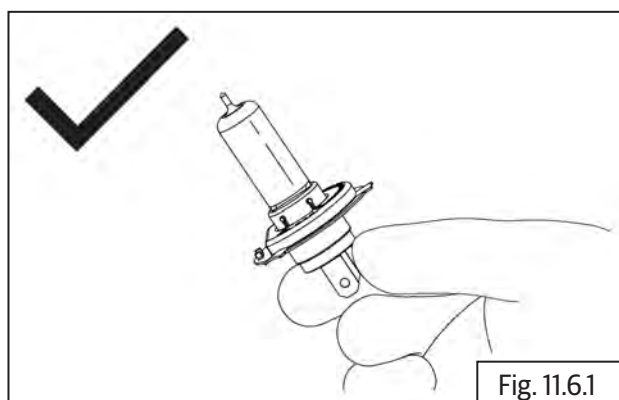

Battery

- Check battery for any damages.
- Check the battery terminals for sulfating, corrosion or damages.
- Test voltage level. It should be 12.8V to 13.2V approximately.

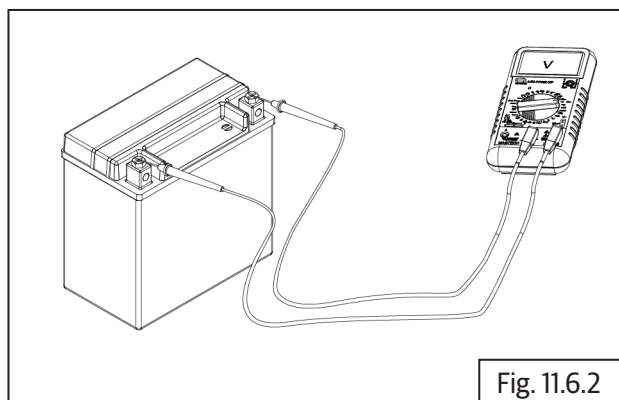

Windshield

- Check rubber nut while assemble & dismantle the Windshield.
- Ensure the rubber nut is not damaged before fitment. Replace if damaged.

11.8 Assembly

11.9 Battery Assembly

11.9.1 RR unit Assembly

- Gently slide the RR unit **(a)** behind engine.

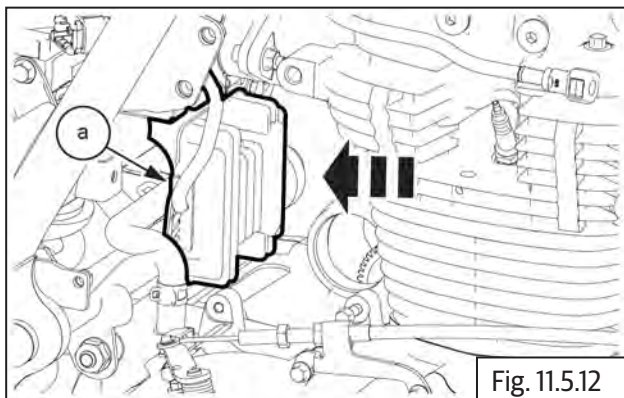

- Insert and tighten 2 Nos. Hex flanged bolts **(M6)** **(a)** along with washer to fix RR unit.

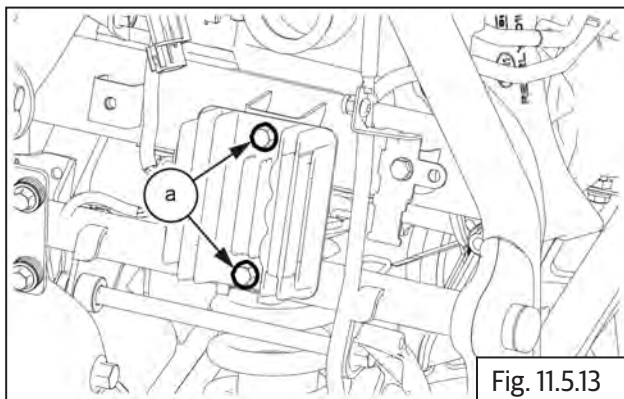

	10 mm Socket with Ratchet
Torque	8-12 N-m/0.8-1.2 kgf-m

- Connect the stator coil connector **(a)** to magneto.

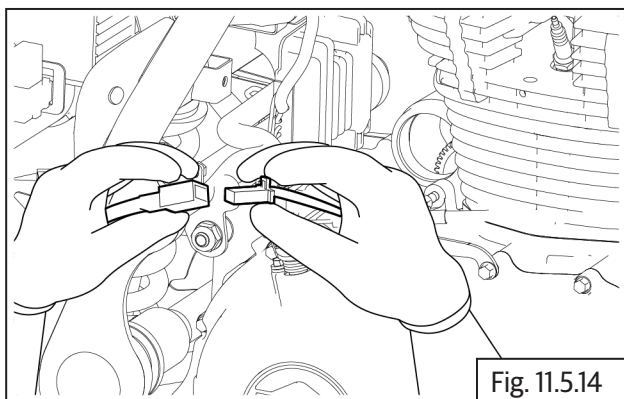

- Connect RR unit connector **(a)** into wiring harness and ensure they are locked properly.

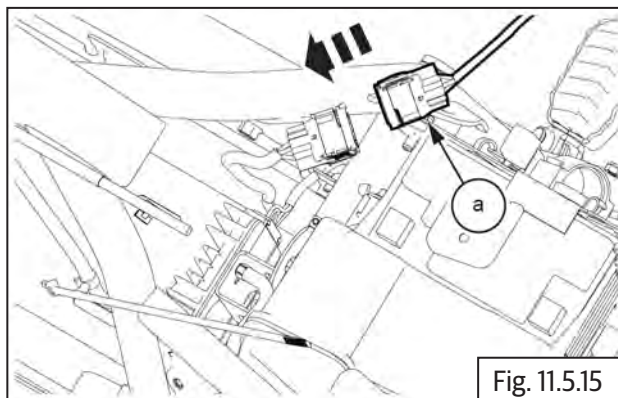

11.9.2 Battery Assembly

- Install battery **(a)** into tray **(b)**.

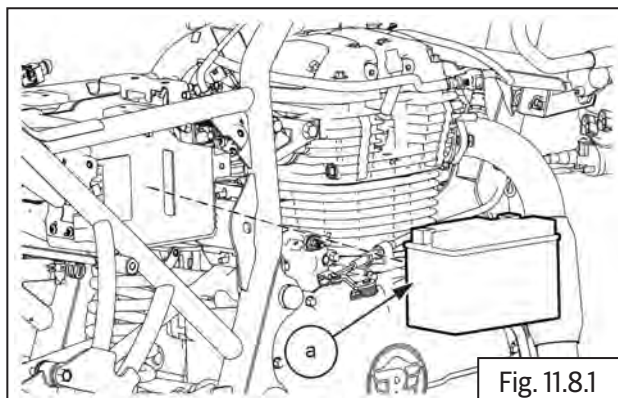

- Place battery bracket **(a)** onto battery tray **(b)**.

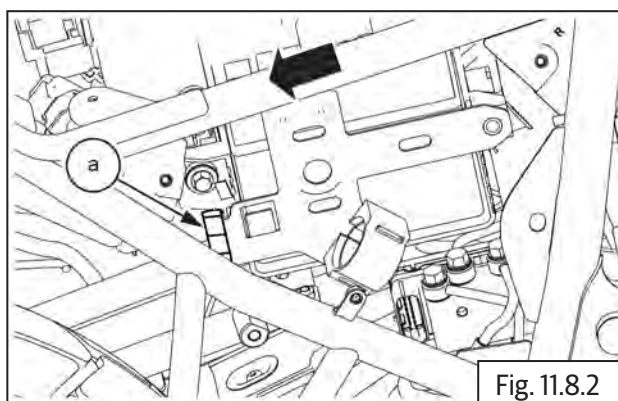

- Locate and tighten flanged head screw **(M6) (a)** onto battery bracket **(b)**.

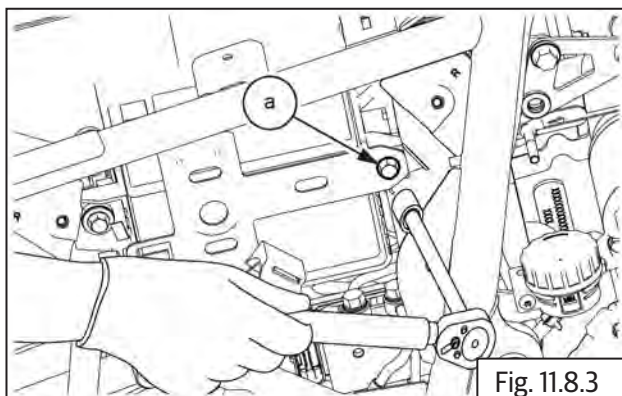

	5 mm Allen key with Ratchet
Torque	10 N-m/1.01 kgf-m

11.9.3 Battery Terminals

- Connect battery positive (+) terminal **(a)** and tighten Hex head bolt **(M6) (b)**.

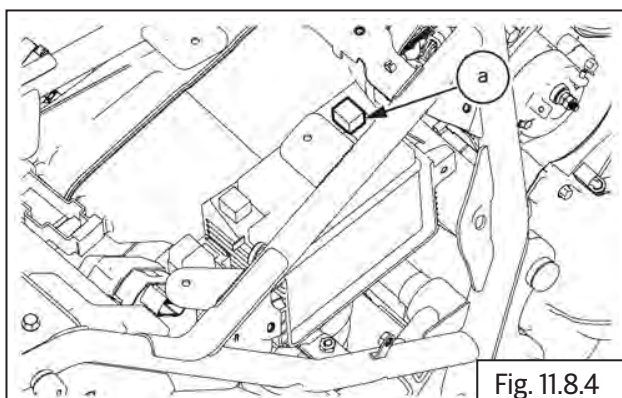

	10 mm Double end spanner
--	--------------------------

- Connect battery negative (-) terminal **(a)** and tighten Hex head bolt **(M6)**.

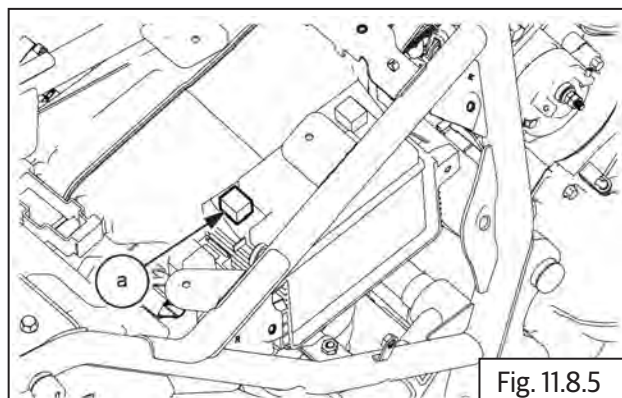

	10 mm Double end spanner
--	--------------------------

- Clean and apply recommended agents on battery terminals.

11.10 Trafficators Assembly

11.10.1 Direction Trafficator - Front

- Gently align the front RH direction trafficator **(a)** on the bracket.

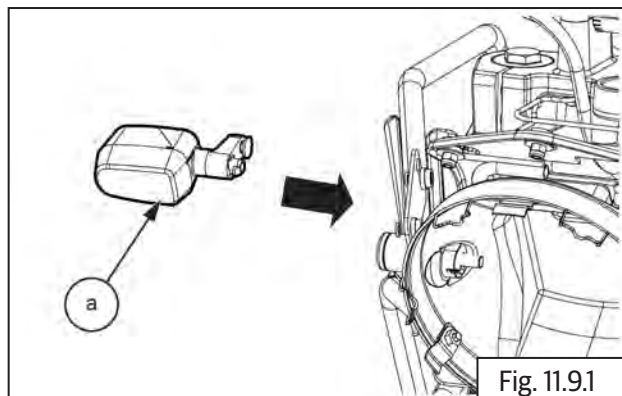

- Install the RH direction trafficator using the hex bolt **(a)**.

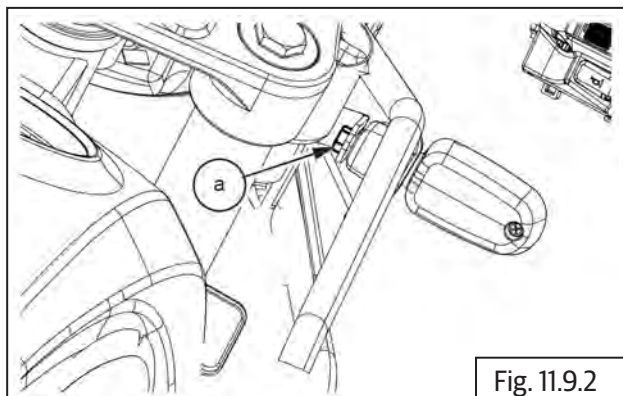

Fig. 11.9.2

- Gently align the front LH direction trafficator **(a)** on the bracket.

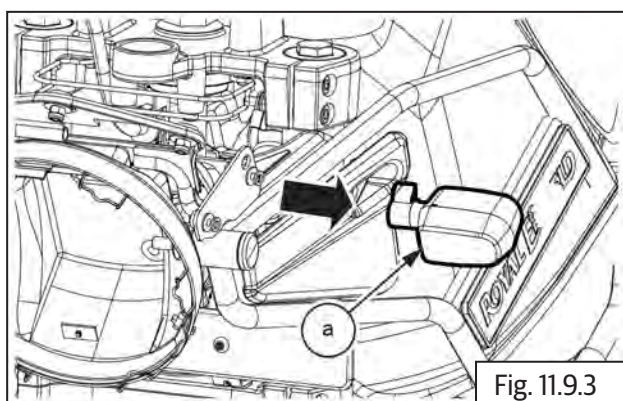

Fig. 11.9.3

- Install the LH direction trafficator using the hex bolt **(a)**.

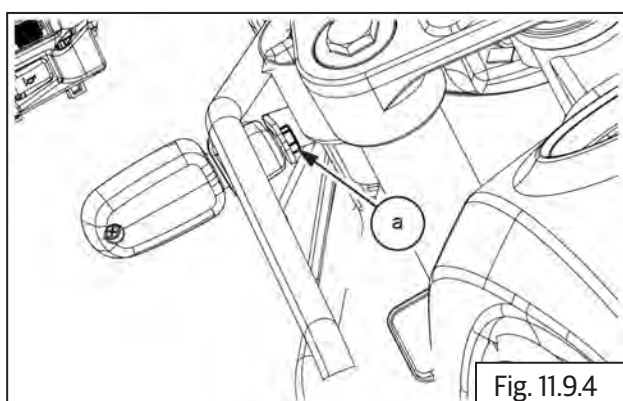

Fig. 11.9.4

NOTE

- After assembling headlamp assembly, check light operation.

11.10.2 Direction Trafficators - Rear

- Gently instal the RH direction trafficator **(a)** on the bracket..

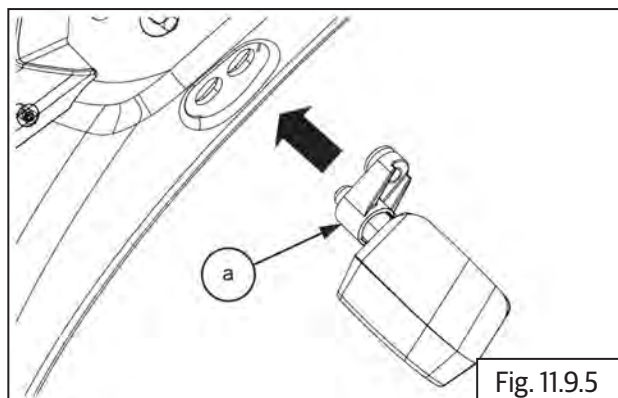

Fig. 11.9.5

- Install the RH direction trafficator using a hex nut **(a)**.

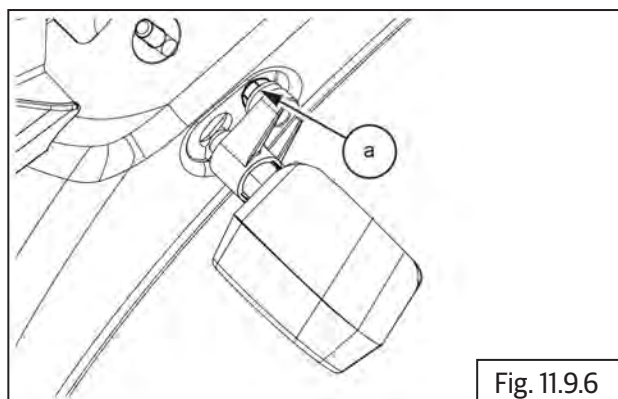

Fig. 11.9.6

- Gently instal the LH direction trafficator **(a)** on the bracket..

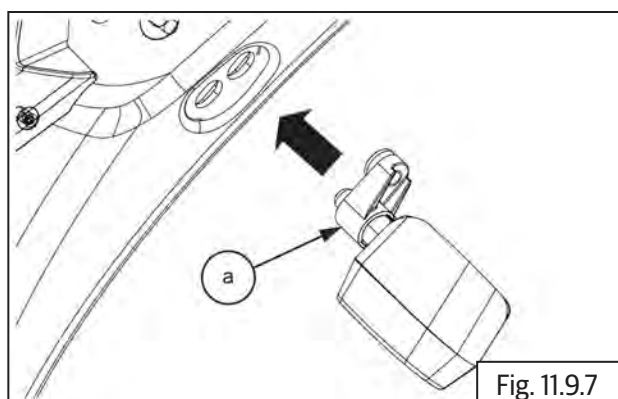
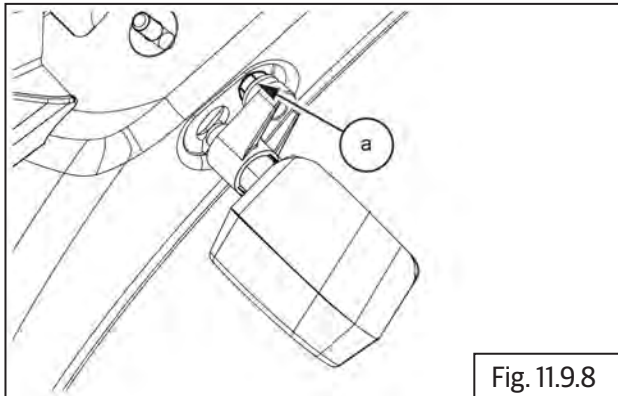

Fig. 11.9.7

- Install the LH direction trafficator using a hex nut **(a)**.



11.11 Brake Lamp Connectors Assembly

11.11.1 Brake Lamp Connector - Front

- Connect front brake lamp connector **(a)**.

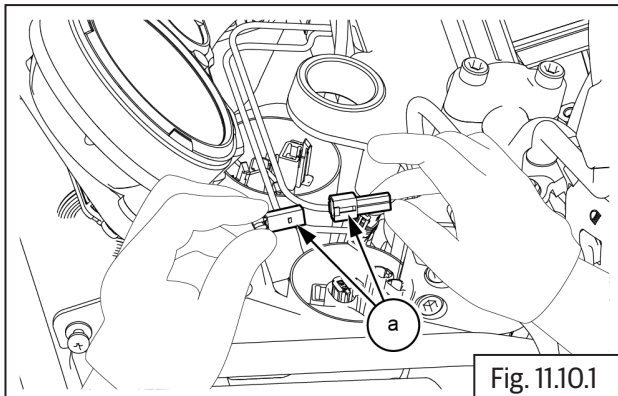

- After assembling front brake switch. Check front brake operation at Tail lamp

11.12 Tail Lamp Assembly

11.12.1 Tail Lamp

- Align the tail lamp cover **(a)** and bracket **(b)** over the tail lamp.

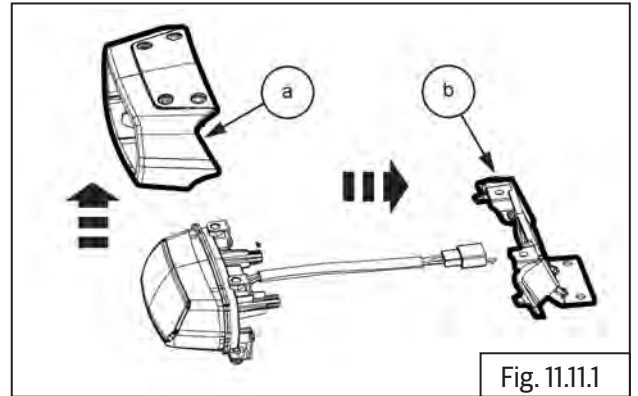

- Install the tail lamp cover using 4 Nos. Allen screw **(a)**.

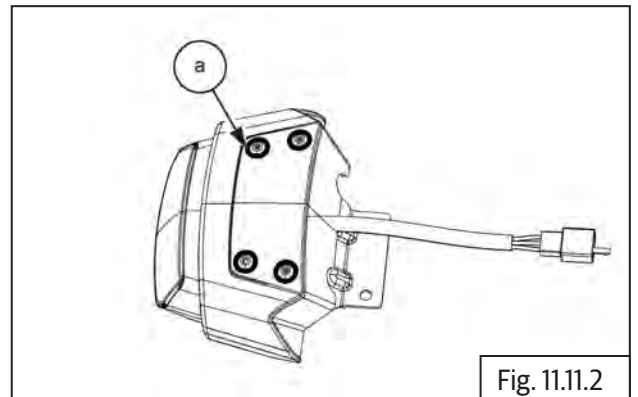

- Locate and tighten 2 Nos. Hex bolts **(a)** into tail lamp.

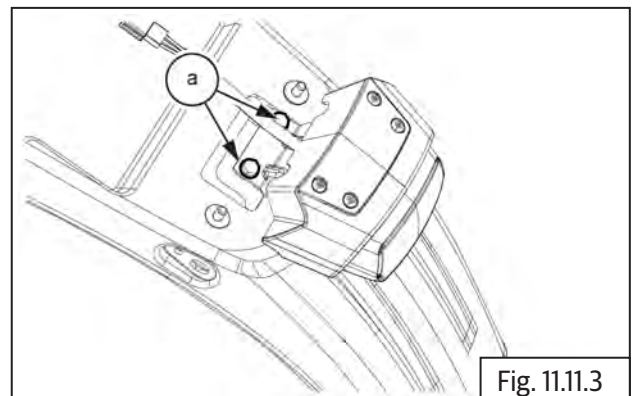

4 mm Socket with Ratchet

NOTE

- After assembling tail lamp assembly, check tail lamp operation & brake light operation.

11.12.2 Cluster Assembly

For EURO V model

- Install the navigation unit using 2 Nos. Hex socket Head bolt (**M5**) along with washer on the Bracket.

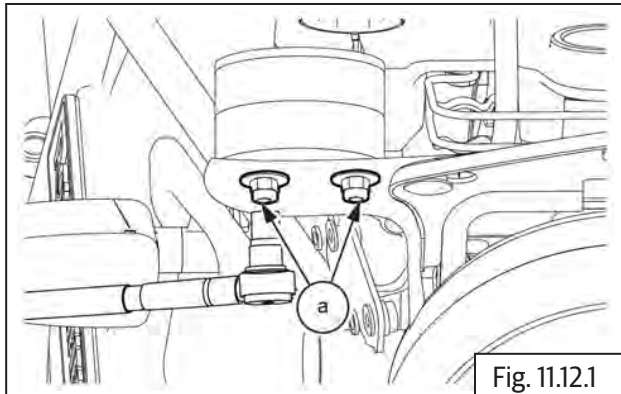

	5 mm Hex socket with Ratchet
Torque	3 N-m/0.3 kgf-m

- Connect the connector (**a**) to the navigation unit.

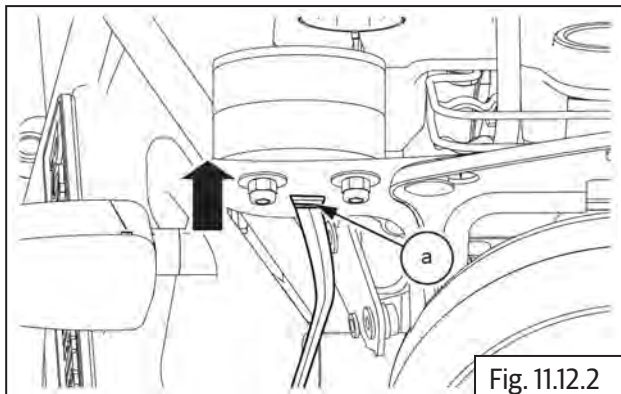

- Align the instrument cluster (**a**) over the cluster bracket..

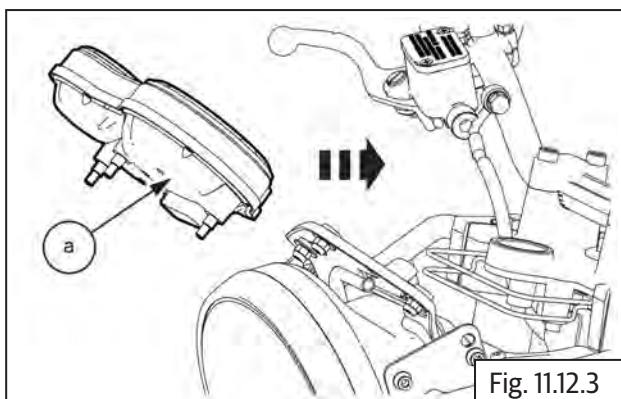

- Connect the instrument cluster connector (**a**).

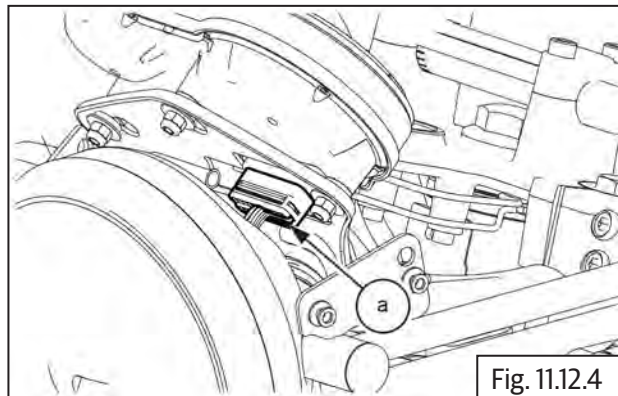

- Install instrument cluster using 3 Nos. Hex nut **M6** (**a**) along with washer.

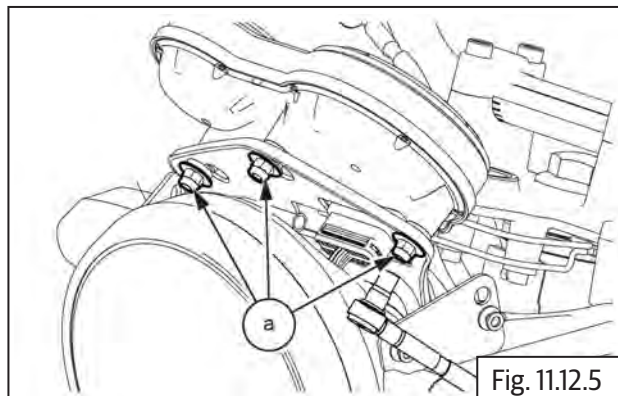

	5 mm Hex socket with Ratchet
Torque	10 N-m/1.01 kgf-m

11.11.2 Connectors and Sensors into Headlamp Housing

- Locate and connect ignition switch connector (**a**). Ensure it is properly seated/locked.

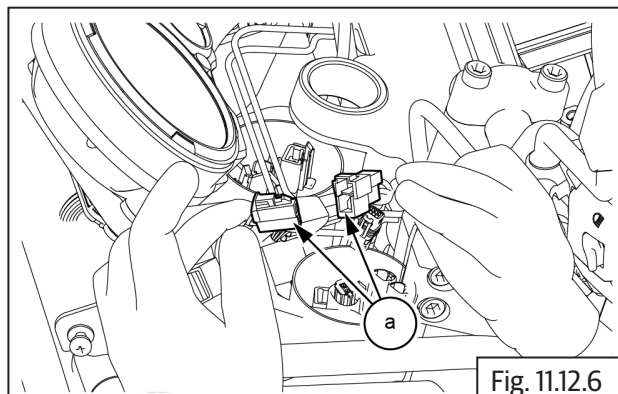

- Locate and connect RH trafficator sensor connector **(a)**. Ensure it is properly seated/locked.

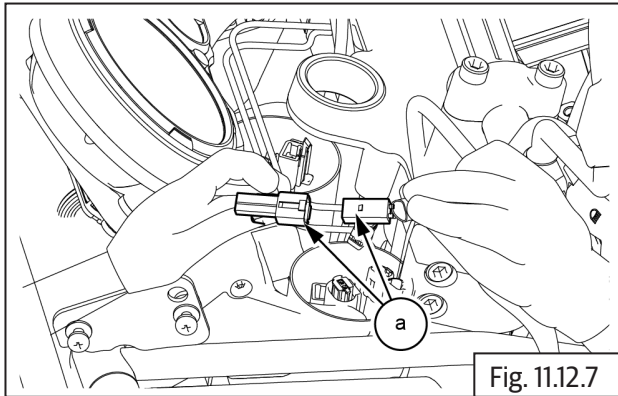

Fig. 11.12.7

- Locate and connect RH module connector **(a)**. Ensure it is properly seated/locked.

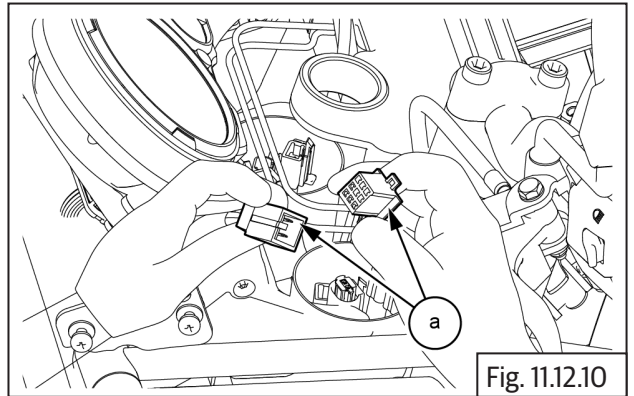

Fig. 11.12.10

- Depress and lock LH trafficator sensor connector **(a)**. Ensure it is properly seated/locked.

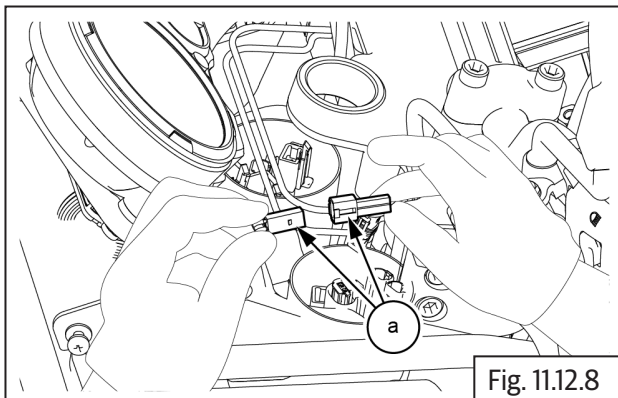

Fig. 11.12.8

- Connect front brake lamp switch connector **(a)**. Ensure it is properly seated/locked.

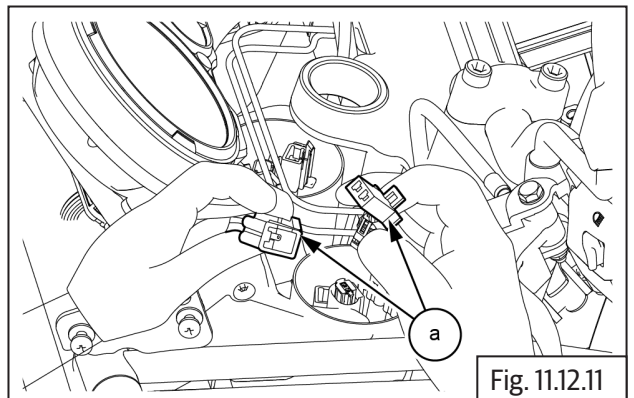

Fig. 11.12.11

- Locate and connect wheel speed sensor connector **(a)**. Ensure it is properly seated/locked.

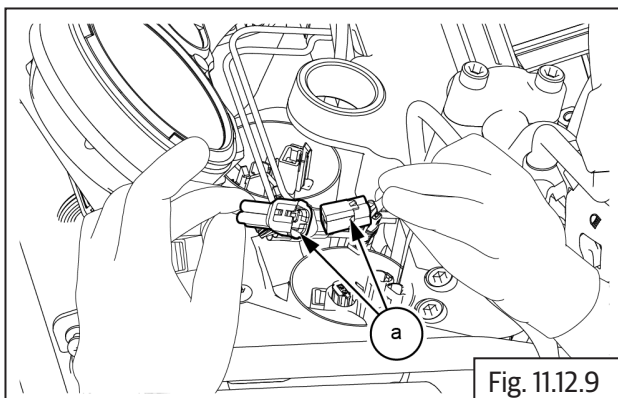

Fig. 11.12.9

- Connect clutch switch connector **(a)**. Ensure it is properly seated/locked.

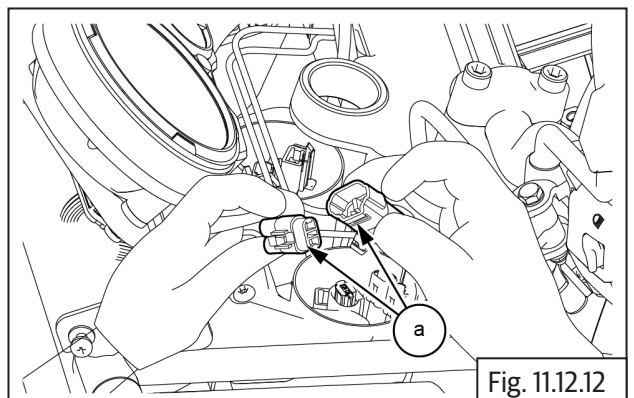
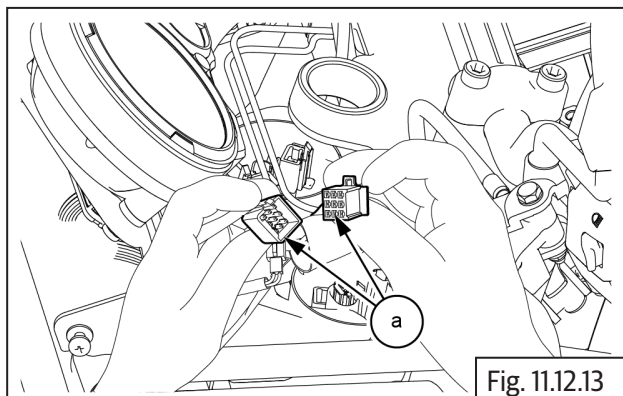

Fig. 11.12.12

- Locate and connect LH module connector **(a)** into headlamp housing. Ensure it is properly seated/locked.



11.12.1 Headlamp Bulb into Reflector

⚠ CAUTION

Do not touch glass of bulb. Any strains or finger prints will affect the luminosity.

Ensure pointed tip of bulb does not get damaged

Whenever handling the bulb, hold it firmly at terminal end and not at glass end.

- Gently locate headlamp bulb **(a)** into reflector and install wire clip **(b)** onto reflector **(c)**.

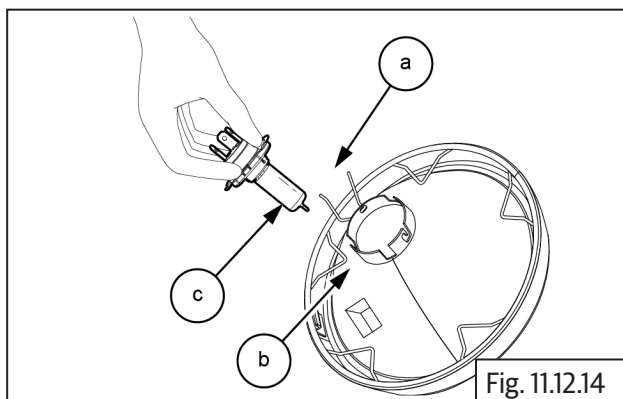

- Depress wire clip **(a)** and lock into slot **(b)** in headlamp reflector.

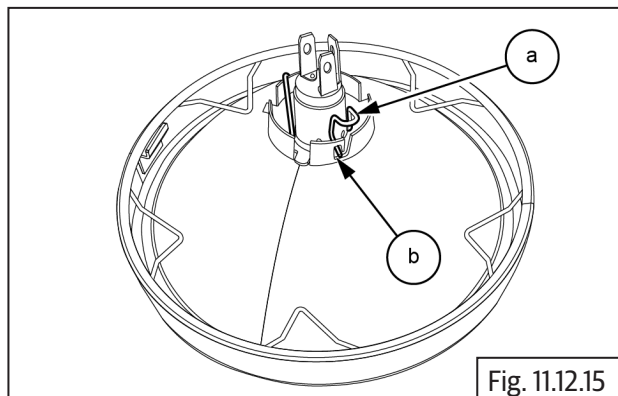

11.12.2 Pilot Bulb into Reflector

- Gently depress bulb **(a)** to holder and turn clockwise to fix bulb into holder **(b)**.

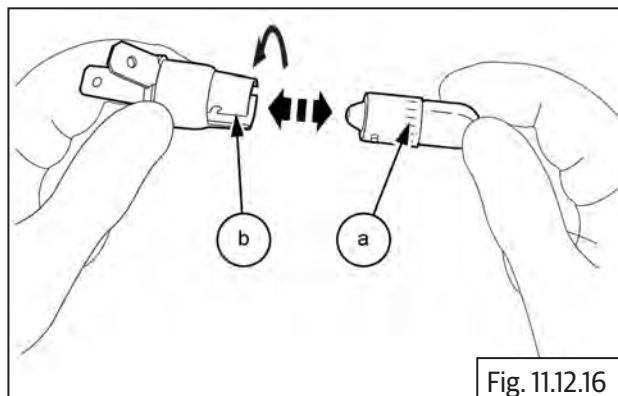

11.11.3 Headlamp Reflector into Housing

- Connect pilot bulb connector **(a)** carefully.

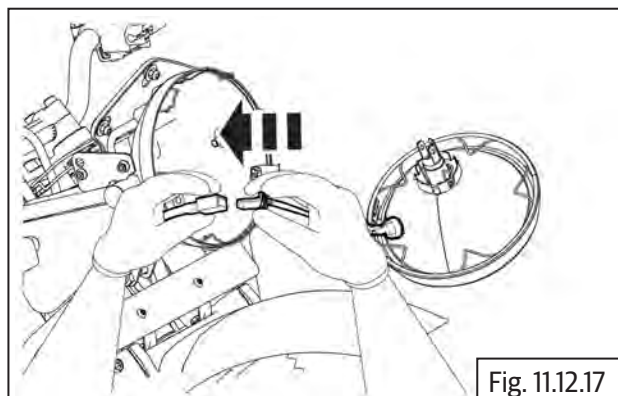

- Hold headlamp carefully and connect headlamp connector **(a)** into headlamp bulb.

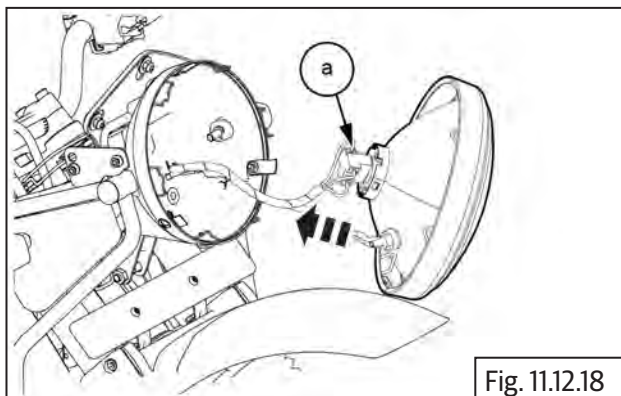

Fig. 11.12.18

⚠ CAUTION

Support the headlamp assembly properly and carefully.

- Carefully assemble reflector **(b)** along with front rim **(a)** into housing **(c)**.

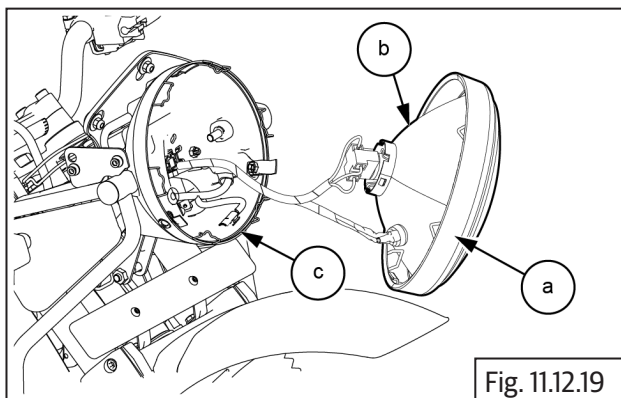

Fig. 11.12.19

- Insert and tighten 2 No. Phillips screw **(a)** on Both the sides of the headlamp.

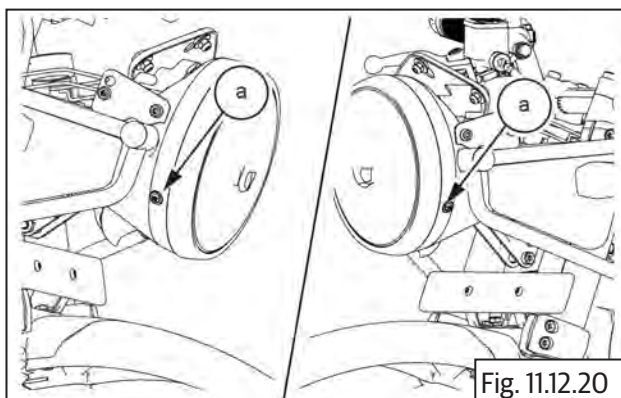

Fig. 11.12.20



Phillips screw driver

- Inspect and test all electrical functions after completing assembly.

ADDON SERVICE MANUAL HIMALAYAN -2021

PERIODIC MAINTENANCE SCHEDULE (PMS)

Periodical Maintenance Schedule (PMS)

The maintenance schedule detailed here will help you maintain your Himalayan motorcycle meticulously and to get a long trouble free service. The schedule provided herein is based upon average 400CC riding conditions and indicates at which regular inspections, adjustments, replacements and lubrications frequency are to be carried out. The frequency of the maintenance must be shortened depending upon the severity of the driving condition or if the motorcycle is used in a very dusty environment. Contact the nearest Royal Enfield Authorized Dealer/Service Center for expert advice and to carry out the required maintenance.

Sl. No.	Description	Periodic Maintenance										
		0.5	5	10	15	20	25	30	35	40	45	50
	km (x 1000)	0.3	3	6	9	12	15	18	21	25	28	31
	Miles (x 1000)	1.5	6	12	18	24	30	36	42	48	54	60
	Months (Euro V)											
1	Engine oil (Level check / Replace) (#)	R	I	R	I	R	I	R	I	R	I	R
		Check level at every 1000 Kms or earlier as required										
2	Engine oil filter element (#)	R		R		R		R		R		R
3	Engine oil strainer on crankcase LH (#)	I&A	I&A	I&A	I&A	I&A	I&A	I&A	I&A	I&A	I&A	I&A
4	Inlet / Exhaust Tappet setting	I&A	I&A	I&A	I&A	I&A	I&A	I&A	I&A	I&A	I&A	I&A
5	Rubber hose, Inlet manifold Adapter	I	I	I	I	I	I	I	I	R	I	I
6	Oil cooler inlet & outlet pipes *	I	I	I	I	I	I	I	I	I	I	I
7	Spark plug	C&A	C&A	C&A	C&A	C&A	C&A	C&A	C&A	C&A	C&A	C&A
8	HT leads for crack	I	I	I	I	I	I	I	I	I	I	I
9	Fuel Hose & Clip	I	I	I	I	I	I	I	I	I	I	I
10	Fuel Pump (under tank) Mounting	Check for screw tightness in all services										
11	Air filter element	C	C	R	C	R	C	R	C	R	C	R
		Clean/ Replace more frequently if motorcycle always used in dusty / off Road conditions										
12	Accelerator Cable	I&A	I&A	I&A	I&A	I/A/R	I/A/R	I/A/R	I/A/R	I/A/R	I/A/R	I/A/R
13	Rubber Hose, Air filter to Throttle body	I	I	I	I	I	I	I	I	R	I	I
14	PAV pipes & Hose clip	I	I	I	I	I	I	I	I	R	I	I
15	Evaporative Emission Equipment rubber hoses	I	I	I	I	I	I	I	I	R	I	I
I - Inspect (Clean and lubricate if necessary) A - Adjust (If Necessary) L - Lubricate R - Replace C - Clean T- Re-tighten (#) - After First service, Engine oil and Engine oil filter replacement is a mandatory at every 12 months even the vehicle has not covered the specified kms.												
16	Throttle body- Cleaning spray	Carbo cleaner / carb click / or Fuel line cleaner spray every 5000 Km or 6 months whichever is earlier										

Sl. No.	Description	Periodic Maintenance										
		0.5	5	10	15	20	25	30	35	40	45	50
	km (x 1000)	0.3	3	6	9	12	15	18	21	24	27	30
	Miles (x 1000)	1.5	6	12	18	24	30	36	42	48	54	60
	Months	I&A	I&A	I&A	I&A	I&A	I&A	I&A	I&A	I&A	I&A	I&A
17	Clutch Cable	I&A	I&A	I&A	I&A	I&A	I&A	I&A	I&A	I&A	I&A	I&A
18	Clutch free play	Adjust every 1000 Kms or earlier as required										
19	Clutch no slippage	I	I	I	I	I	I	I	I	I	I	I
20	Steering head bearings #	I&A	Inspect, adjust & lubricate for every 5000 km or earlier as required. Replace if necessary									
21	Front Fork oil / leak	I	I	I	I	R	I	I	I	R	I	I
22	Rear Wheel Drive Chain (#)	I&A	Clean, Lubricate & Adjust every 1000 Kms or earlier as required									
23	Battery terminals (apply petroleum jelly)	C	C	C	C	C	C	C	C	C	C	C
24	Earth wire eyelet Tightness			I		I		I		I		I
25	Hydraulic Brake Fluid - Front & Rear (#)	I	I	I	I	R	I	I	I	R	I	I
26	Hydraulic brake hose & Washers - Front & Rear (#)	I	I	I	I	I	I	I	I	I	I	I
27	Brake Pads - Front & Rear (#)	I	I	I	I	I	I	I	I	I	I	I
28	Tyre wear pattern (Front & Rear) (#)	I	I	I	I	I	I	I	I	I	I	I
29	Spokes tightness / Wheel rim run out front & rear (#)	I	I	I	I	I	I	I	I	I	I	I
30	Front & Rear wheel bearings for play (#)	I	I	I	I	I	I&R	I	I	I	I	I&R
31	Swingarm Pivot Bearings (#)	I	Inspect & If required lubricate for every 5000 km or earlier as required. Replace if necessary									
32	Rear Suspension Linkages (#)	I	Inspect & If required lubricate for every 5000 km or earlier as required. Replace if necessary									
33	Rear Brake Pedal Pivot	L	L	L	L	L	L	L	L	L	L	L
34	Rear Brake Pedal free play	Adjust every 1000 Kms or earlier as required										
35	Rear wheel cush rubbers (#)	I	I	I	I	I&R	I&R	I&R	I&R	I&R	I&R	I&R
36	All Mounting Fasteners in vehicle for tightness (#)	I&T	I&T	I&T	I&T	I&T	I&T	I&T	I&T	I&T	I&T	I&T
37	Hand levers, Centre stand, side stand, Rider & Pillion foot rest Pivots & Gear shift Levers (#)	Lubricate every 1000 Kms or earlier as required										
38	Cam Chain / Chain Pads / Auto chain Tensioner	I	I	I	I	I	I	I	I	I	I	I&R
39	Starter motor & Starter relay connections	I	I	I	I	I	I	I	I	I	I	I
40	Side stand switch operation	I	I	I	I	I	I	I	I	I	I	I
I - Inspect (Clean and lubricate if necessary) A - Adjust (If Necessary) L - Lubricate R - Replace C - Clean T - Re-tighten (#) - After First service, Engine oil and Engine oil filter replacement is a mandatory at every 12 months even the vehicle has not covered the specified kms.												

NOTE

- For Maintenance after 50,000 kms, Please repeat the same frequency specified above, in consultation with a Royal Enfield Authorized Dealer/Service Center.

EMS ADAPTATION PROCEDURE

The following procedure to be followed when if any change in the EMS sensors or fuel type

Step 1 - Check for Engine Oil Temperature (EOT) at start is less than **40 °C**.

Step 2 - Allow the engine to idle and leave it undisturbed till the Engine Oil Temperature reaches 115 °C. (Time required for the EOT to reach **115 °C** will be 30 minutes approximately)

Step 3 - Once Engine Oil Temperature reaches **115 °C**, turn "**OFF**" the ignition key and **DO NOT** turn it back ON for the next 30 seconds.

ENGINE

1.1. Throttle Body Removal

- Loosen and remove 1 No **(M5)** allen bolt **(a)** holding the clamp **(c)**
- Gently pull out the throttle body **(b)** along with rubber manifold.

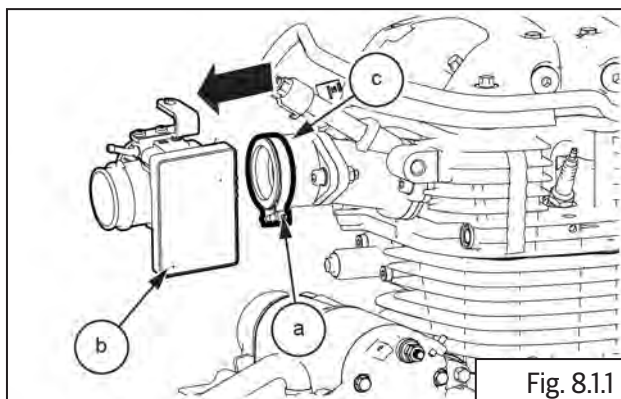

4 mm Allen socket with Ratchet

1.2 Throttle Body Installation

- Gently locate the throttle body **(b)** along with the rubber manifold on to the clamp **(c)**.
- Install the throttle body **(b)** using 1 No, allen bolt **(a)** **(M5)**.

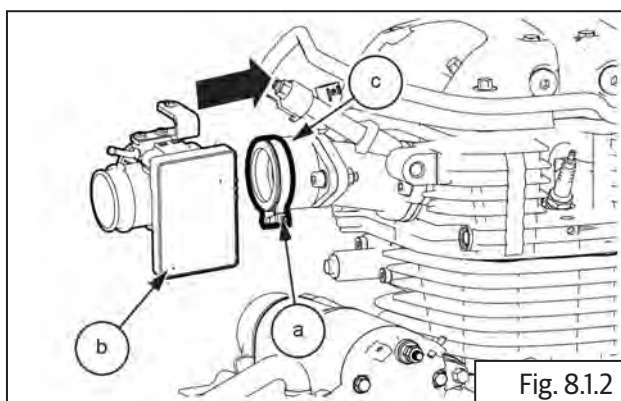

4 mm Allen socket with Ratchet

EVAPORATIVE (EVAP) EMISSION CONTROL SYSTEM

2.1. Canister Removal

- Remove the rider seat.
- Remove the rear mud guard.
- Disconnect the inlet hose, outlet hose **(a)** and drain hose from the canister.

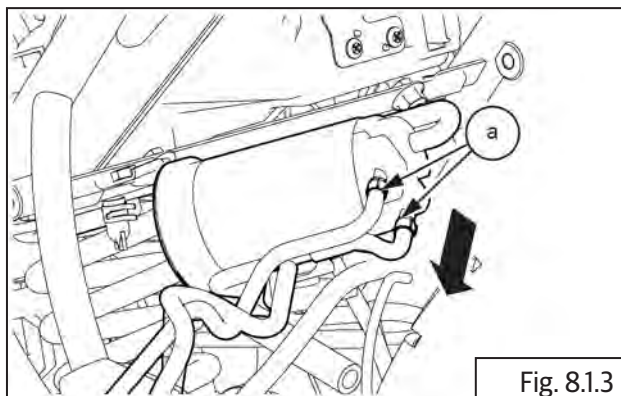

- Loosen and remove the hex bolt (a) from the canister.

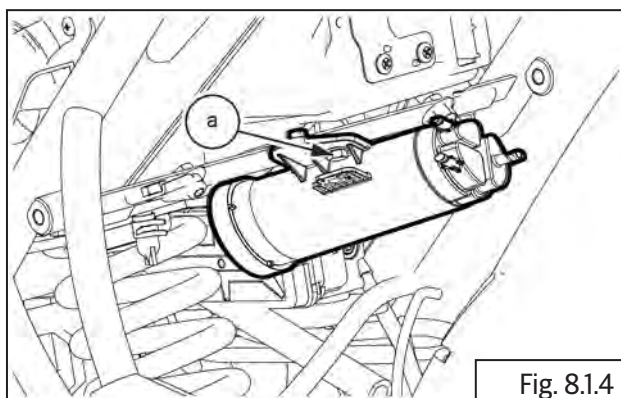

- Remove the canister **(a)** by removing the 1 No. Hex bolt.

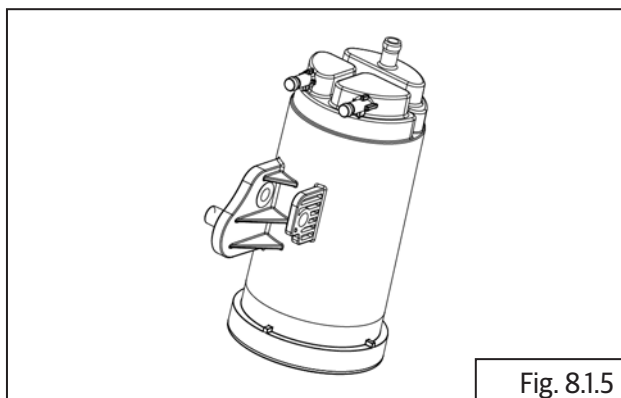

2.2 Canister Installation

- Install the canister on the bracket using the 1 No. Hex bolt **(a)**.

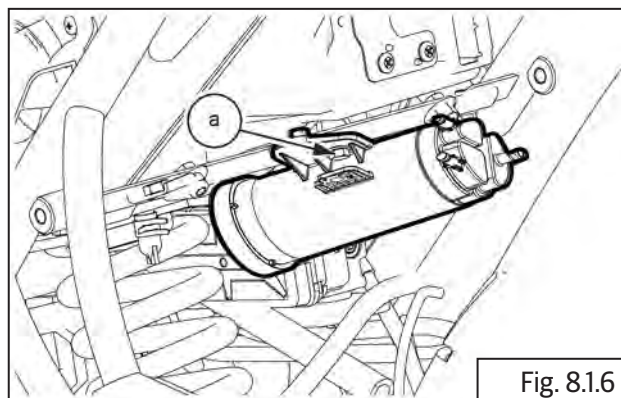

- Connect the drain hose, outlet hose and inlet hose (a) to the canister.

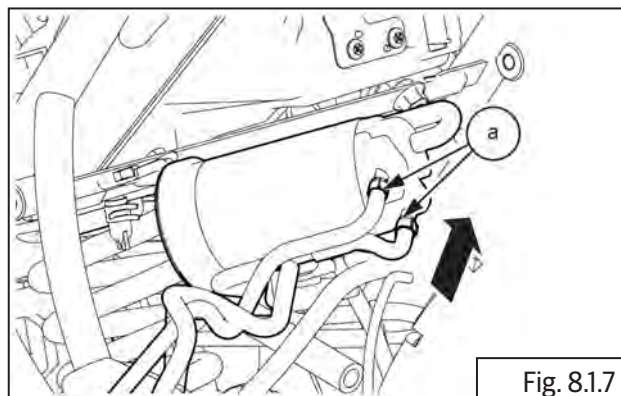

ELECTRICAL SYSTEM

3.1 Instrument Cluster Dismantling

- Remove the 2 Nos. Philip screw **(a)** from LH wind shield.

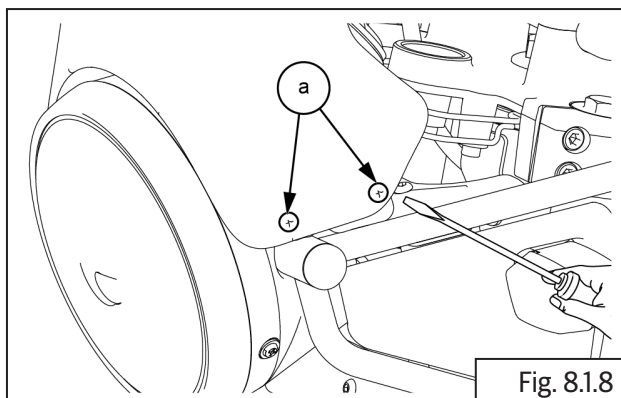

- Remove the 2 Nos. Philip screw **(a)** from RH wind shield.

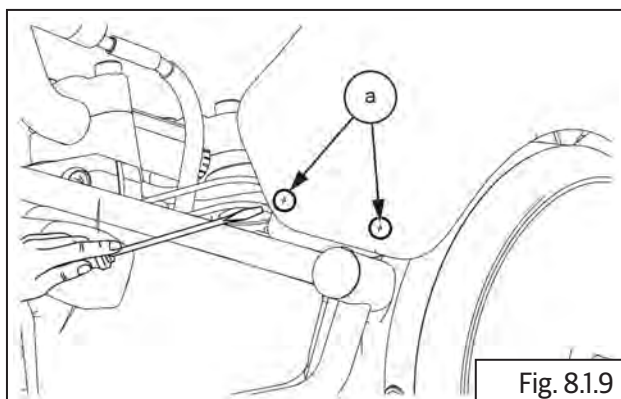

- Gently remove the wind shield **(a)**.

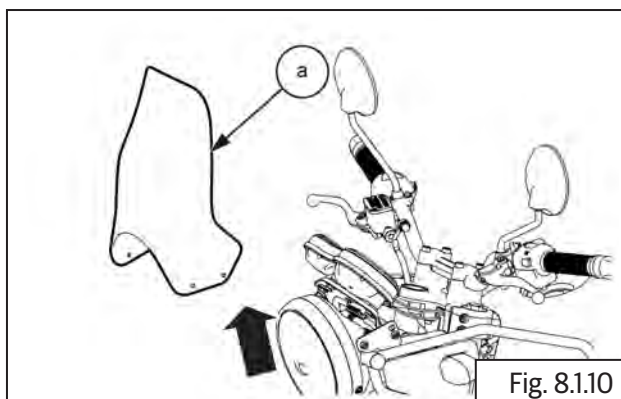

- Disconnect the instrument cluster connector **(a)**.

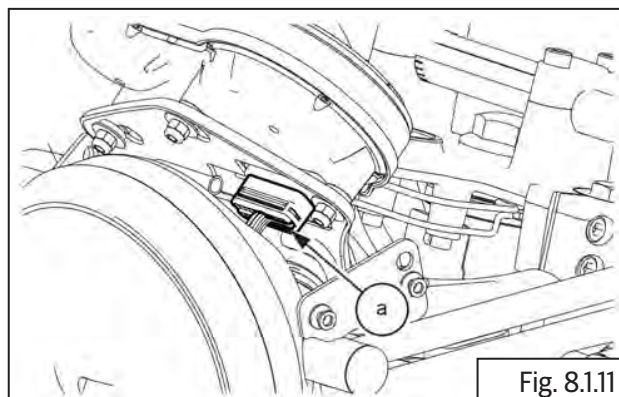

- Remove 3 Nos. Hex socket nut **(M6) (a)** located below Instrument cluster.

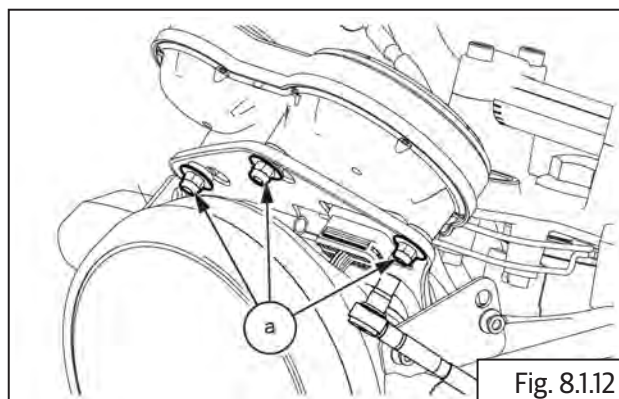

- Gently remove instrument cluster **(a)**.

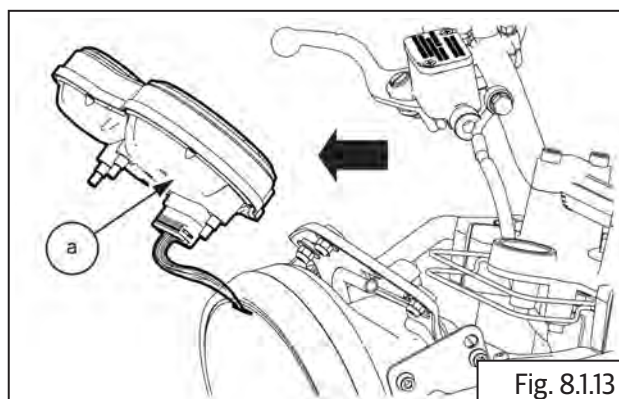

- Disconnect the navigation unit connector **(a)**.

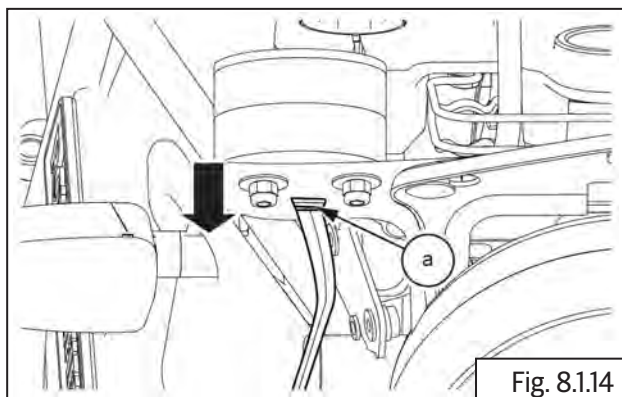

Fig. 8.114

- Remove 2 Nos. Hex socket head bolts **(M6) (a)** located below cluster bracket on RH.

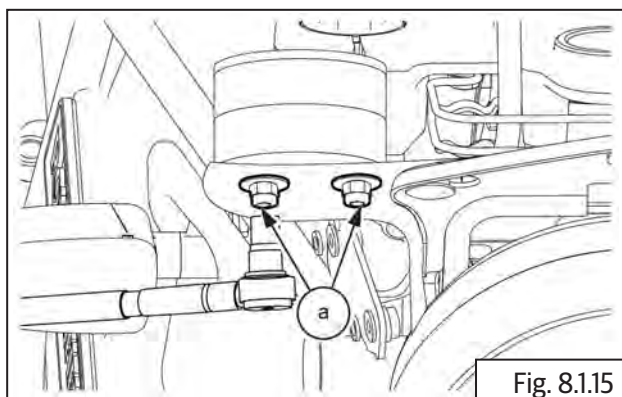

Fig. 8.115



5 mm Allen socket with Ratchet

- Gently remove navigation unit **(a)**.

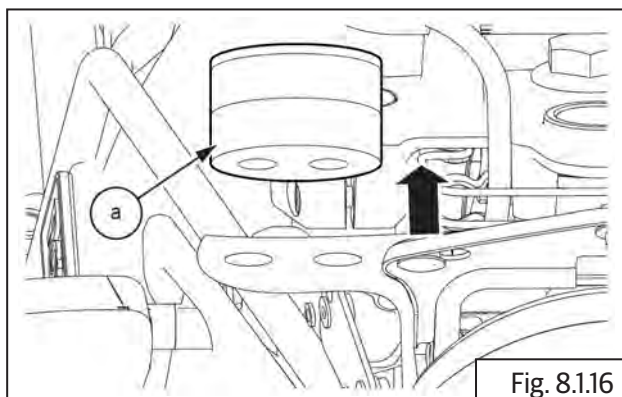

Fig. 8.116

3.2 Cluster Assembly

- Install the navigation unit using 2 Nos. Hex nut **(a)** on the bracket.

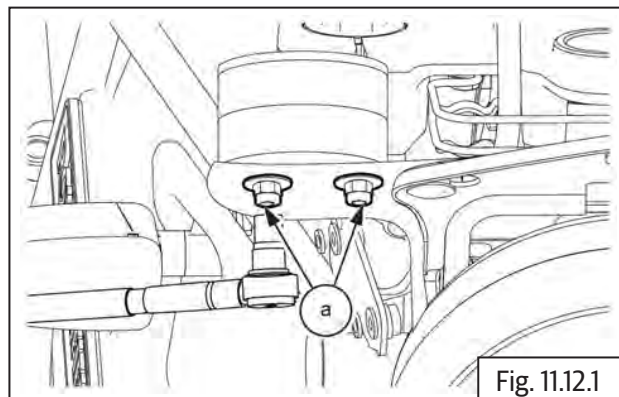

Fig. 11.12.1

- Connect the connector **(a)** to the navigation unit.

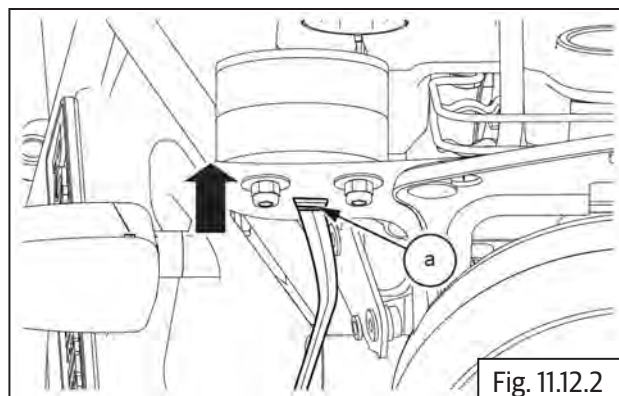

Fig. 11.12.2



5 mm Hex socket with Ratchet

Torque

10 N-m/1.01 kgf-m

- Align the instrument cluster **(a)** over the cluster bracket..

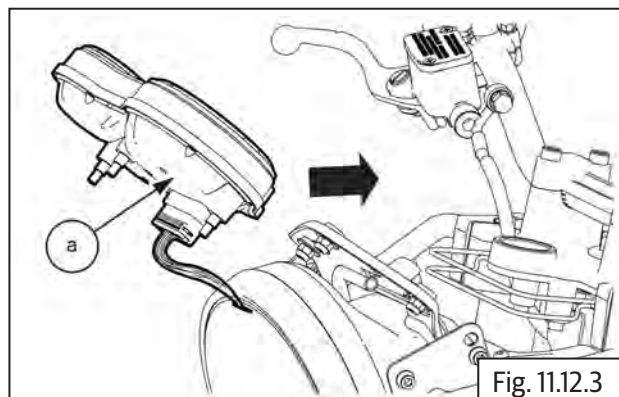

Fig. 11.12.3

- Install instrument cluster using 3 Nos. Hex nut **(a)**.

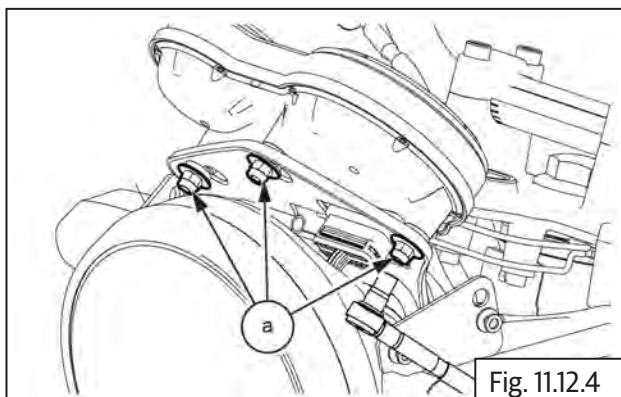



Fig. 11.12.4

	5 mm Hex socket with Ratchet
Torque	10 N-m/1.01 kgf-m

- Connect the instrument cluster connector **(a)**.

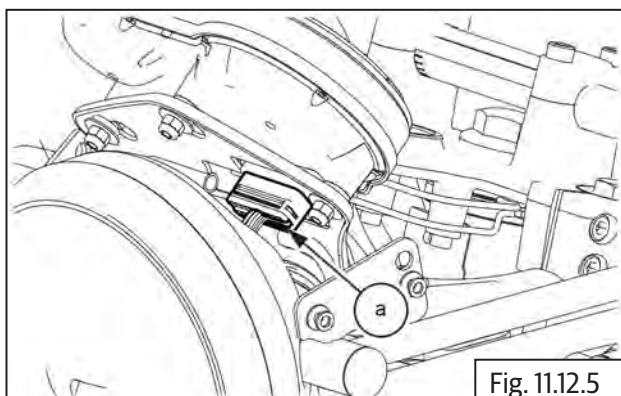

Fig. 11.12.5